

Please read and save this Repair Parts Manual. Read this manual and the General Operating Instructions carefully before attempting to assemble, install, operate or maintain the product described. Protect yourself and others by observing all safety information. The Safety Instructions are contained in the General Operating Instructions. Failure to comply with the safety instructions accompanying this product could result in personal injury and/or property damage! Retain instructions for future reference. AMT reserves the right to discontinue any model or change specifications at any time without incurring any obligation. ©2006 American Machine & Tool Co., Inc. of PA, A Subsidiary of The Gorman-Rupp Company, All Rights Reserved.

▲WARNING

Periodic maintenance and inspection is required on all pumps to insure proper operation. Unit must be clear of debris and sediment. Inspect for leaks and loose bolts. Failure to do so voids warranty.

Centrifugal Pumps

Refer to form 1808-634-00 for General Operating and Safety Instructions.

Description

These non self-priming centrifugal pumps are intended for liquid transfer, heating and cooling circulation, booster service and other industrial applications where no suction lift is required.

All models feature a semi-open clog-resistant impeller, and a pull-from-the-rear design for easy servicing. A dual volute casing is used on all models except 4240. A mechanical seal (comprised of carbon, ceramic and stainless steel components) isolates motor shaft from liquid being pumped. Discharge port on pump casing can be rotated in 90° increments with vent and drain plugs for all positions. Buna seals handle liquids from 40° to 180° F (4° to 82° C). Viton seals handle liquids from 40° to 200° F (4° to 90° C) Maximum ambient temperature 104° F (40° C). Casing working pressure to 100 psi (689 kPa). These are manual units, no controls are supplied. For use with nonflammable, non-abrasive liquids compatible with pump component materials.

Installation

Flooded Suction: Net Positive Suction Head Required (NPSHR). Curve with NPSHR available at www.amtpump.com.

- Problems will arise in operation of this pump unless the recommended NPSHR is supplied to the pump (See "Troubleshooting" chart in 1808-634-00 manual).
- Salt Water Usage:**
Because of crystallization and erosive material on the shaft seal (Ref. Nos. 9, 10), we recommend installation of seal-wash hose (Ref. No. 21). Using a wrench, remove the pipe plug (Ref. No. 20) from adapter (Ref. No. 18) and pipe plug (Ref. No. 15) from casing (Ref. No. 14) (remove pipe plug on the 3 o'clock position). Install optional seal wash hose.
NOTE: May require ordering casing cover (Ref. #18) with optional seal wash plug.

Maintenance

Make certain that unit is disconnected from power source before attempting to service or remove any component.

▲WARNING

remove any component.

REMOVAL OF OLD SEAL

Refer to Figure 1 for seal location.

IMPORTANT: Always replace both seal seat (Ref. No. 9) and seal head (Ref. No. 10) to insure proper mating of components! Also, impeller seal (Ref. No. 16) (where applicable) should be replaced any time impeller fastener (Ref. No. 13) has been removed.

- Remove fasteners (Ref. No. 6) that connect adapter (Ref. No. 3) to casing (Ref. No. 14).
- Remove casing and O-ring (Ref. No. 8).

▲CAUTION

Care should be taken not to pinch or "shave" o-ring between adapter and casing.

- Using a wrench remove impeller fastener, impeller seal (where applicable) and impeller (Ref. No. 12).

IMPORTANT: Care should be taken to insure that the same number of shim washers (Ref. No. 11) are replaced behind impeller as were removed. These shim washers are located directly behind impeller. These washers as well as impeller key (Ref. No. 19) (where applicable) become loose as impeller is removed.

- Seal head and shaft sleeve (Ref. No. 17) (where applicable) can now be pulled from shaft.
- Pry seal seat from adapter.
- Push seal head from shaft sleeve (where applicable).

INSTALLATION OF NEW SEAL

▲CAUTION **The precision lapped faces on shaft seal are easily damaged. Handle your replacement seal carefully.**

- Thoroughly clean all surfaces of seal seat cavity.
- Using a clean cloth, wipe shaft and shaft sleeve (where applicable) and make certain that they are perfectly clean.
- Wet rubber portion of new seal seat with a light coating of soapy water. While wearing clean gloves or using a clean light rag, press seal seat squarely into adapter recess. Avoid scratching white ceramic surface. If seat will not position properly, place a cardboard washer over polished surface and use a piece of pipe to press in firmly, but gently.
- Dispose of cardboard washer. Check again to see that polished surface is free of dirt and all other foreign particles and that it has not been scratched or damaged.

- Wet inside rubber portion of new seal head with a light coating of soapy water. Slide head onto shaft/shaft sleeve. Slide shaft sleeve with seal head onto motor shaft (where applicable). Seal head and seal seat will meet. Reinstall any shims which have been removed (See "Shim Adjustment" section).
- Replace impeller key (where applicable) and impeller. Replace impeller seal (where applicable) before screwing impeller fastener in place.
- Reassemble pump.
- A short "run-in" period may be necessary to provide completely leak free seal operation.

SHIM ADJUSTMENT

When installing a replacement impeller (Ref. No. 12) or motor (Ref. No. 1), it may be necessary to adjust the number of shims (Ref. No. 11) to insure proper running clearance between impeller and casing (Ref. No. 14). Proceed as follows:

NOTE: A proper running clearance is less than 0.010".

- For impeller replacement, add one 0.010" shim in addition to those removed originally.
- For motor replacement, add two 0.010" shims in addition to shims removed during disassembly.
- Reassemble pump as described in steps 6 and 7. (See "Installation of New Seal" section).

IMPORTANT: Insure that casing is snugly in place and check shaft to make sure it is turning freely (rotate impeller by impeller fastener, Ref. No. 13 with a wrench). If it turns freely, check to insure that adapter (Ref. No. 3) and casing are fitted metal-to-metal where they meet on outside. If they are not metal-to-metal, tighten fasteners (Ref. No. 6) and recheck shaft for free turning. Tighten carefully, turning shaft while tightening so that motor bearings are not damaged in the event that too many shims were installed. If shaft seizes before fasteners are completely tight, disassemble pump and remove one shim and repeat reassembly.

For Repair Parts, contact dealer where pump was purchased.

Please provide the following information: Model number, Serial number (if any), Part description and number as shown in parts list.

Repair Parts List

Ref. No.	Description	Part No. for Models:					Qty.
		56J Frame		145JM	182JM	184JM	
		3158	315C	Frame	Frame	Frame	
		3159	315D			315E	
	3156	315A		3151	3152		
	3157	315B	3150	3154	3155		
	2 HP	3 HP	2 HP	3 HP	5 HP		
1	Motor - 1 Phase ODP	◆ 1626-024-00	1626-026-00	-	◆ -	-	1
	Motor - 3 Phase ODP	◆ 1626-025-00	1626-027-00	-	◆ -	-	
	Motor - 1 Phase TEFC	◆ 1626-070-00	1626-071-00	-	◆ -	1626-078-00	
	Motor - 3 Phase TEFC	◆ 1626-054-00	1626-072-00	1626-042-00	◆ 1626-043-00	1626-044-00	
2	Slinger Washer	1534-000-00	1534-000-00	1470-093-00	1470-093-00	1470-093-00	1
3	Adapter - Cast Iron Models	4890-030-01	4890-030-01	N/A	1470-001-02	1470-001-02	1
	Adapter - Bronze Models	4890-032-01	4890-032-01	3150-033-09	3150-033-09	3150-033-09	1
	Adapter - SS Models	-	4890-031-01	3150-033-09	3150-033-09	3150-033-09	1
4	Washer	*	*	*	*	*	4
5	Fastener	*	*	*	*	*	4
6	Fastener	*	*	*	*	*	4
7	Washer	*	*	*	*	*	4
8	O-ring -Buna N (cast iron)	‡	‡	‡	‡	‡	1
	Viton - Bronze and SS	‡	‡	‡	‡	‡	1
9,10	‡ Shaft seal assembly - See ‡ below		1640-161-96	1640-163-90	1640-163-90	1640-163-90	1
	Impeller shim set includes (1) 0.030", (1) 0.020", (1) 0.010"						
11		1806-044-90	1806-044-90	1664-000-90	1664-000-90	1664-000-90	1
12	Impeller	3156-010-01	3156-010-02	3150-013-09	3151-013-09	3152-013-09	1
13	Impeller fastener	1784-001-00	1784-001-00	1757-010-00	1757-010-00	1757-010-00	1
14	Casing - Cast Iron (NPT)	1470-000-01	1470-000-01	1470-000-01	1470-000-01	1470-000-01	1
	Casing - Cast Iron (Flanged)	-	-	-	1469-000-01	1469-000-01	1
	Casing - Bronze, (NPT)	1470-005-09	1470-005-09	1470-005-09	1470-005-09	1470-005-09	1
	Casing - SS (NPT)	3150-003-09	3150-003-09	3150-003-09	3150-003-09	3150-003-09	1
15	Pipe Plug	*	*	*	*	*	4
16	O-Ring	‡	‡	‡	‡	‡	1
17	Shaft sleeve	-	-	1472-000-00	1472-000-00	1472-000-00	1
18	Casing cover - Cast Iron Models	-	-	3150-025-09	3150-025-09	3150-025-09	1
	Casing cover - Bronze Models	-	-	3150-024-09	3150-024-09	3150-024-09	1
	Casing cover - Stainless Steel Models	-	-	3150-023-09	3150-023-09	3150-023-09	1
19	Impeller key	-	-	1471-030-00	1471-030-00	1471-030-00	1
20	Pipe Plug (optional for seal wash)	*	*	*	*	*	1
21	Hose (optional for seal wash)	4261-170-00	4261-170-00	4261-170-00	4261-170-00	4261-170-00	1
	‡ Seal Kit - Buna N (standard) cast iron	3156-300-94	3156-300-94	3150-300-94	3150-300-94	3150-300-94	1
	‡ Seal Kit - Buna N & Sil. Carb. (optional)	3156-300-93	3156-300-93	3150-300-93	3150-300-93	3150-300-93	1
	‡ Seal Kit - Viton (standard) Bronze & SS	3156-300-91	3156-300-91	3150-300-91	3150-300-91	3150-300-91	1
	‡ Seal Kit - Viton & Sil. Carb. (optional)	3156-300-92	3156-300-92	3150-300-92	3150-300-92	3150-300-92	1

(*) Standard hardware item, available locally;

‡ Seal kits include Ref. Nos. 8, 9, 10, 16

For Repair Parts, contact dealer where pump was purchased.

Please provide the following information: Model number, Serial number (if any), Part description and number as shown in parts list.

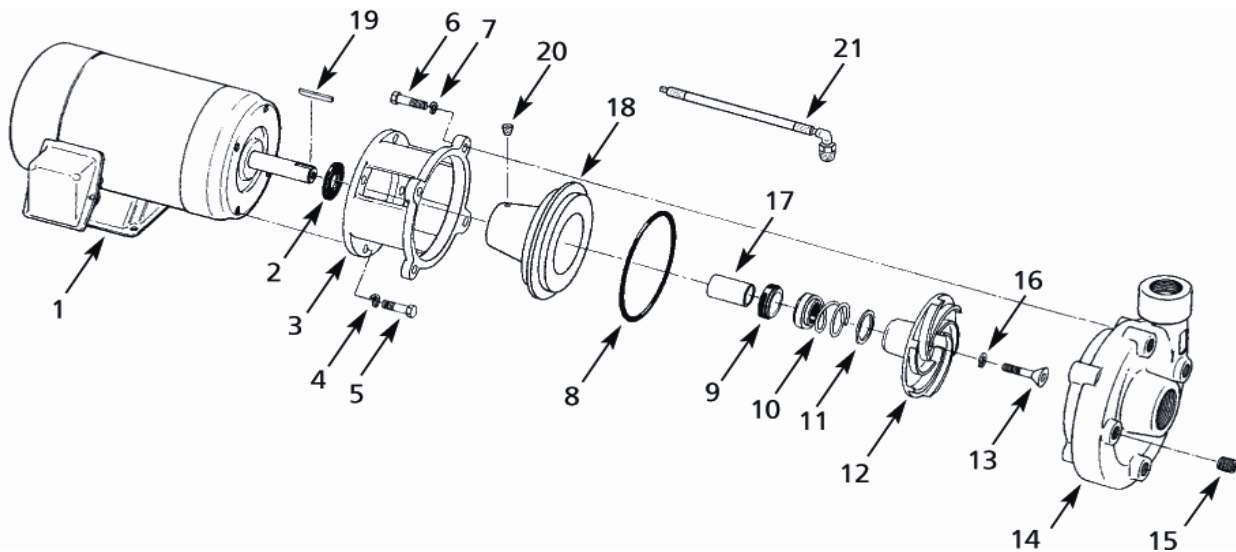

Figure 1 - Repair Parts Illustration
Repair Parts List

Ref. No.	Description	Part No. for Models:					Qty.
		184 JM Frame 4260 7.5 HP	4240 7.5 HP	4261 10 HP	215 JM Frame 4250 10 HP	4251 15 HP	
1	Motor	1626-045-00	1626-045-00	1626-081-00	1626-081-00	1626-047-00	1
2	Slinger washer	1470-093-00	1470-093-00	1470-093-00	1470-093-00	1470-093-00	1
3	Adapter	3150-033-09	4252-033-01	3150-033-09	4252-033-01	4252-033-01	1
4	Washer	*	*	*	*	*	4
5	Fastener	*	*	*	*	*	4
6	Fastener	*	*	*	*	*	4
7	Washer	*	*	*	*	*	4
8	O-ring	‡	‡	‡	‡	‡	1
9,10 ‡	Shaft seal assembly - See ‡ below	‡	‡	‡	‡	‡	1
11	Impeller shim set includes (1) 0.030", (1) 0.020", (1) 0.010"	1664-000-90	1664-000-90	1664-000-90	1664-000-90	1664-000-90	1
12	Impeller	4260-013-01	4240-013-01	4261-013-01	4250-013-01	4251-013-01	1
13	Impeller fastener	1761-002-00	1759-003-00	1761-002-00	1759-003-00	1757-005-00	1
14	Casing - Cast iron	2217-001-01	4240-001-09	2217-001-01	4250-001-09	4250-001-09	1
	Casing - Bronze	2217-002-09	4240-004-01	2217-002-09	4250-004-01	4250-004-01	1
	Casing - Stainless Steel	4260-003-01	4240-003-01	4260-003-01	4250-003-01	4250-003-01	1
15	Pipe plug	*	*	*	*	*	4
16	O-ring - Buna-N	‡	‡	‡	‡	‡	1
17	Shaft sleeve	1472-000-00	1472-000-00	1472-000-00	1472-000-00	1472-000-00	1
18	Casing cover - Cast iron	3150-025-09	4240-025-01	3150-025-09	4240-025-01	4240-025-01	1
	Casing cover - Bronze	3150-024-09	4240-024-01	3150-024-09	4240-024-01	4240-024-01	1
	Casing cover - Stainless Steel	3150-023-09	4240-023-01	3150-023-09	4240-023-01	4240-023-01	1
19	Impeller key	1471-030-00	1471-030-00	1741-030-00	1471-030-00	1471-030-00	1
20	Pipe Plug (Optional for seal wash)	*	*	*	*	*	1
21	Hose (optional for seal wash)	4261-170-00	4261-170-00	4261-170-00	4261-170-00	4261-170-00	1
‡	Seal Kit - Buna N (standard) cast iron	3150-300-94	4240-300-94	3150-300-94	4240-300-94	4240-300-94	1
‡	Seal Kit - Buna N & Sil. Carb. (optional)	3150-300-93	4240-300-93	3150-300-93	4240-300-93	4240-300-93	1
‡	Seal Kit - Viton (standard) Bronze & SS	3150-300-91	4240-300-91	3150-300-91	4240-300-91	4240-300-91	1
‡	Seal Kit - Viton & Sil. Carb. (optonal)	3150-300-92	4240-300-62	3150-300-92	4240-300-92	4240-300-92	1

(*) Standard hardware item, available locally;

‡ Seal Kit includes Ref. Nos. 8, 9, 10, 16