

ABS SUBMERSIBLE DRAINAGE PUMP JC 6

US 60 Hz

Specification

Electric submersible pump with double outer casing.
Class B insulation.
Maximum submergence: 26 feet.

JC 6 W Medium head, single-phase.

Electric Motor

Single-phase motor with built-in capacitor, 60Hz.
Motor rating P_2 : 0.6 Hp
Speed: 3450 rpm

Voltage, V	115
Nominal current, A	5.4

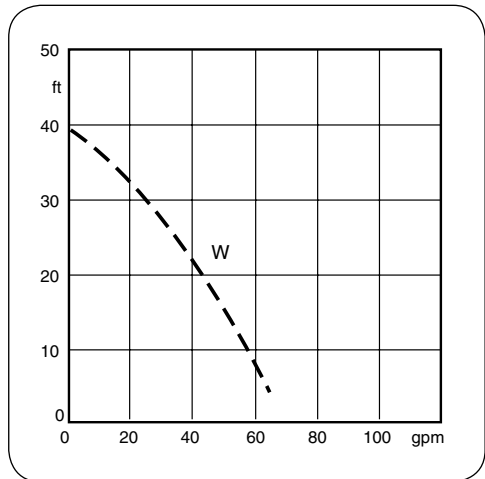

Power Cable

Heavy duty power cable for submersible pump applications
32 ft AWG 16/3 SOW-A (UL, CSA, MSHA)

Motor Protection

Built-in thermal motor protector.

Shaft Seal

Double mechanical seal in oil bath with oil circulator.
Primary seal: Silicon carbide on silicon carbide.
Secondary seal: Silicon carbide on silicon carbide.

Bearings

Single-row deep groove ball bearing.

Discharge Connections

2" NPT threaded connections.

Weight (without cable)

30 lb

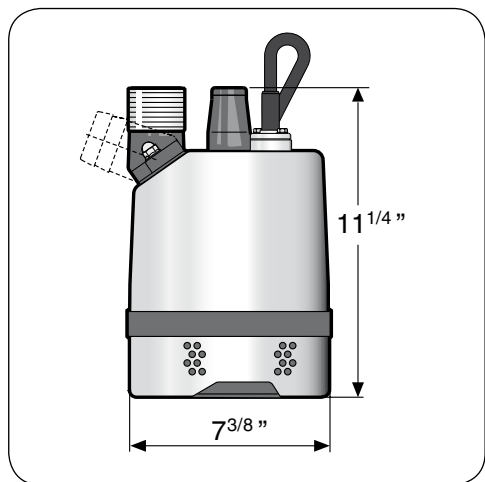

Materials

Castings	Aluminium
Casing	Stainless steel
Shaft	Stainless steel
Impeller	Polyurethane
Wear parts	Ethylene propylene rubber/ Polyurethane

