

Combination pH/ORP Sensor

1.0 FEATURES AND APPLICATIONS

The Rosemount Analytical Model 399 Sensor measures the pH or the Oxidation Reduction Potential (ORP) of aqueous solutions in pipelines, open tanks, or ponds. It is suitable for virtually all applications where a low cost, disposable sensor is required. The combination electrode features a ceramic junction constructed in an annular design around the pH/ORP sensitive membrane. The double junction reference cell configuration is resistant to process solutions containing ammonia, chlorine, cyanides, sulfides, or other poisoning ions.

The glass electrode is housed in a molded Tefzel^{®1} body and sealed with Viton^{®1} O-rings to guard against process leakage. The cable end of the sensor is also sealed, eliminating cable shorts caused by exposure to moisture. This construction makes for a highly chemical resistant disposable sensor and does not require electrolyte replenishment.

The custom glass electrode is available with either a standard hemi bulb or an optional flat bulb to best meet your application needs. Flat glass is advantageous in abrasive or coating applications that etch or build up on the glass respectively. In coating applications, such as slurries, the flat surface allows the process flow to act as a scrubbing agent to reduce coating and maintenance whereas in abrasive applications pitting from silicates and other similar materials is minimized by the flat surface to provide longer life. The hemi bulb is ideal for general purpose use and for those processes requiring greater accuracy over the entire pH range.

The Rosemount Analytical pH/ORP sensor offers an optional integral preamplifier to convert the high impedance pH or ORP mV signal into a stable, noise-free signal with transmission capability of up to three miles. The Rosemount Analytical preamp method has become the industry standard for pH/ORP measurement reliability.

Installation is easily achieved through the wide variety of mounting configurations. The Model 399 features 1 in. (MNPT) front and rear facing connections for insertion, submersion or flow through pH and ORP applications.



2.0 PHYSICAL SPECIFICATIONS

Materials of Construction: Tefzel^{®1}, glass, ceramic and Viton^{®1} (also, Platinum for ORP sensor)

Process Connections: 1 in. MNPT

Interconnecting Cable: 5 conductor, 10 or 32 ft cable undressed (integral preamp)
10 ft coax cable (Code 02, 09)
10 ft shielded coax cable (Code 04)
4 conductor, 20 or 100 ft cable undressed (Code 12, 13, 33)

Measured Range: pH: 0-14
ORP: -1500 -+1500mV
Percent Linearity over pH range:

	Hemi Bulb	Flat Bulb
1-2 pH	94%	93%
2-12 pH	99%	98%
12-13 pH	97%	95%

Temperature Compensation: Automatic 0 to 85°C (32° to 185°F) (Temperature compensation is not required for 399 ORP when used with Models 1060, 1023 or 1181 ORP)

Maximum Pressure: 790 kPa abs (100 psig) at 65°C (Refer to Graph A on page 4)

Weight/Shipping Weight: 0.45 kg/0.9 kg (1 lb/2 lb)

¹ Tefzel and Viton are registered trademarks of DuPont Performance Elastomers.

3.0 UNPACKING. The sensor is shipped in a container with special cushioning material. Before opening the container, it should be inspected for any damage. If any damage is detected, the carrier should be notified before proceeding further. Carefully remove the sensor from the container and packing material. Inspect the sensor for any visible damage. If no damage is found, carefully remove the rubber boot which protects the glass electrode and keeps the liquid junction wetted.

NOTE

If the sensor is to be stored, the rubber boot should be filled with pH buffer solution and replaced on sensor tip until ready to use.

4.0 SENSOR PREPARATION. Shake down the sensor to remove any air bubbles that may be present at the tip of the pH glass bulb.

WARNING

Glass electrode must be wetted at all times (in storage and in line) to maximize sensor life.

5.0 CALIBRATION USING A STANDARD BUFFER SOLUTION.

1. Make a temporary electrical connection between the sensor and instrument.
2. Consult the appropriate pH or ORP analyzer/transmitter instruction manual for the specific calibration and standardization procedure.
3. After successful completion of the calibration and standardization procedure, install the Model 399 sensors in the process (see Figures 2 through 9).

6.0 INSTALLATION. The sensor has been designed to be located in industrial process environments. Temperature and pressure limitations must not be exceeded at any time (see Graph A).

6.1 Flow Through Installations. The Model 399 Sensor has a 1 in. MNPT process connection at the front of the sensor for mounting directly into a 1-1/2 in. tee. See Figure 2 for installation configurations. It is recommended that shut-off valves be provided for sensor removal and service.

6.2 Insertion Installations. The Model 399 sensor has forward and rear facing 1 in. MNPT process connections for pipeline installations utilizing flange connections. The Model 399 is also suitable for side-of-tank installation. The Model 399 must be mounted 15°- 30° above horizontal (see Figure 3).

6.3 Submersion Mounting. The Model 399 Sensor has a 1 in. MNPT process connection at the back of the sensor (see Figures 4 and 5). Utilizing a standard 1 in. union, the sensor may be mounted to a 1 in. SCH 80 CPVC or PVDF standpipe. Tapered pipe threads in plastic tend to loosen after installation. It is therefore recommended that the tightness of the connection be checked frequently to assure that no loosening has occurred. To prevent rain water or condensation from running into the sensor, a weatherproof junction box is recommended (Rosemount Analytical PN 22719-02). The sensor cable must be run through a protective conduit for isolation from electrical interference or physical abuse from the process. The sensor should be installed within 80° of vertical, with the electrode facing down. The sensor's cable should not be run with power or control wiring.

NOTE

LARGE PIPE WRENCHES MUST NOT BE USED TO TIGHTEN THE SENSOR INTO A FLANGE OR OTHER TYPE OF MOUNTING.

7.0 WIRING. The Model 399 has an optional built-in preamplifier and comes standard with a shielded cable or coax cable. The cable should be handled carefully and kept dry and free of corrosive chemicals at all times. Extreme care should be used to prevent it from being twisted, damaged or scraped by rough, sharp edges or surfaces. The cable is supplied undressed. Please refer to Figures 10 through 28 or the applicable analyzer/transmitter instruction manual for electrical connections.

8.0 START-UP. After the sensor has been installed and the process solution is in contact with the sensor, the transmitter may need to be recalibrated. A grab sample method is recommend. Please refer to your analyzer/ transmitter's instruction manual for procedure.

The Model 399pH has an automatic temperature compensator. This compensates for changes in the output of the glass electrode with changes in temperature.

9.0 MAINTENANCE. The Model 399 Sensor is a throw-away type and therefore requires a minimum of maintenance. The sensor should be kept clean and free of debris and sediment at all times. The frequency of cleaning by wiping or brushing with a soft cloth or brush is determined by the nature of the solution being measured. The sensor should be removed from the process periodically and checked in buffer solutions as outlined in Section 5.0. If the sensor will not calibrate, refer to your analyzer/ transmitter instruction manual for proper test procedures. If it is determined that the sensor has failed, it should be discarded and replaced.

FIGURE 1. MOUNTING AND DIMENSIONAL DRAWINGS

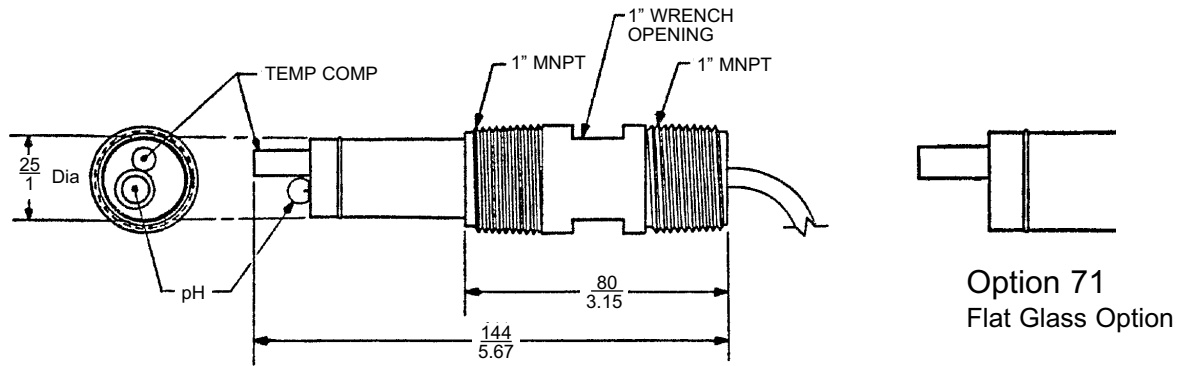

FIGURE 2. FLOW THROUGH INSTALLATIONS

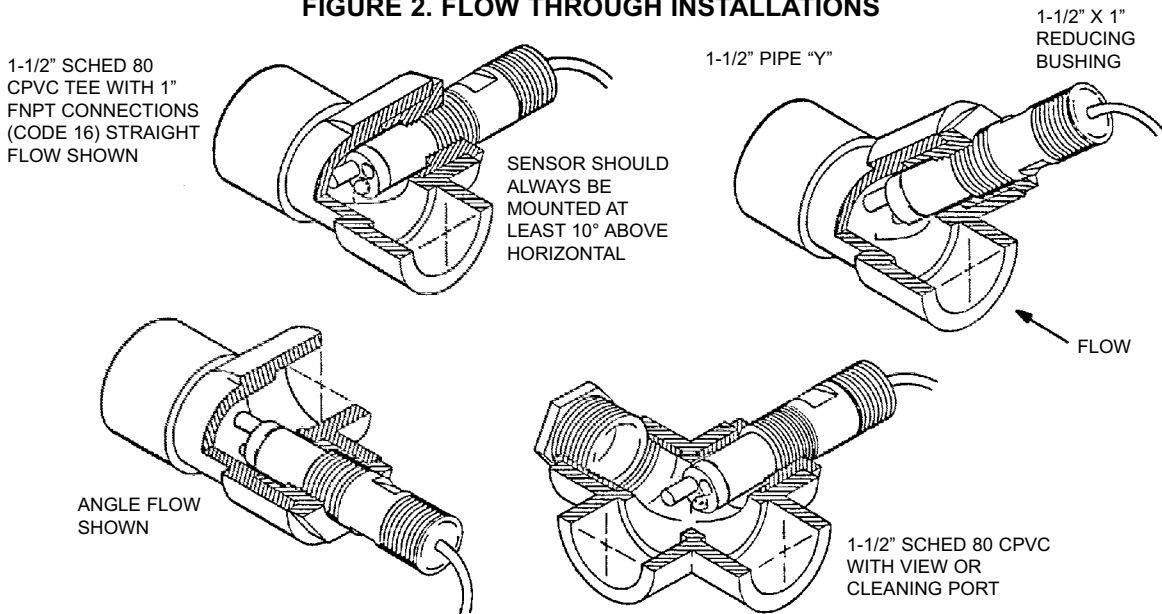

FIGURE 3. INSERTION INSTALLATIONS

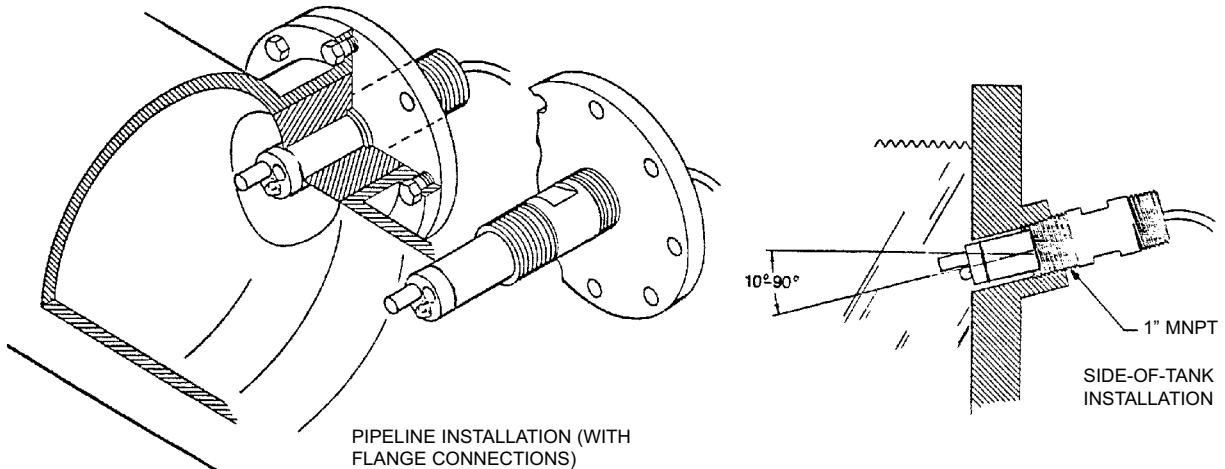
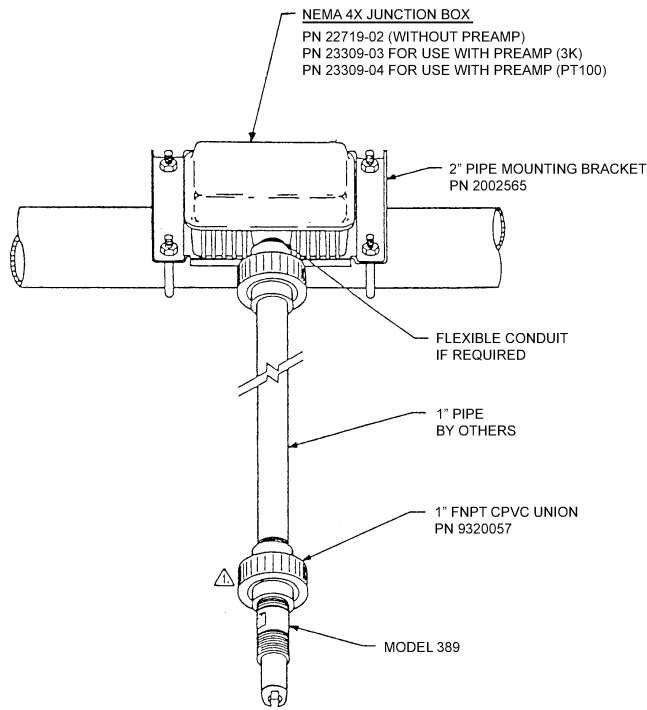
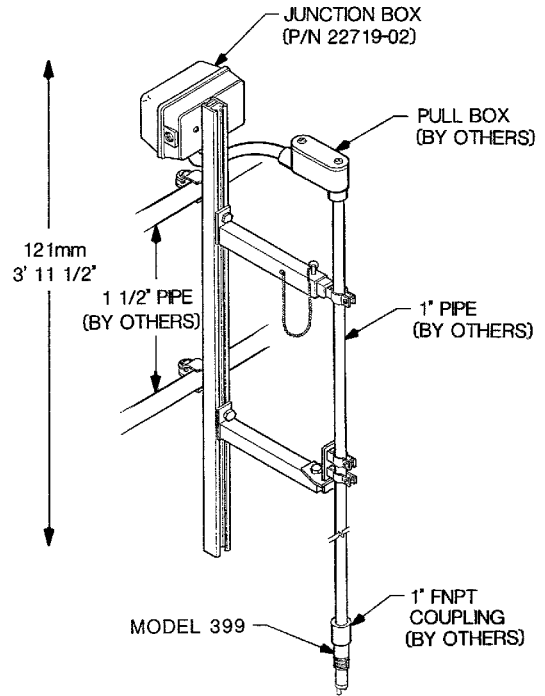

FIGURE 4. - SUBMERSION INSTALLATIONS



Submersion Installation Using a Remote Junction Box, Mounting Bracket, and Pipe Mount Union Accessory

Pipe supplied by customer and can be any length.



Submersion Installation Using the Handrail Mounting Kit (PN 1000857)

Pull box, pipe, and coupling supplied by customer. Junction box is sold separately.

**GRAPH A
PRESSURE/TEMPERATURE LIMITATIONS FOR MODEL 399***

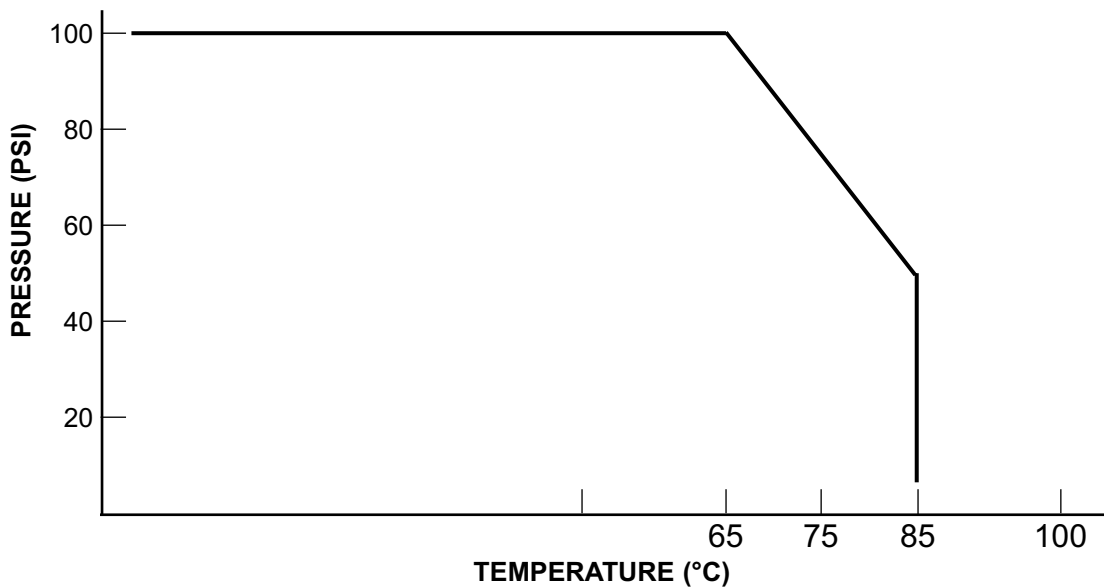

*Please consult factory for specification, pricing and delivery information of Model 399, less integral preamp.

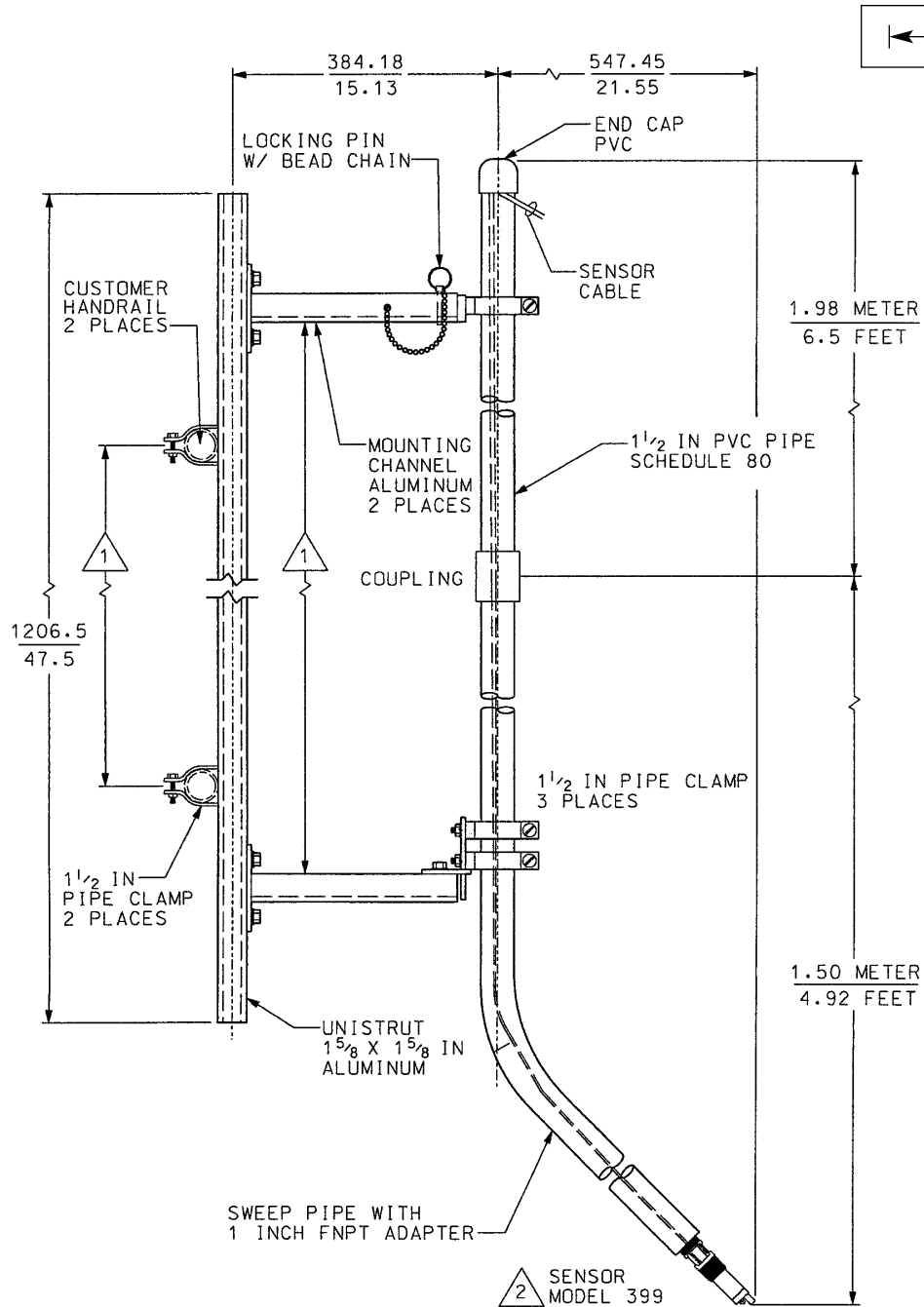

- △ 2 REGULARY CHECK TO MAKE SURE CONNECTIONS ARE WATER TIGHT
- △ 1 CAN BE ANY CONVENIENT DIMENSION

FIGURE 5. Submersion Installation Using the Handrail Mounting Assembly (PN 11275-01)

All parts shown are supplied; sensor is sold separately.

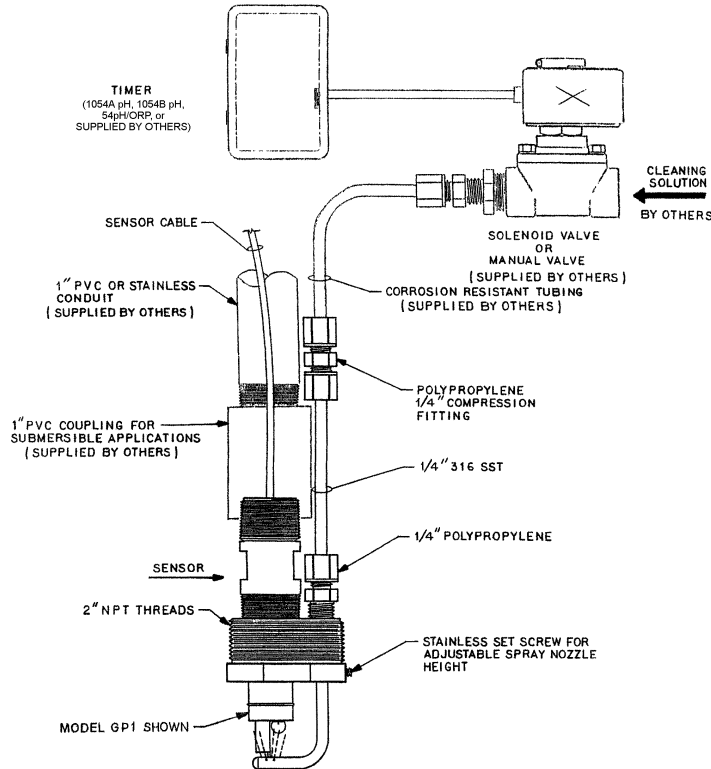

FIGURE 6. Jet Spray Cleaner (PN 12707-00) for Submersion Installations

This accessory is especially useful for keeping the sensor clean in dirty ponds or tanks. It can be mounted using the Handrail Mounting Assembly or a similar submersion accessory.

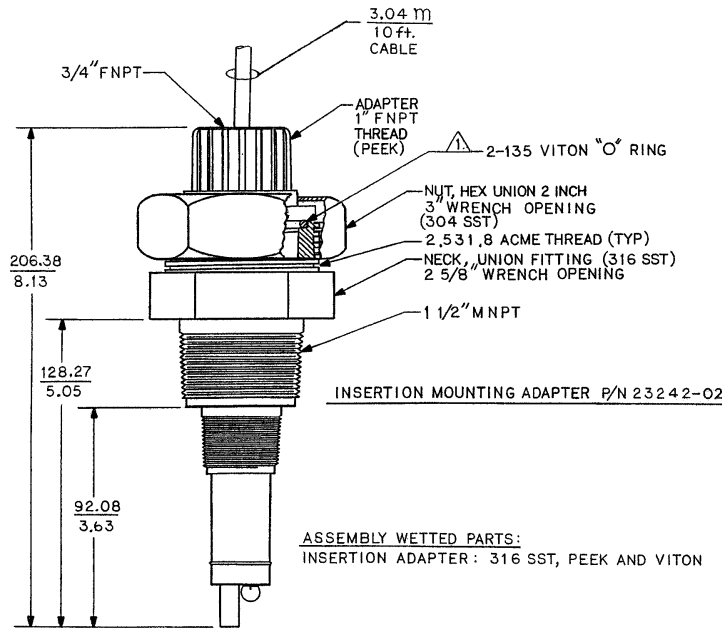

FIGURE 7. Sensor With Insertion Adapter (PN 23242-02)

This accessory fits the sensor into 1-1/2 inch threaded pipe tees. The sensor can be removed easily and without twisting the sensor cable.

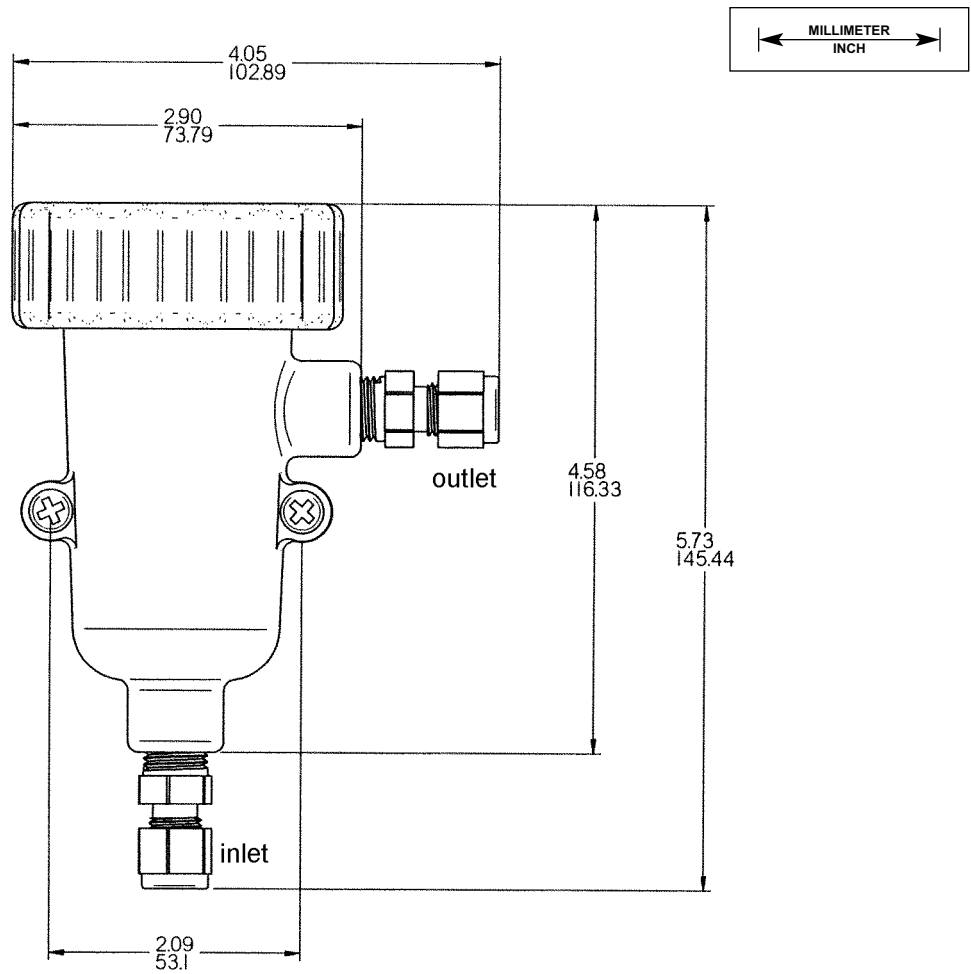

FIGURE 8. Sensor Shown in Low Flow Cell Assembly (PN 24091-00)

Ideal for tapping into existing pipe lines or for minimal process flow requirements.

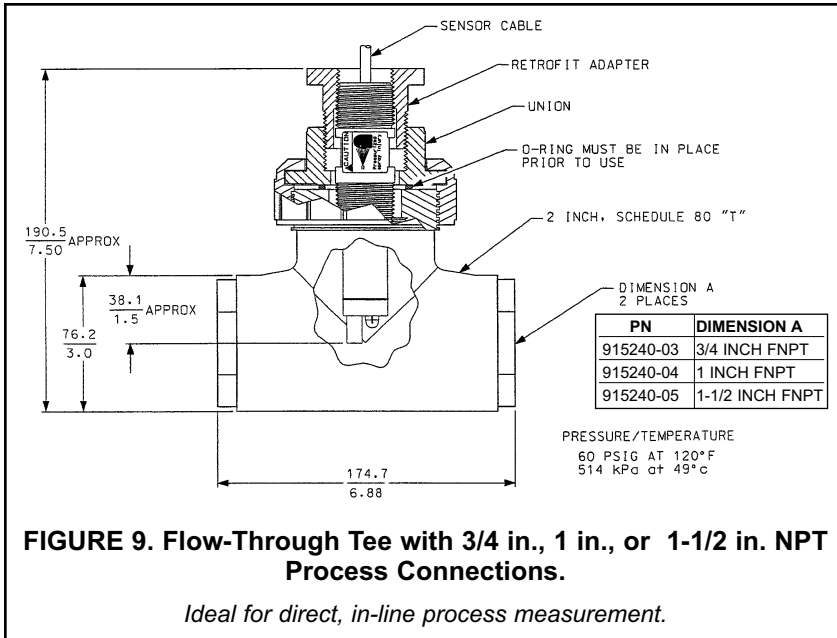

FIGURE 9. Flow-Through Tee with 3/4 in., 1 in., or 1-1/2 in. NPT Process Connections.

Ideal for direct, in-line process measurement.

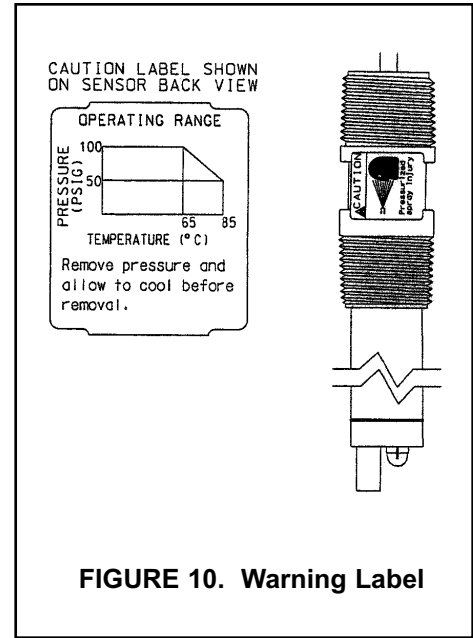

FIGURE 10. Warning Label

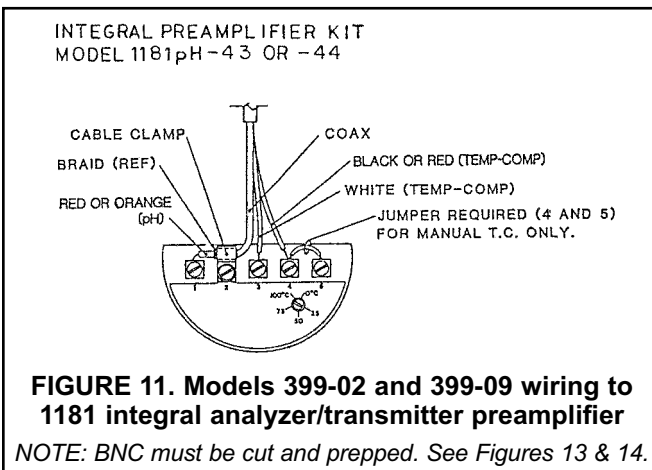

FIGURE 11. Models 399-02 and 399-09 wiring to 1181 integral analyzer/transmitter preamplifier

NOTE: BNC must be cut and prepped. See Figures 13 & 14.

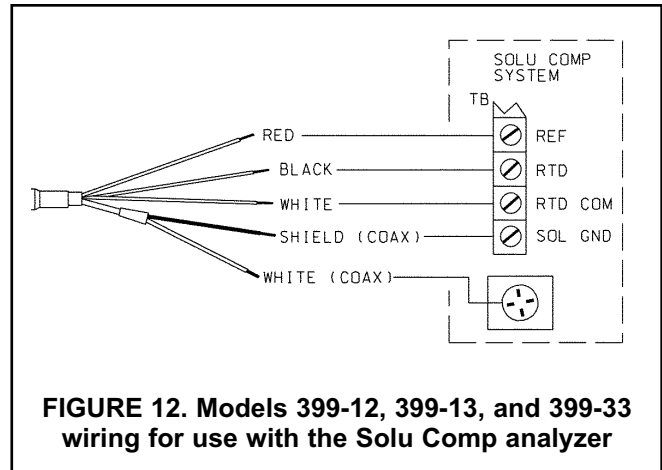

FIGURE 12. Models 399-12, 399-13, and 399-33 wiring for use with the Solu Comp analyzer

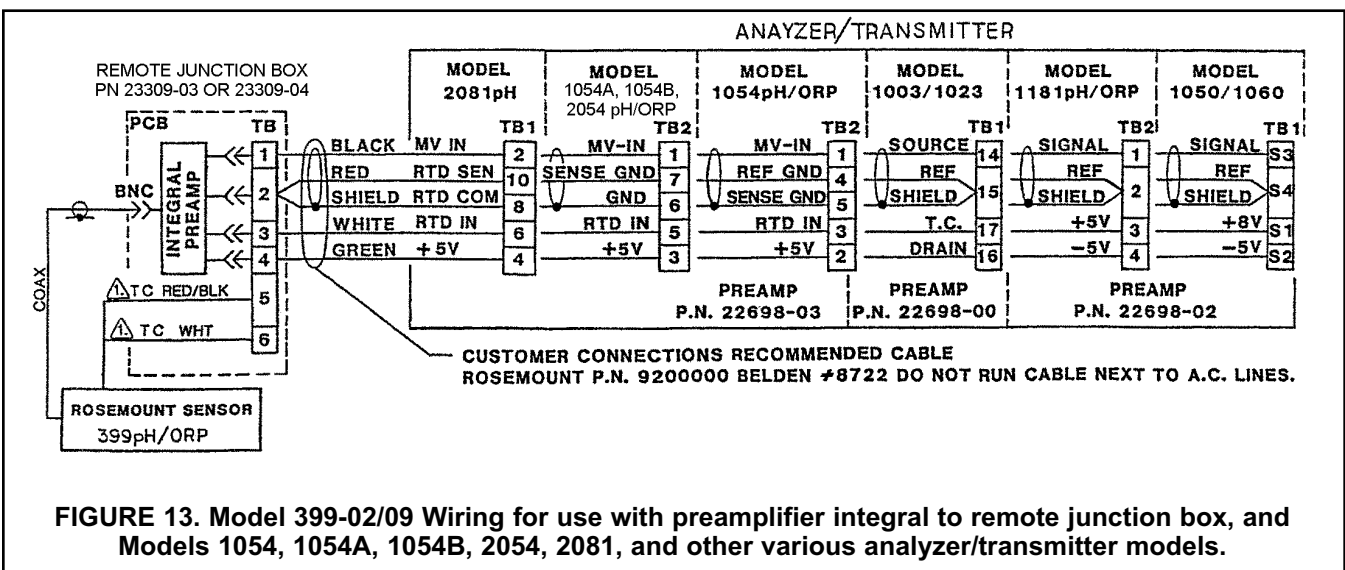
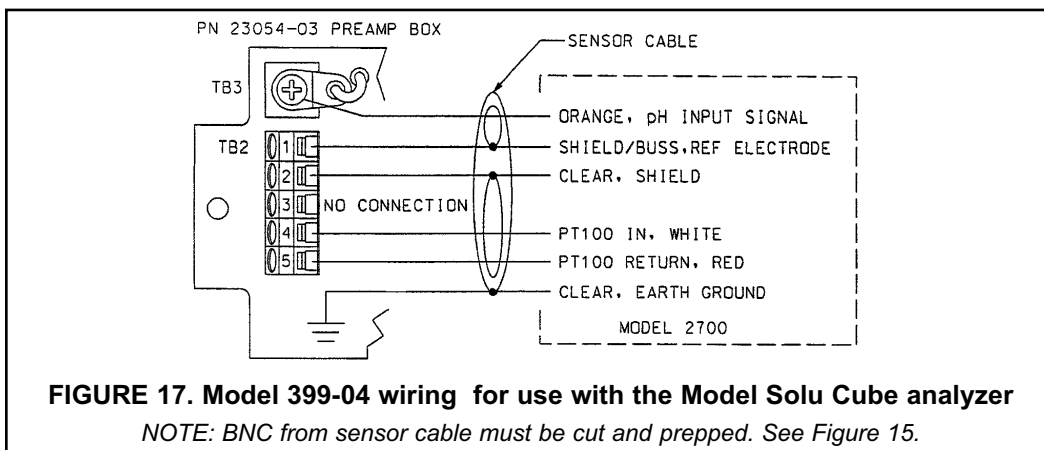
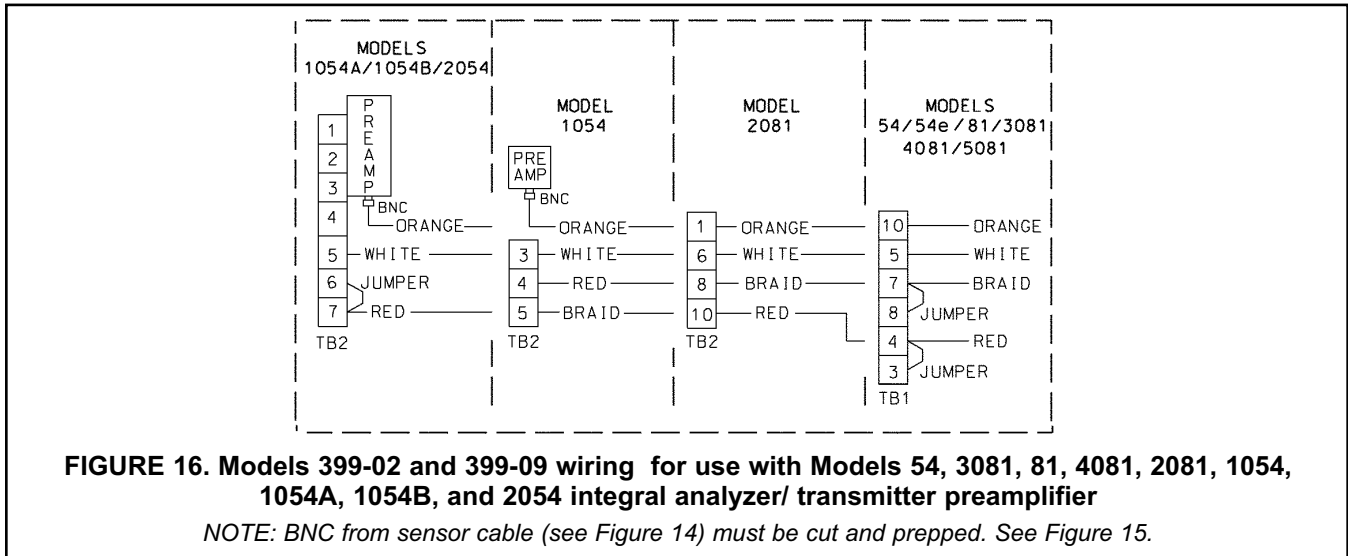
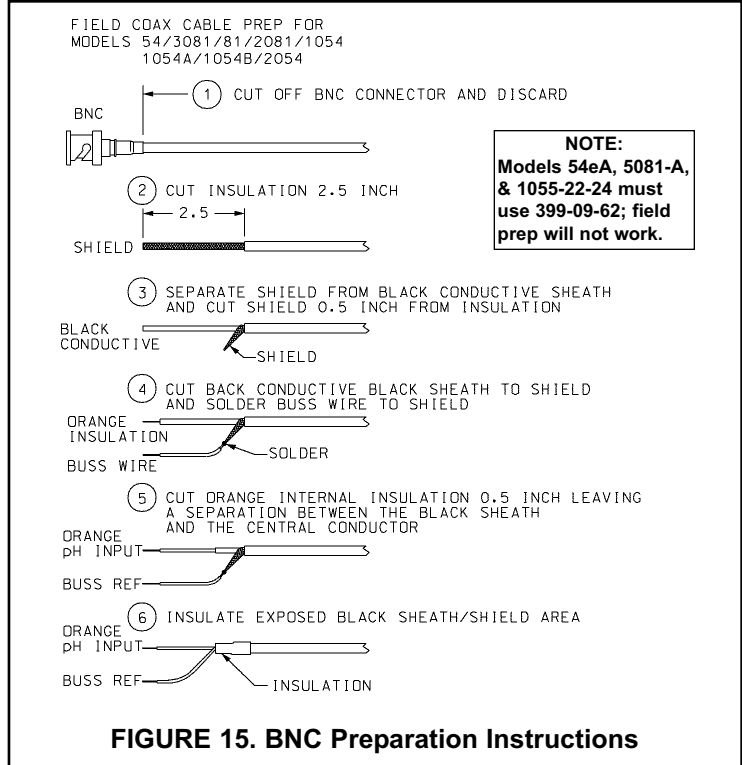
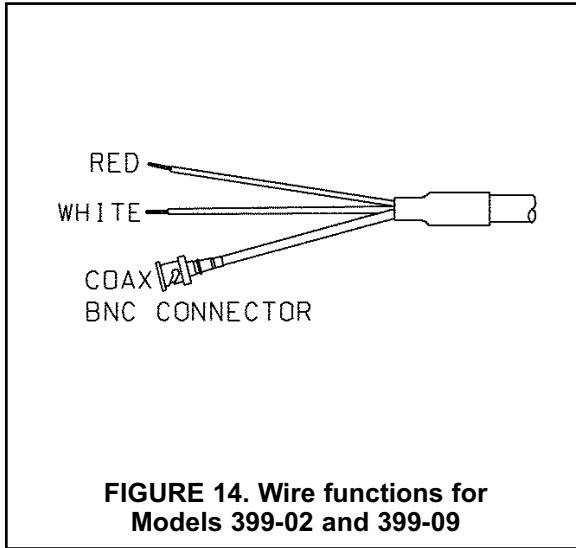

FIGURE 13. Model 399-02/09 Wiring for use with preamplifier integral to remote junction box, and Models 1054, 1054A, 1054B, 2054, 2081, and other various analyzer/transmitter models.



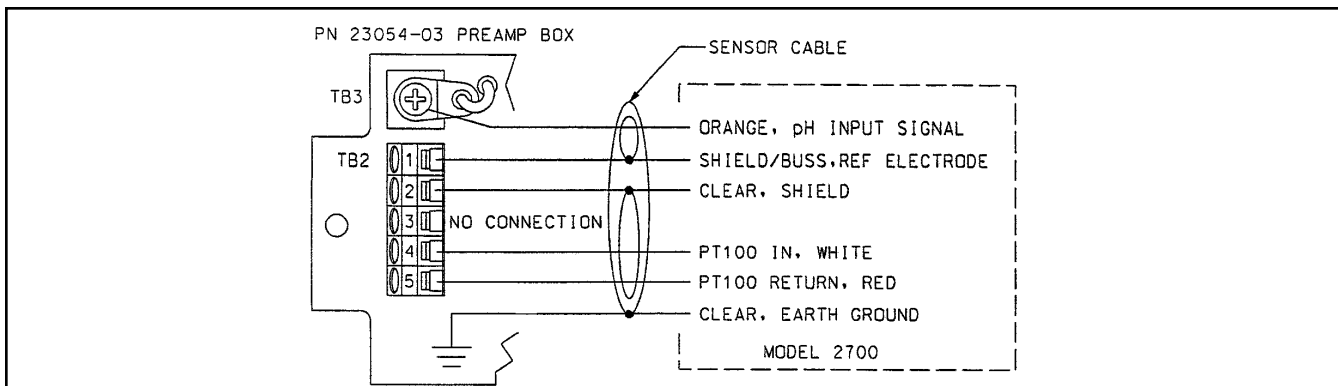

FIGURE 17. Model 399-04 wiring for use with the Model Solu Cube analyzer

NOTE: BNC from sensor cable must be cut and prepped. See Figure 15.

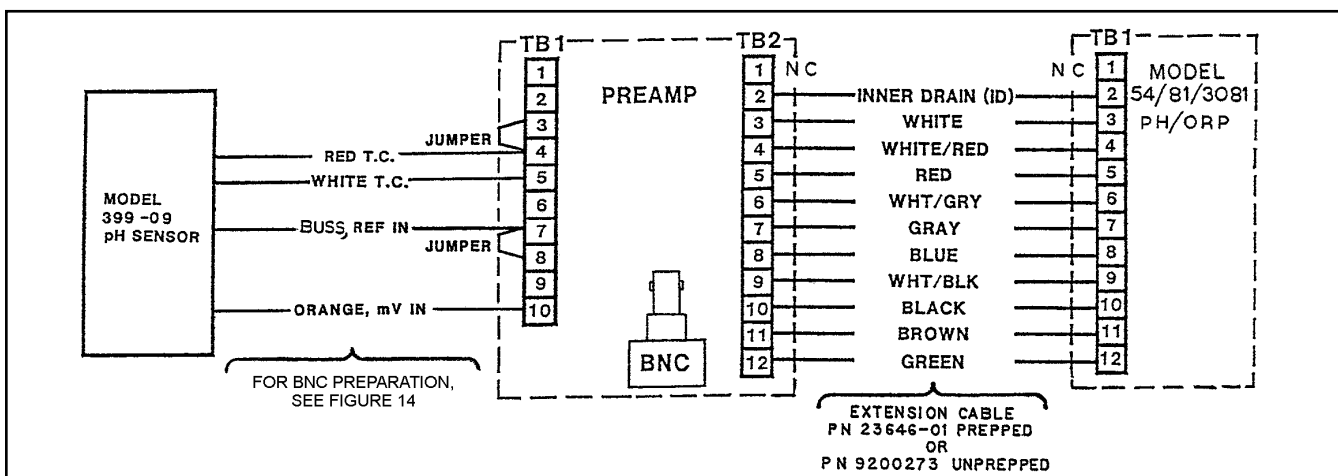

FIGURE 18. Wiring details - remote junction box with Model 399-09 sensor (without preamplifier)

NOTE: BNC from sensor cable (see Figure 14) must be cut and prepped. See Figure 15.

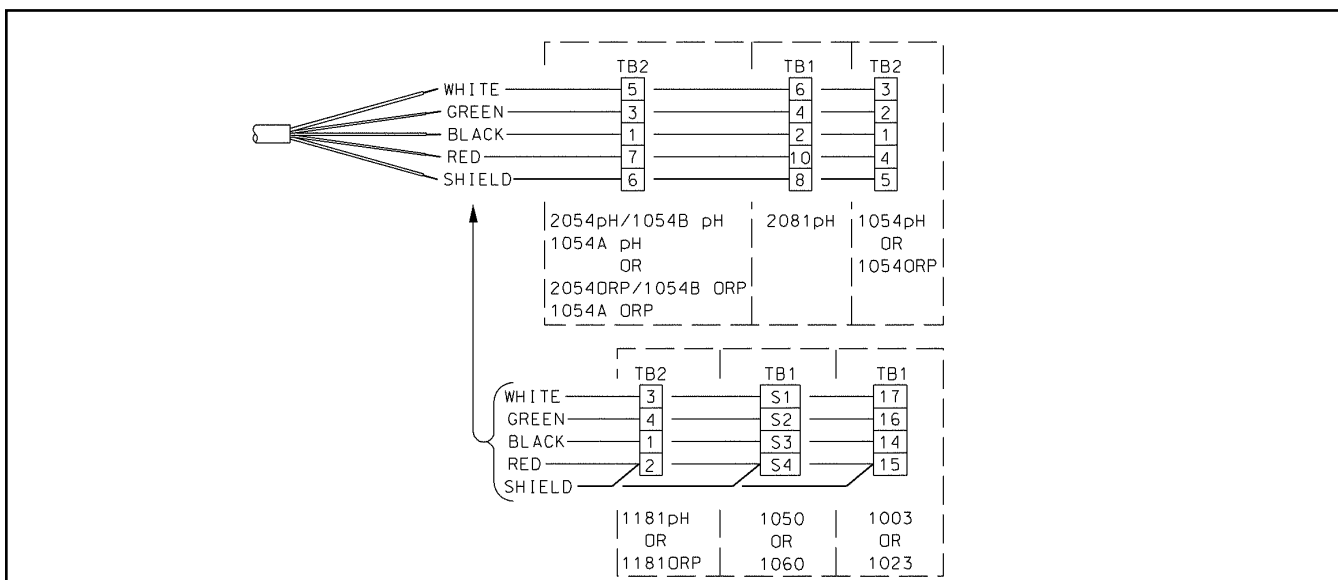

FIGURE 19. Wiring Model 399-01, -03, -05, -06, -07, and -08 (preamplifier integral to sensor) to Transmitter Models 2054, 1054A, 1054B, 2081, 1181, and other various models.

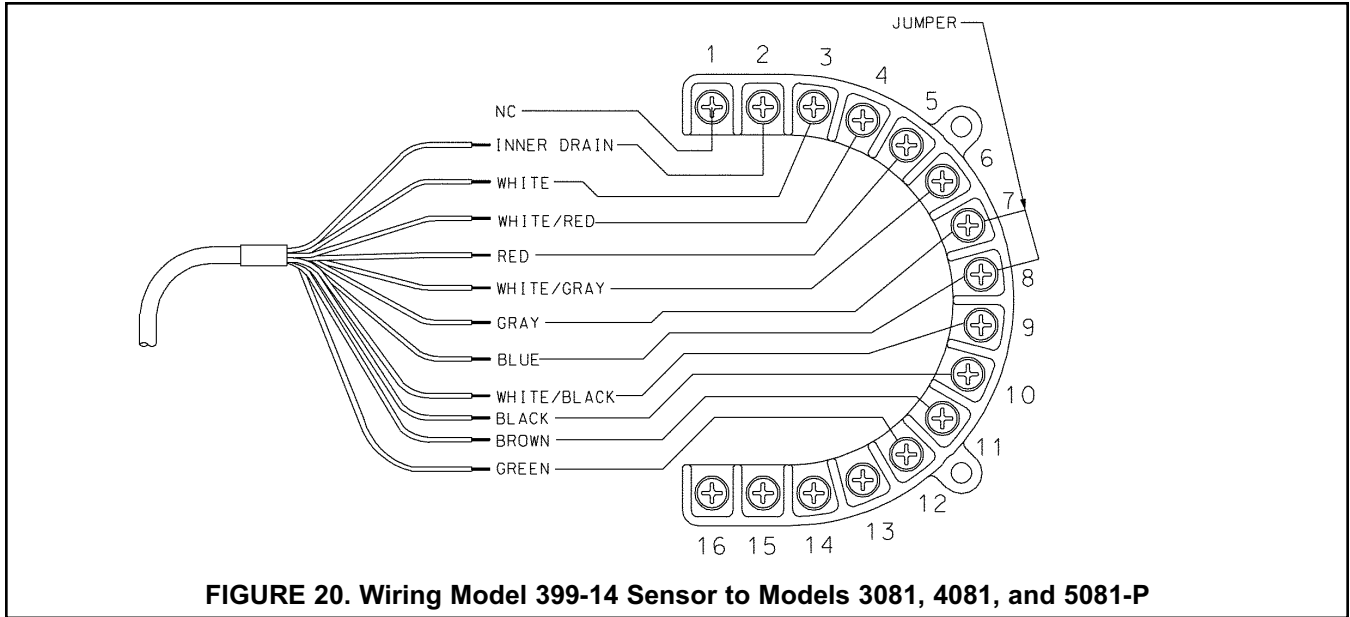

FIGURE 20. Wiring Model 399-14 Sensor to Models 3081, 4081, and 5081-P

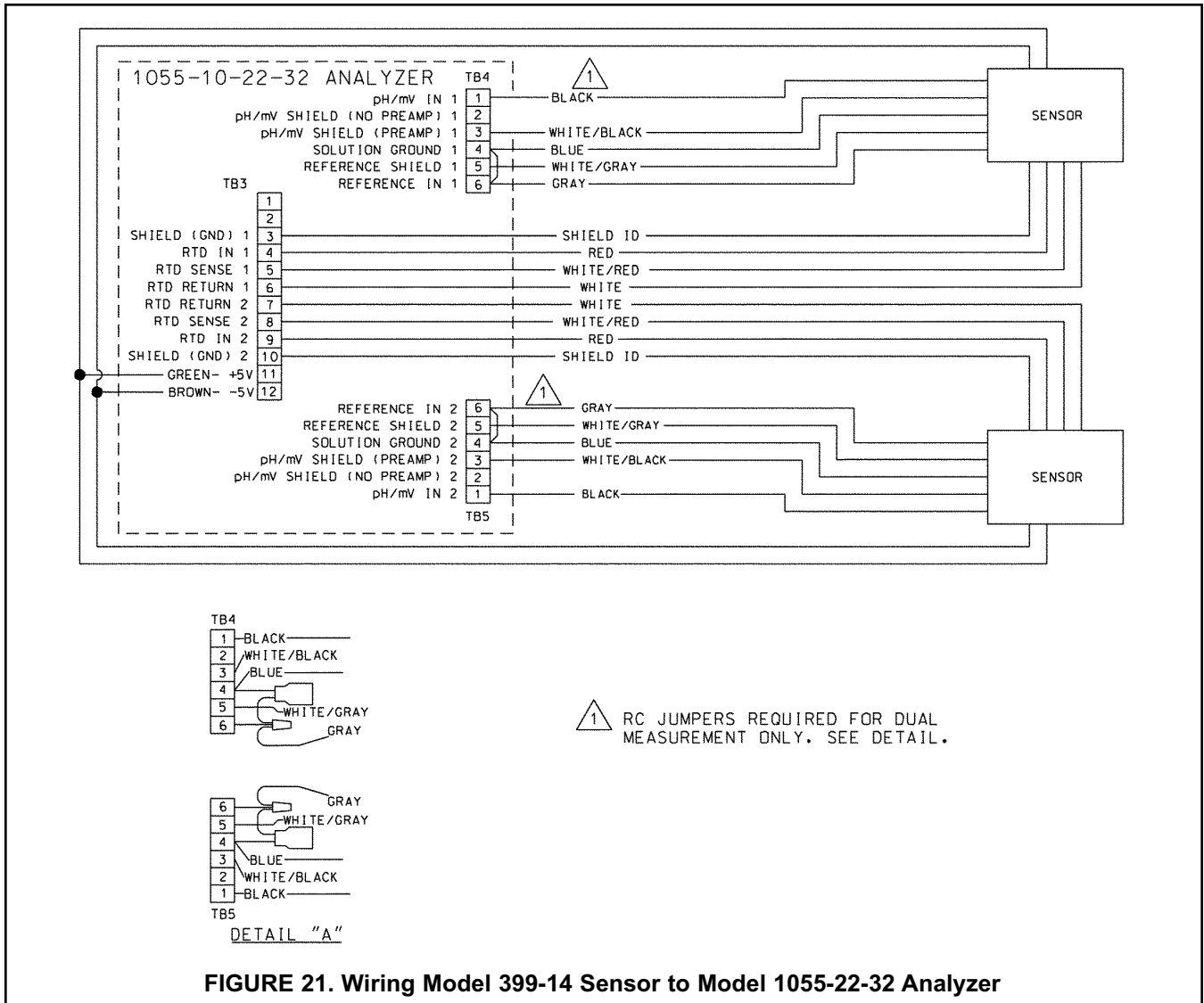
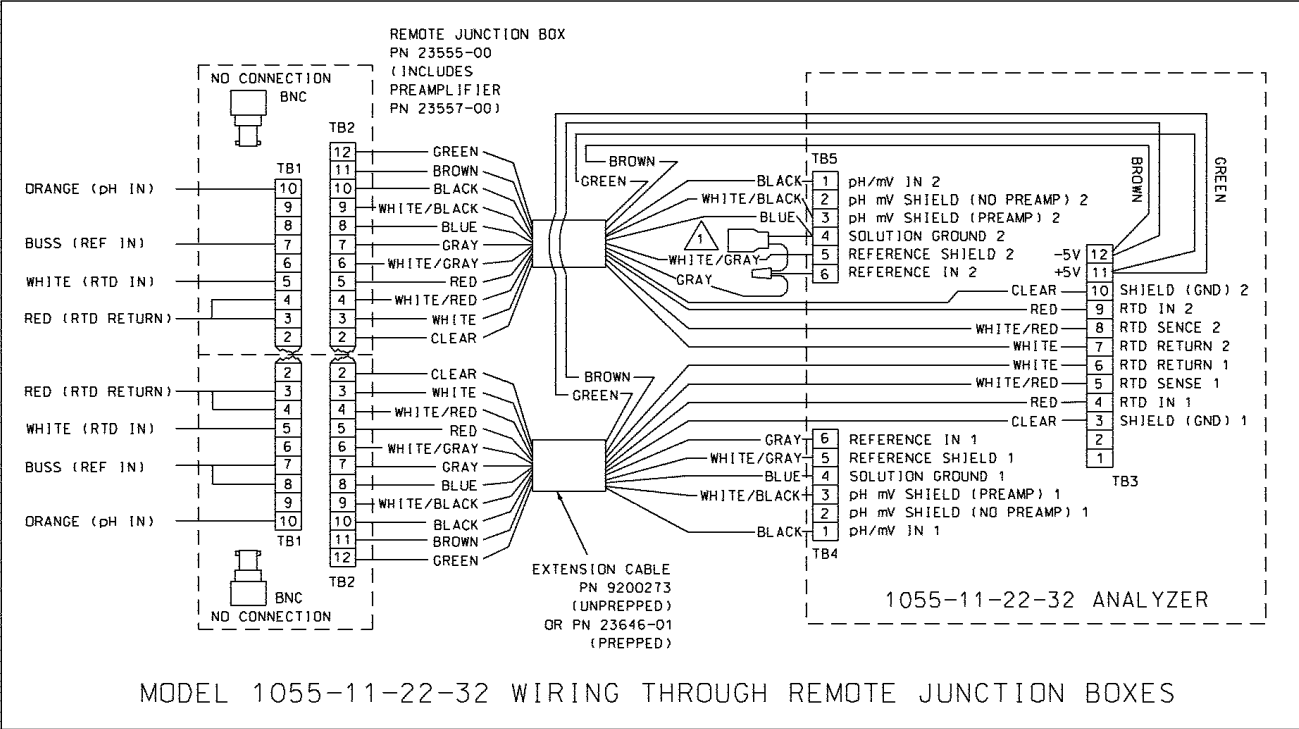
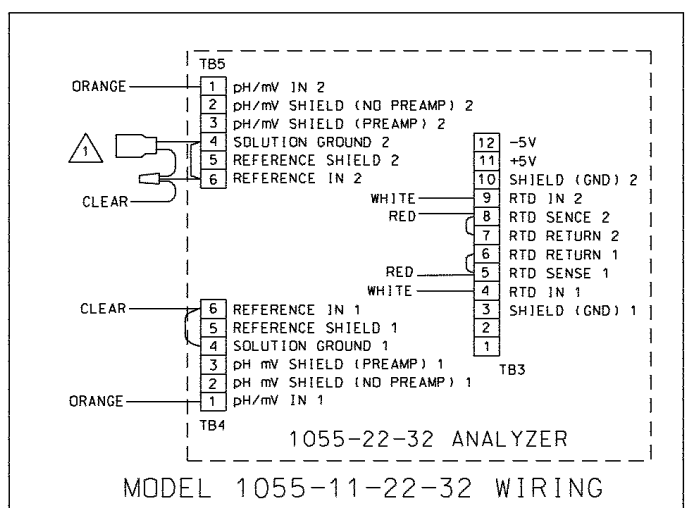
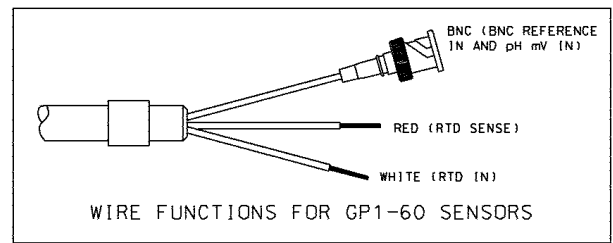
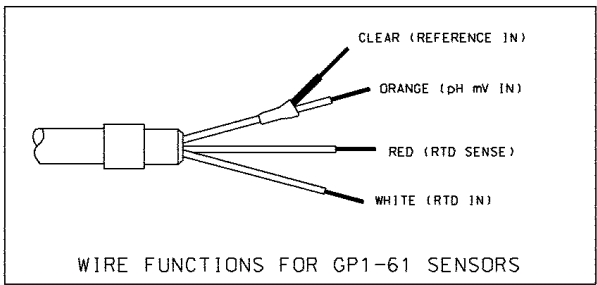

FIGURE 21. Wiring Model 399-14 Sensor to Model 1055-22-32 Analyzer



△ RC JUMPER REQUIRED FOR DUAL MEASUREMENT ONLY.

FIGURE 22. Wiring Model 399-09-62 Sensor to Model 1055-11-22-32 Analyzer through a Remote Junction Box

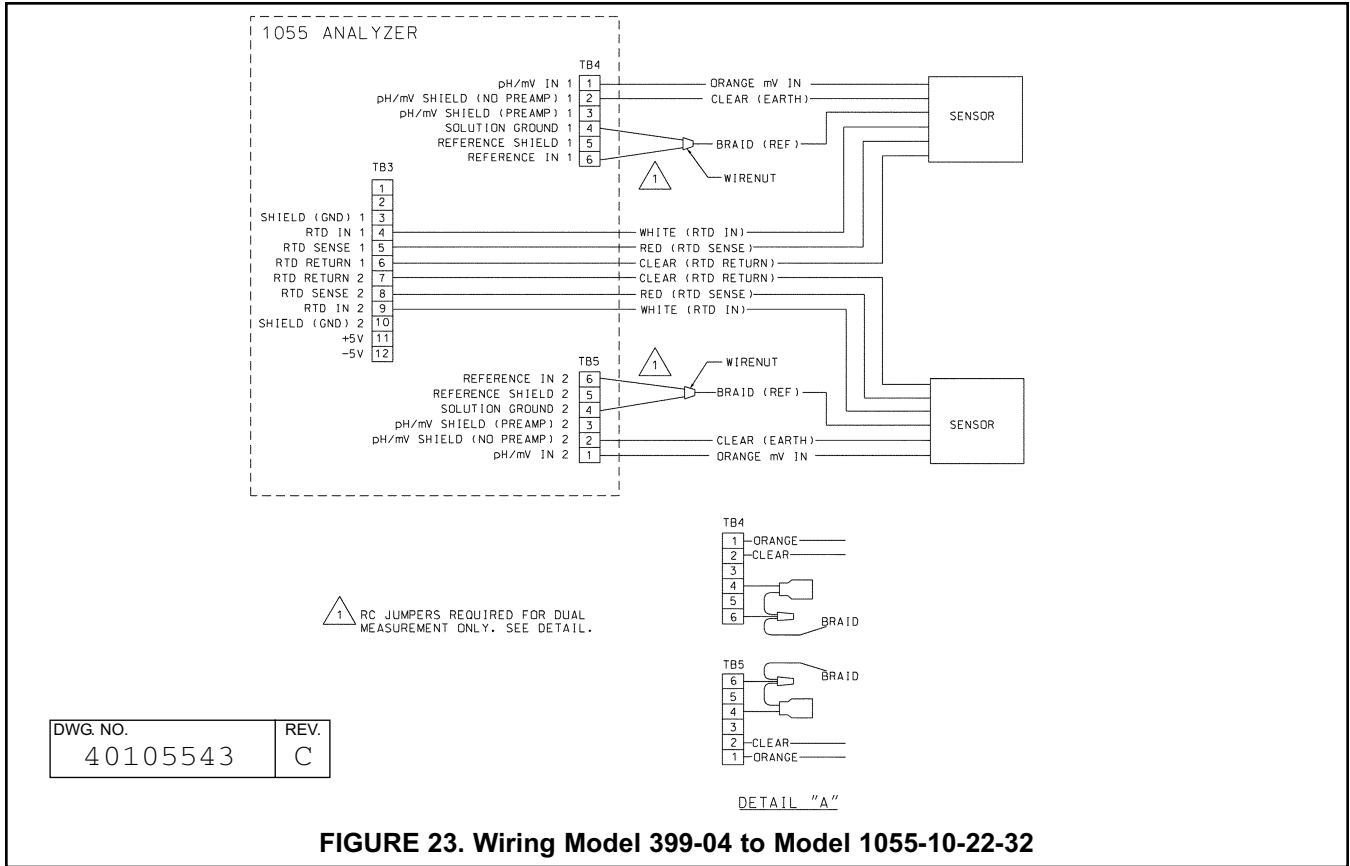

FIGURE 23. Wiring Model 399-04 to Model 1055-10-22-32

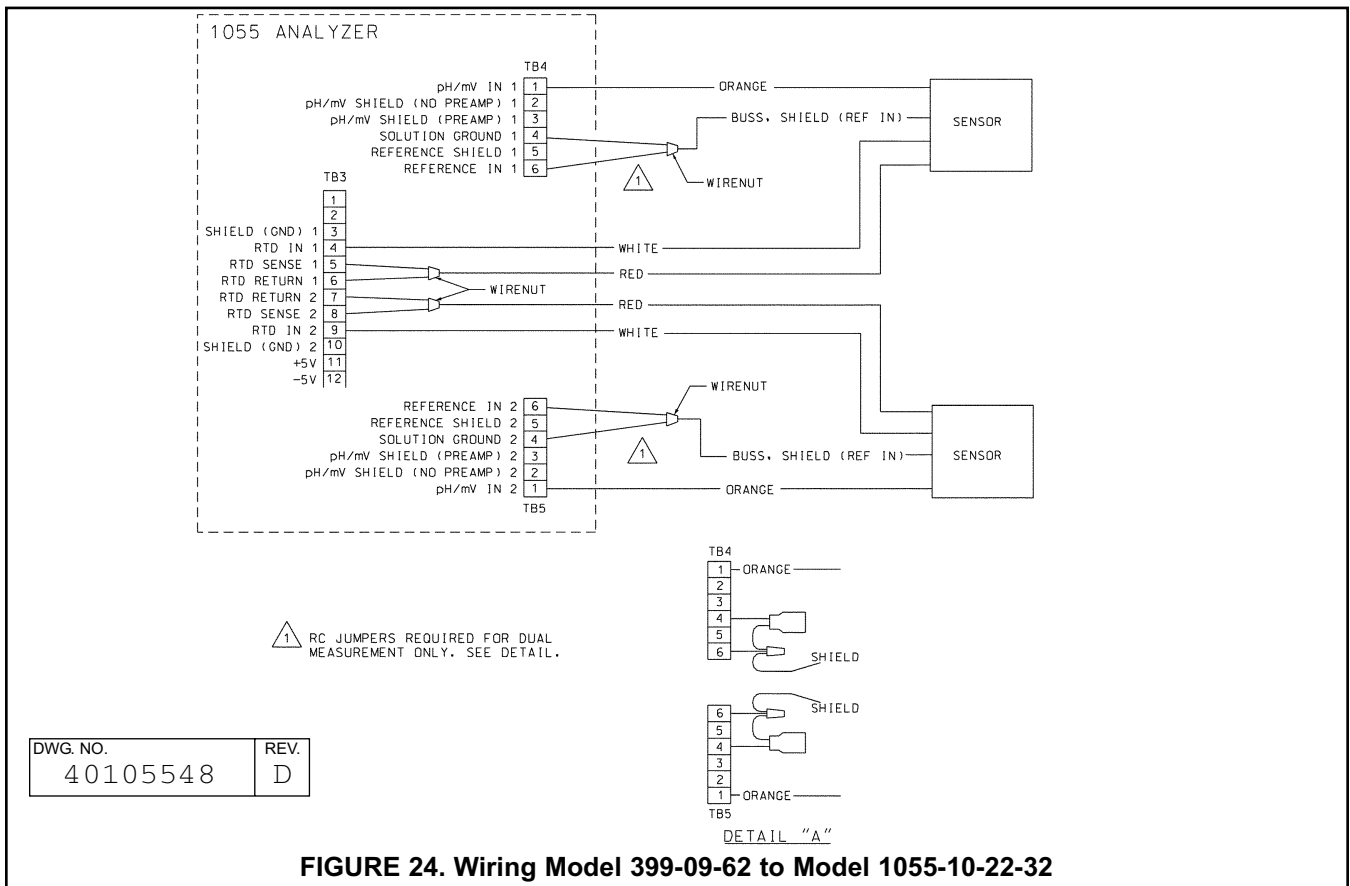

FIGURE 24. Wiring Model 399-09-62 to Model 1055-10-22-32

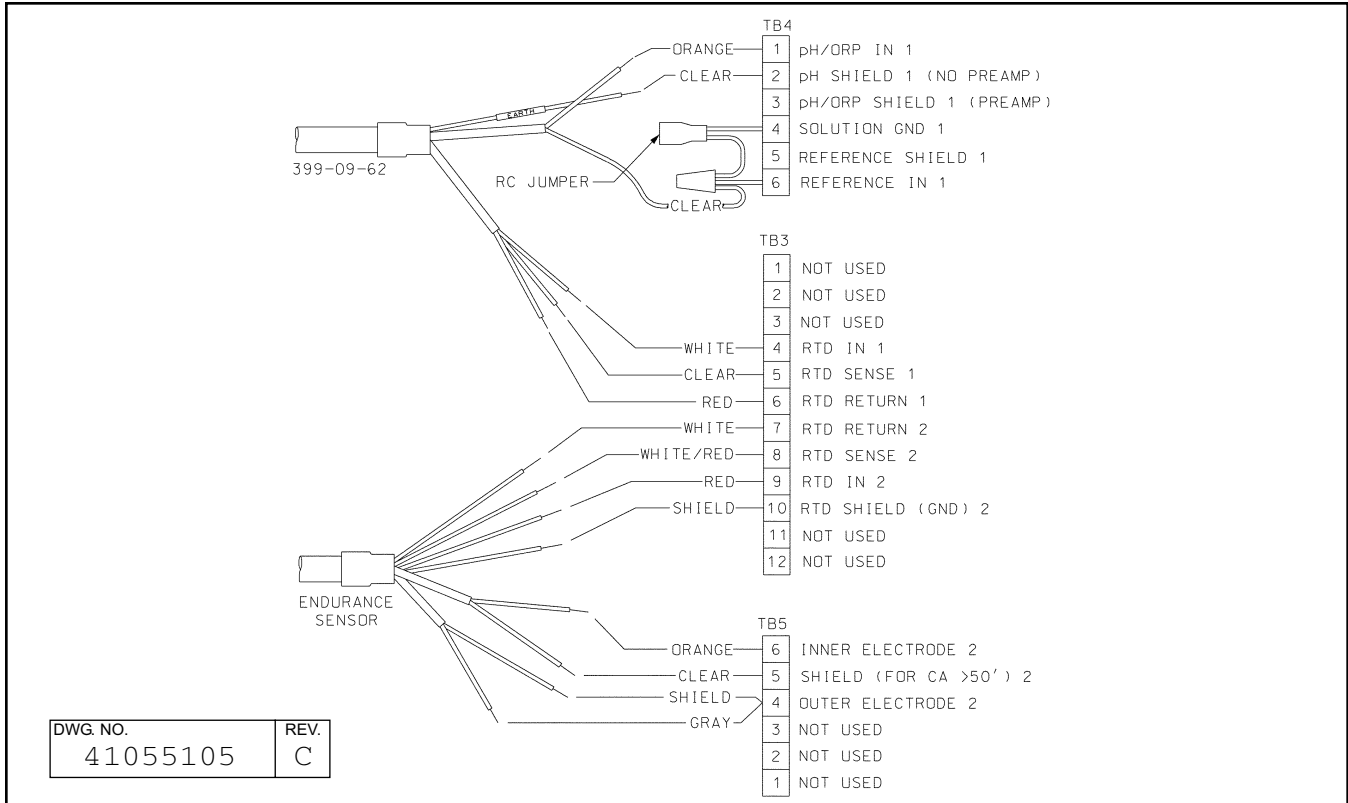

FIGURE 25. Wiring Model 399-09-62, 400, 401, 402, 403, and 404 to Model 1055 (Panel Mount)

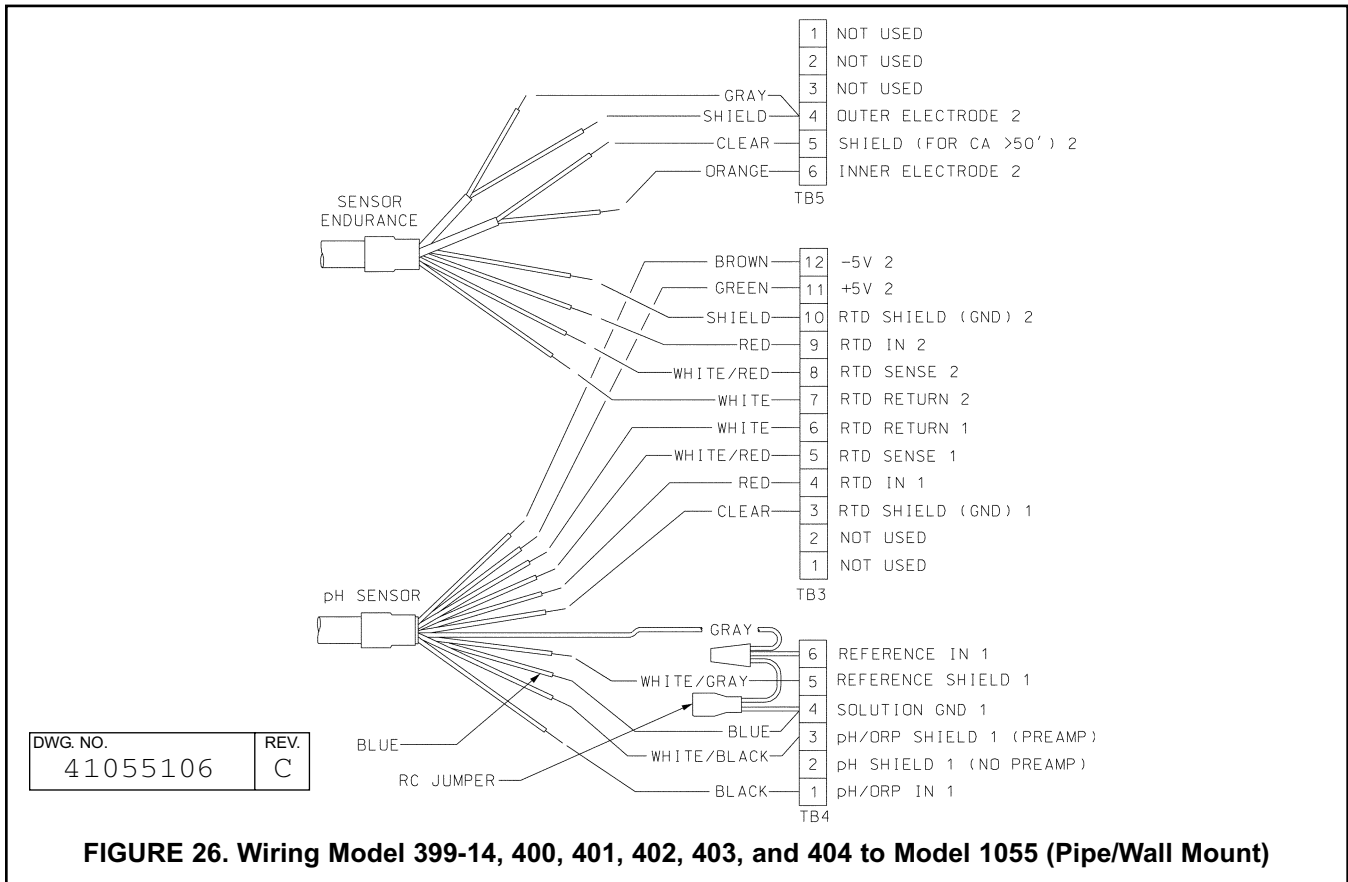
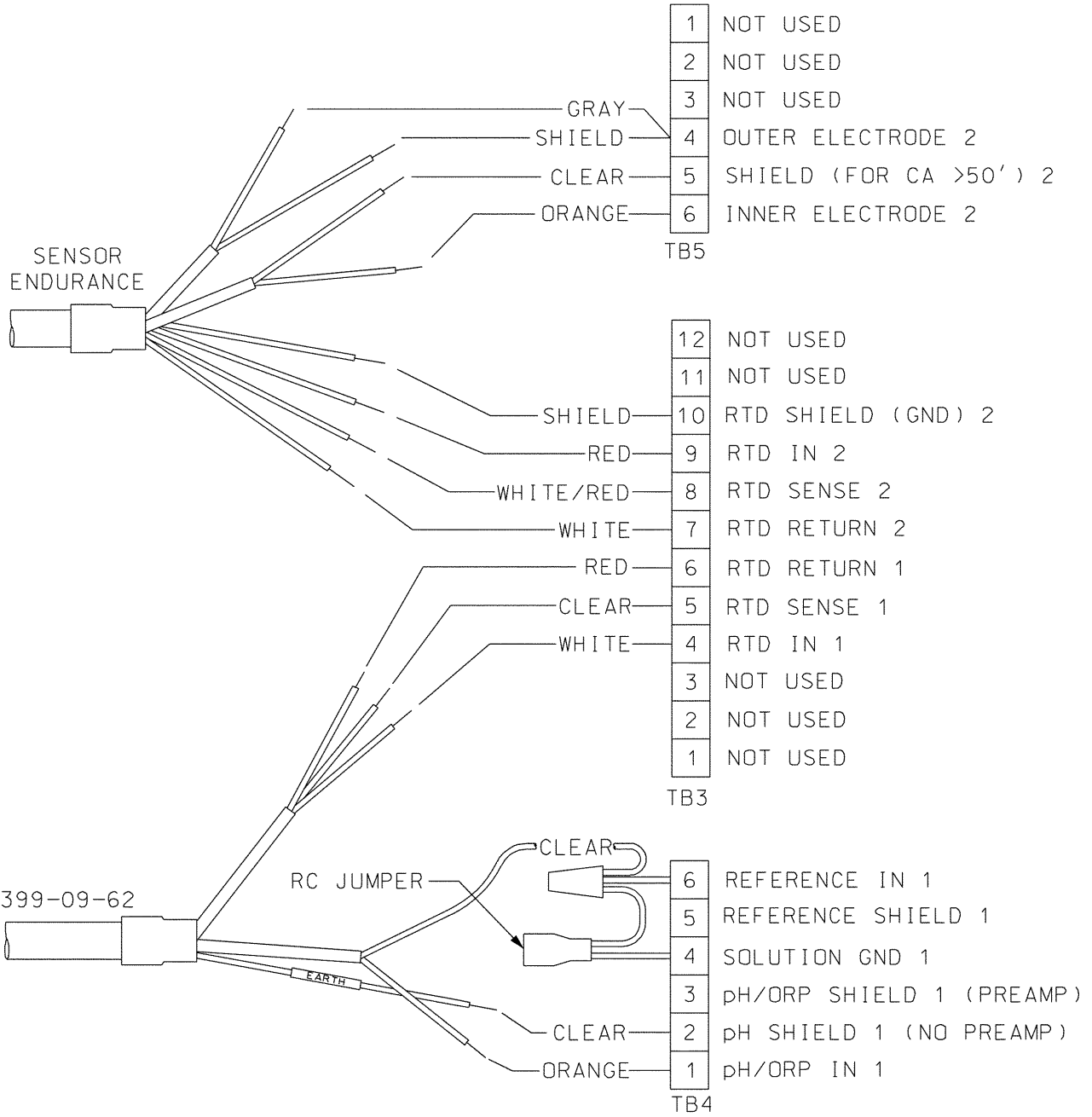
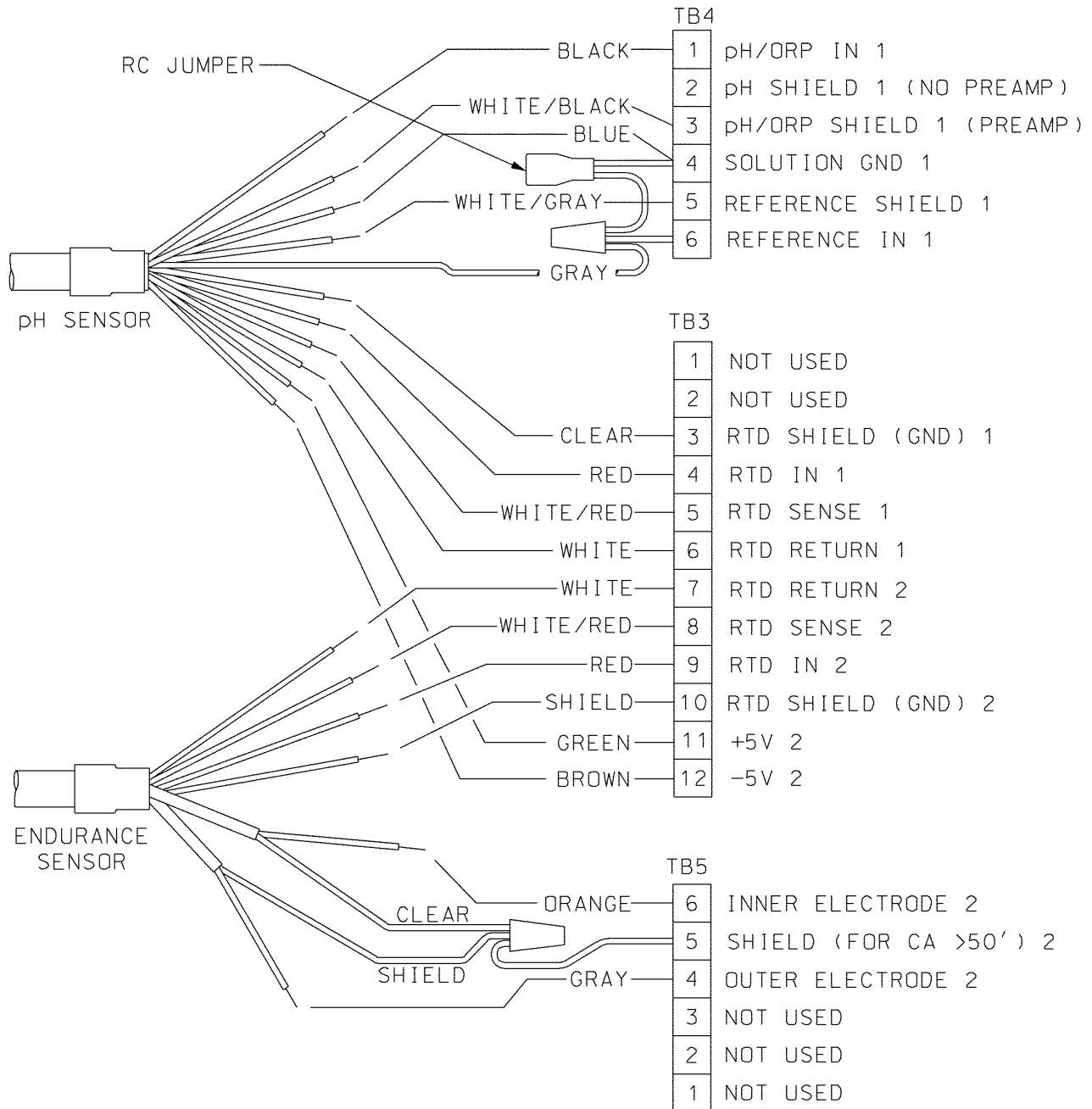

FIGURE 26. Wiring Model 399-14, 400, 401, 402, 403, and 404 to Model 1055 (Pipe/Wall Mount)



DWG. NO.	REV.
41055109	C

FIGURE 27. Wiring Model 399-09-62, 400, 401, 402, 403, and 404 to Model 1055 (Pipe/Wall Mount)



DWG. NO. 41055110	REV. D
----------------------	-----------

FIGURE 28. Wiring Model 399-14, 400, 401, 402, 403, and 404 to Model 1055 (Panel Mount)

ORDERING INFORMATION

The **Model 399 pH/ORP Sensor** is available with custom glass electrodes housed in a molded Tefzel body with 1 in. MNPT threads suitable for insertion, submersion or flow through installation. The sensor includes a general purpose hemi bulb pH electrode (flat bulb optional) or a platinum ORP electrode and a double junction gel filled reference electrode. The Model 399 pH is available with an optional integral hermetically sealed preamplifier. The Model 399 ORP is available only with an integral preamplifier. Automatic temperature compensation is standard with the Model 399 pH but is not required on the Model 399 ORP (except when used with the Model 1054A ORP Microprocessor Analyzer). Variable cable lengths are available for both the 399 pH and 399 ORP.

MODEL 399 pH/ORP SENSOR	
Code	399 pH (GPLR hemi bulb) Preamplifier/Cable (Required Selection)
01	10 ft cable with integral preamp for Models 1181pH & 1050
05	32 ft cable with integral preamp for Models 1181pH & 1050
03	10 ft cable with integral preamp for Model 1003
06	32 ft cable with integral preamp for Model 1003
07	10 ft cable with integral preamp for Model 1054A/B, 2054, and 2081 pH
08	32 ft cable with integral preamp for Model 1054A/B, 2054, and 2081 pH
02	10 ft coax cable for remote preamp, 3K ohm TC (Models 1181, 1050, and 1003)
04	10 ft cable for remote preamp, Pt100 TC (Solu Cube)
09	10 ft coax cable for remote preamp, Pt100 TC (Models 54e, 1054A/B, 1055, 2054, 2081, 81, 3081, 4081, 5081)
12	20 ft cable for Solu Comp (Formerly pH201)
13	100 ft cable for Solu Comp (Formerly pH201-Z100)
14	32 ft cable with integral preamp for Models 54e, 81, 1055, 3081, 4081, and 5081

OPTIONAL OPTIONS

Code	Specialized Glass Types (optional - choose one)
73	High pH (improved accuracy above 12.5 pH))
15	HF Resistant (up to 300 ppm)
71	GPLR Flat bulb (for abrasives)

Code	Specialized Reference Fills - valid only with standard hemi glass (optional - choose one)
301	Low ionic strength water, greater than 5 μ S/cm
302	Triple reference for improved resistance to poisoning ions (sulfide & heavy metals)
303	Low temperature storage (below freezing)

Code	Other Options
62	Cable prepped without BNC for wiring to Models 54e, 81, 3081, 4081, 5081, 2081 (only available w/option -09)

Code	399 ORP Preamplifier/Cable (Required Selection)
30	32 ft cable with integral preamp for Models 1181ORP and 1060
31	32 ft cable with integral preamp for Model 1023
32	32 ft cable with integral preamp for Model 1054A/B ORP
33	20 ft cable for Solu Comp (Formerly ORP-201)

399

01

73

EXAMPLE

FOR FIRST TIME MODEL 399 INSTALLATIONS AND REPLACEMENT PARTS, USE THE FOLLOWING GUIDE:**1. Mounting Accessories (optional)**

Choose one: PN 23242-02, Mounting adapter kit, 1/2 in. MNPT process connection, 1 in. x 3/4 in. sensor adapter
PN 915240-03, PVC flow through tee, 3/4 in. NPT process connection
PN 915240-04, PVC flow through tee, 1 in. NPT process connection
PN 915240-05, PVC flow through tee, 1-1/2 in. NPT process connection
PN 24091-00, Acrylic low flow cell
PN 2002011, 1-1/2 in. CPVC tee with 1-in. FNPT connection
PN 9320057, Pipe mount union, 1 in. x 1 in. PVC
PN 11275-01, Sensor handrail assembly
PN 1000857, Handrail mounting kit (pipe and sensor coupling supplied by others)

2. Junction Boxes (optional)

Remote Junction Boxes (to extend sensor to analyzer distances)

Choose one: PN 23555-00, includes preamplifier for Models 54, 81, 3081; NEMA 4X
PN 22719-02, Weatherproof junction box for cable extension
PN 23309-03, use with 1181 and 1050 compatible preamplifier
PN 23309-04, use with 1054/A/B, 2054, 2081 compatible preamplifier

3. Preamplifiers (used to amplify signal when mounting sensor further than 15 ft from the analyzer)

Choose one: PN 22698-02, Plug in preamplifier, 1181/1050 compatible (use with junction box PN 23309-03)
PN 22698-03, Plug in preamplifier, 1054/1054A/1054B/2054/ 2081 compatible (use with junction box PN 23309-04)

4. Extension cables (used with remote junction boxes)

Choose one: PN 23646-01, 11 conductor cable, shielded, prepped
PN 9200000, 4 conductor cable, shielded, unprepped

5. Other optional accessories

Choose one: PN 12707-00, Jet spray cleaner
PN 2001492, Stainless steel tag, specify marking (formerly Code -11)
PN 9210012, Buffer solution, 16 oz, 4.01 pH
PN 9210013, Buffer solution, 16 oz, 6.86 pH
PN 9210014, Buffer solution, 16 oz, 9.18 pH
PN 22698-00, Plug-in preamplifier, 1003 compatible
PN R508-16OZ, ORP solution, 460 mV \pm 10 @ 20°C

WARRANTY

Seller warrants that the firmware will execute the programming instructions provided by Seller, and that the Goods manufactured or Services provided by Seller will be free from defects in materials or workmanship under normal use and care until the expiration of the applicable warranty period. Goods are warranted for twelve (12) months from the date of initial installation or eighteen (18) months from the date of shipment by Seller, whichever period expires first. **Consumables, such as glass electrodes, membranes, liquid junctions, electrolyte, o-rings, catalytic beads, etc., and Services are warranted for a period of 90 days from the date of shipment or provision.**

Products purchased by Seller from a third party for resale to Buyer ("Resale Products") shall carry only the warranty extended by the original manufacturer. Buyer agrees that Seller has no liability for Resale Products beyond making a reasonable commercial effort to arrange for procurement and shipping of the Resale Products.

If Buyer discovers any warranty defects and notifies Seller thereof in writing during the applicable warranty period, Seller shall, at its option, promptly correct any errors that are found by Seller in the firmware or Services, or repair or replace F.O.B. point of manufacture that portion of the Goods or firmware found by Seller to be defective, or refund the purchase price of the defective portion of the Goods/Services.

All replacements or repairs necessitated by inadequate maintenance, normal wear and usage, unsuitable power sources, unsuitable environmental conditions, accident, misuse, improper installation, modification, repair, storage or handling, or any other cause not the fault of Seller are not covered by this limited warranty, and shall be at Buyer's expense. Seller shall not be obligated to pay any costs or charges incurred by Buyer or any other party except as may be agreed upon in writing in advance by an authorized Seller representative. All costs of dismantling, reinstallation and freight and the time and expenses of Seller's personnel for site travel and diagnosis under this warranty clause shall be borne by Buyer unless accepted in writing by Seller.

Goods repaired and parts replaced during the warranty period shall be in warranty for the remainder of the original warranty period or ninety (90) days, whichever is longer. This limited warranty is the only warranty made by Seller and can be amended only in a writing signed by an authorized representative of Seller. Except as otherwise expressly provided in the Agreement, THERE ARE NO REPRESENTATIONS OR WARRANTIES OF ANY KIND, EXPRESS OR IMPLIED, AS TO MERCHANTABILITY, FITNESS FOR PARTICULAR PURPOSE, OR ANY OTHER MATTER WITH RESPECT TO ANY OF THE GOODS OR SERVICES.

RETURN OF MATERIAL

Material returned for repair, whether in or out of warranty, should be shipped prepaid to:

**Emerson Process Management
Liquid Division
2400 Barranca Parkway
Irvine, CA 92606**

The shipping container should be marked:

Return for Repair
Model _____

The returned material should be accompanied by a letter of transmittal which should include the following information (make a copy of the "Return of Materials Request" found on the last page of the Manual and provide the following thereon):

1. Location type of service, and length of time of service of the device.
2. Description of the faulty operation of the device and the circumstances of the failure.
3. Name and telephone number of the person to contact if there are questions about the returned material.
4. Statement as to whether warranty or non-warranty service is requested.
5. Complete shipping instructions for return of the material.

Adherence to these procedures will expedite handling of the returned material and will prevent unnecessary additional charges for inspection and testing to determine the problem with the device.

If the material is returned for out-of-warranty repairs, a purchase order for repairs should be enclosed.



*The right people,
the right answers,
right now.*

**ROSEMOUNT ANALYTICAL
CUSTOMER SUPPORT CENTER
1-800-854-8257**

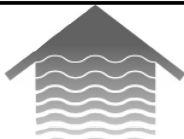

**ON-LINE ORDERING NOW AVAILABLE ON OUR WEB SITE
<http://www.raihome.com>**

Specifications subject to change without notice.



Credit Cards for U.S. Purchases Only.



Emerson Process Management

Liquid Division

2400 Barranca Parkway
Irvine, CA 92606 USA
Tel: (949) 757-8500
Fax: (949) 474-7250

<http://www.raihome.com>