

20. Warranty

OAKTON warrants this meter to be free from significant deviations in material and workmanship for a period of one year from date of purchase. OAKTON warrants this probe to be free from significant deviations in material and workmanship for a period of six months from date of purchase. If repair or adjustment is necessary and has not been the result of abuse or misuse within the warranted time period, please return—freight prepaid—and correction will be made without charge. OAKTON alone will determine if the product problem is due to deviations or customer misuse.

Out-of-warranty products will be repaired on a charge basis.

21. Return of items

Authorization must be obtained from our Customer Service Department before returning items for any reason. When applying for authorization, please include data regarding the reason the items are to be returned. For your protection, items must be carefully packed to prevent damage in shipment and insured against possible damage or loss. We will not be responsible for damage resulting from careless or insufficient packing. A restocking charge will be made on all unauthorized returns.

NOTE: We reserve the right to make improvements in design, construction, and appearance of products without notice.

68X075502

00806-11

OAKTON®

OPERATING INSTRUCTIONS

OAKTON® 35607-10, -20

Portable Conductivity/°C Meters

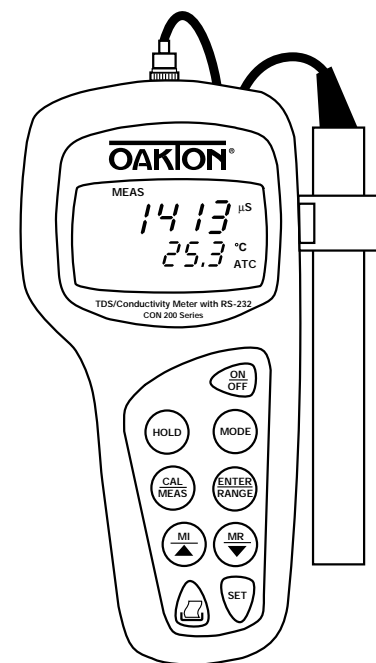

Printed in Singapore 6/00 R7

OAKTON®

Table of Contents

- 1. Introduction.....3
- 2. Display and keypad functions4-5
 - 2.1 Display4
 - 2.2 Keypad5
- 3. Preparation6-9
 - 3.1 Inserting the batteries6
 - 3.2 Connecting the conductivity cell and temperature sensor7
 - 3.3 Attaching the electrode holder to the meter8
 - 3.4 Inserting the electrode into the electrode holder8
 - 3.5 Attaching two electrode holders9
 - 3.6 Connecting the optional AC adapter9
- 4. Calibration10-17
 - 4.1 Important information on meter calibration10
 - 4.2 Preparing the meter for calibration11
 - 4.3 Conductivity calibration12-13
 - 4.4 TDS calibration14-15
 - 4.5 Temperature calibration16
 - 4.6 Errors in calibration17
- 5. Measurement18-21
 - 5.1 Automatic Temperature Compensation18
 - 5.2 Manual Temperature Compensation19
 - 5.3 Taking Measurements20
 - 5.4 Using the manual ranging function21
- 6. Hold function22
- 7. Memory and data input22-23
 - 7.1 Memory Input22
 - 7.2 Memory Recall23
- 8. SETUP functions24-31
 - 8.1 SETUP Functions at a Glance24
 - 8.2 General Instructions for all SETUP Programs25
 - 8.3 Program 1: Stored Values26-27
 - 8.4 Program 2: Meter Function28-29
 - 8.5 Program 3: TDS Function30
 - 8.6 Program 4: Communication Set-up31
- 9. Optional Printer and RS-232 Output Setup32-43
 - 9.1 Using with an OAKTON Printer32
 - 9.2 Using with a non-OAKTON Printer32-34
 - 9.3 Using with a Printer to Download Stored Memory35
 - 9.4 Using with a Computer and the OAKTON Datalog Assist Software36-40
 - 9.5 Sending Data to the Computer41
 - 9.6 Using with a Computer and the OAKTON Datalog Assist Software to Download Stored Memory42
 - 9.7 View a Data File43
 - 9.8 Printing Errors43
- 10. Probe care and maintenance.....44
- 11. Probe Replacement45-46
 - 11.1 Zero Adjustment45
 - 11.2 Two Point Temperature Calibration46

- 12. Troubleshooting47
- 13. Error Messages48
- 14. Specifications49
- 15. Accessories50-51
- 16. Addendum 1: Conductivity to TDS Conversion Factors52
- 17. Addendum 2: Calculating TDS Conversion Factors53
- 18. Addendum 3: Calculating Temperature Coefficients54
- 19. Addendum 4: Calibration Tips55
- 20. Warranty56
- 21. Return of Items56

1. Introduction

Thank you for selecting an OAKTON meter. The OAKTON Conductivity/°C; or TDS/Conductivity/°C with RS-232 are portable microprocessor-based instruments that measure conductivity or TDS (models WD-35607-20) and temperature. This meter has many user-friendly features—all of which are completely accessible through the water-resistant membrane keypad.

Your meter includes two electrode holders; epoxy platinum probe WD-35607-50 with built-in temperature sensor and cable; batteries and OAKTON PC Datalog Assist Software on a 3½” disk (model WD-35607-20 only).

Please read this manual thoroughly before operating your meter.

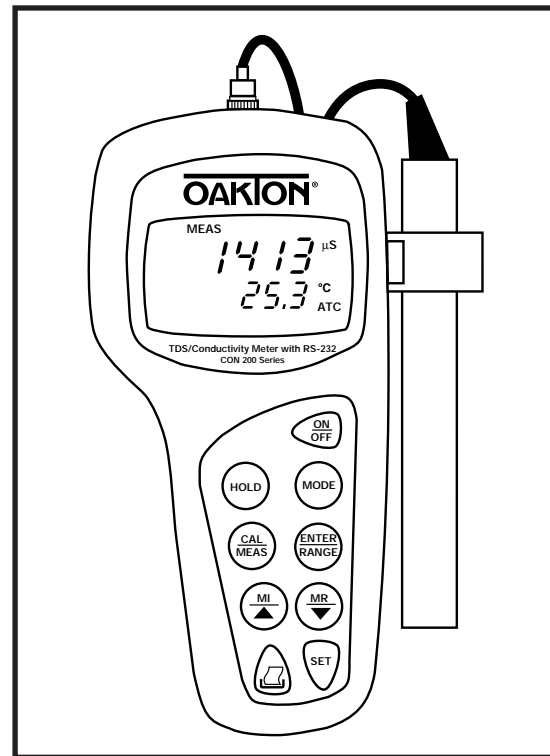

2. Display and Keypad Functions

2.1 Display

The LCD has a primary and secondary display.

- The primary display shows the measured Conductivity or TDS.
- The secondary display shows the temperature of the reading in °C.

The display also shows error messages, keypad functions and program functions.

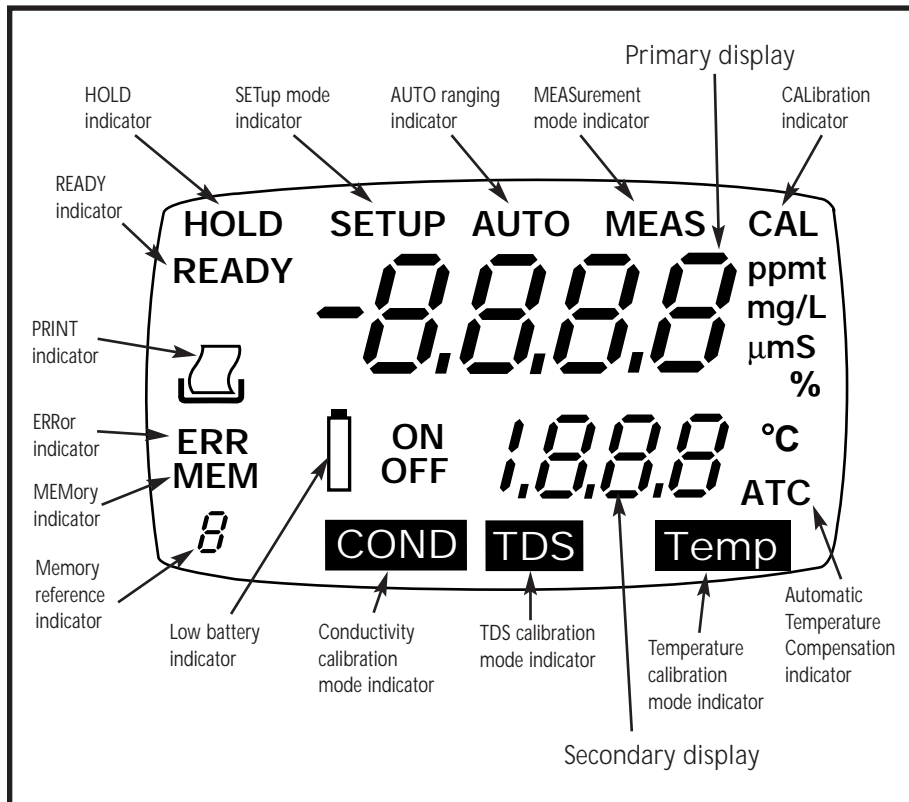

2.2 Keypad

The large membrane keypad makes the instrument easy to use. Each button, when pressed, has a corresponding graphic indicator on the LCD.

ON/OFFPowers and shuts off the meter.

HOLDFreezes the measured reading. To activate, press **HOLD** while in measurement mode. To release, press **HOLD** again

MODESelects the measurement (or calibration) parameter conductivity, TDS (model 35607-20) or temperature. Press **MODE** to toggle between conductivity, TDS and temperature mode.

CAL/MEASToggles user between Calibration and Measurement mode.

- If you were in conductivity measurement mode, press **CAL/MEAS** to enter conductivity calibration mode.
- If you were in TDS measurement mode, press **CAL/MEAS** to enter TDS calibration mode.

NOTE: Manual Temperature compensation is accessible from temperature mode; see page 19 for instructions.

ENTER/RANGE....In Measurement mode—selects range or sets units to auto ranging. In Calibration mode—confirms calibration values.

MI / MR▲ /▼ scrolls values up and down in Calibration and **SETUP** mode.

MI/MR work in the measurement mode. **MI** (memory input) stores the measured value into memory. **MR** (memory recall) recalls the sets of values stored in the memory.

PRINTSends measurement to either the printer or computer. On models with RS-232 /printer option only.

SETEnters the **SETUP** mode. Lets you customize the preferences and defaults.

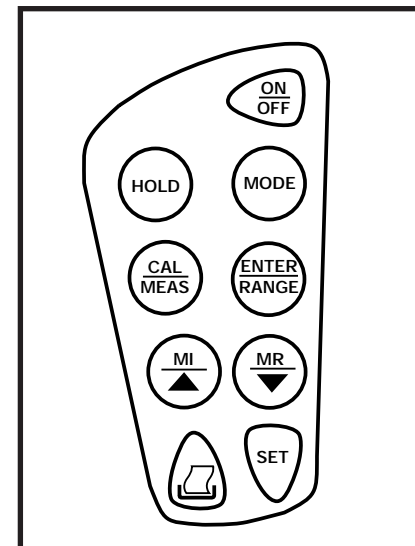

3. Preparation

3.1 Inserting the Batteries

Four AAA batteries are included with your meter.

1. Use a Phillips screwdriver to remove the two screws holding the battery cover. See Figure below.
2. Lift meter stand to expose battery cover. Remove battery cover.
3. Insert batteries. Follow the diagram inside the cover for correct polarity.
4. Replace the battery cover into its original position using the two screws removed earlier.

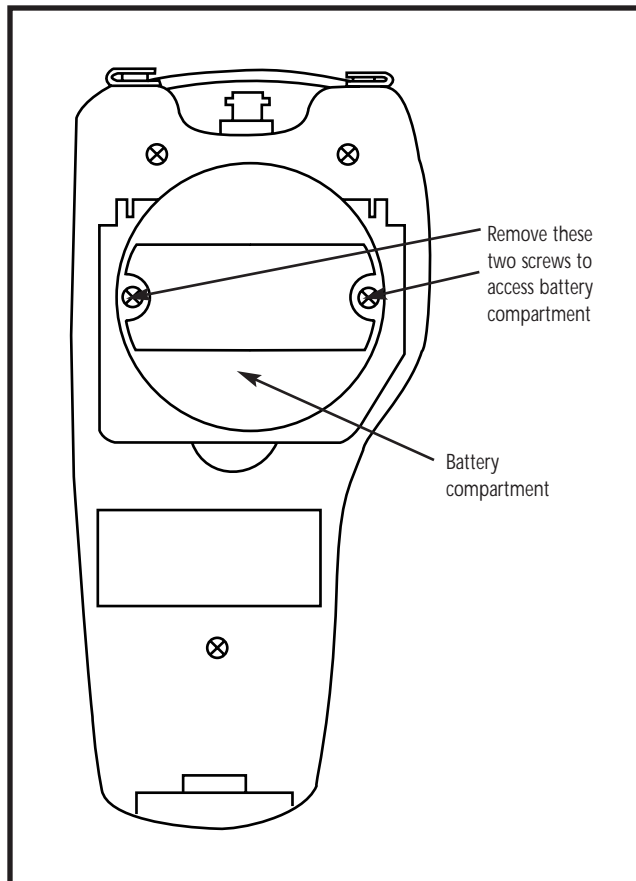

3.2 Connecting the Conductivity Cell and Temperature Sensor

The OAKTON Conductivity and TDS/Conductivity with RS-232 meter includes conductivity probe WD-35607-50 with built-in temperature sensor and cable.

NOTE: Keep connector dry and clean. Do not touch connector with soiled hands.

To connect the conductivity probe:

1. Slide the BNC connector of the probe over the BNC connector socket on the meter. Make sure the slots of the connector are in line with the posts of the socket. Rotate and push the connector clockwise until it locks

See figure **A**

2. To remove probe, push and rotate the connector counter clockwise. While holding onto the metal part of the connector, pull probe away from the meter.

CAUTION: Do not pull on the probe cord or the probe wires might disconnect.

To connect the temperature probe:

1. Plug temperature in the phone jack as shown in figure **B**

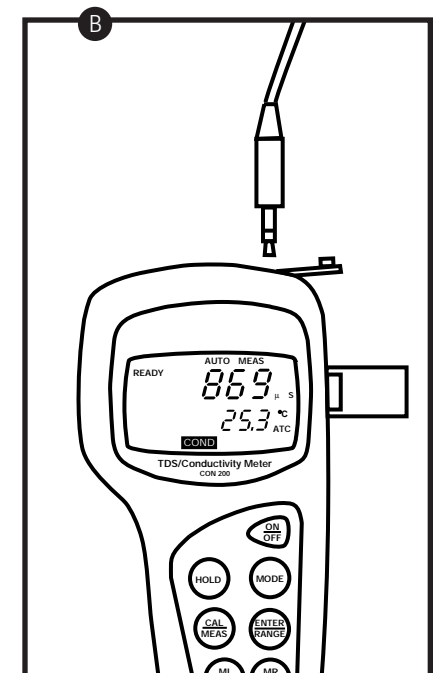
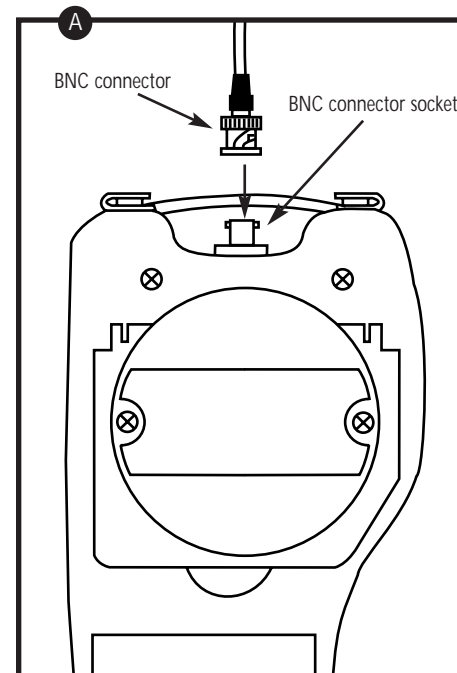

3.3 Attaching the Electrode Holder to the Meter

1. Place the electrode holder with the flange facing the slot on the meter.
See Figure A
2. Gently slide the flange of the holder into the slot on the meter. Make sure the holder is secured properly into the slot.

You can attach the electrode holder in different positions.
See figure B

This flexibility facilitates one-hand operation.

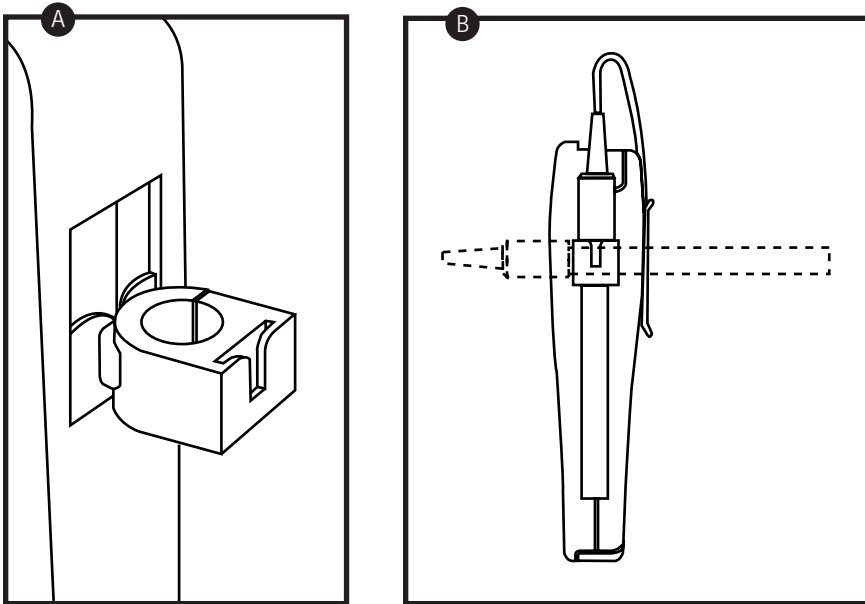

3.4 Inserting the Electrode into the Electrode Holder

Two electrode holders are included with your meter.

NOTE: Do not use excessive force when inserting electrode into the holder.

1. Insert the conductivity/temperature electrode into the opening of the holder until the top housing of the electrode touches the top of the holder.

NOTE: The holder is designed for probes 12 mm in diameter. Electrodes larger than 12 mm may not fit in the holder. Forcing the electrode into the opening may damage the holder or your electrode.

3.5 Attaching Two Electrode Holders

1. Align the flange of the second electrode holder with the slot of the first holder.
See Figure C
2. Slide the flange of the second holder into the slot of the first holder until the tops of the holders are aligned and secure.

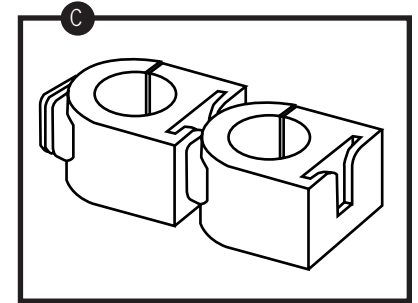

3.6 Connecting the AC Adapter

The AC adapter is not included with your meter; order separately on page 50.

1. Insert the AC jack as shown in figure D below.
2. **Switch off the meter before plugging the adapter into the power source.**
This safety precaution protects the software in your meter.
3. Press the ON/OFF button to switch meter on.

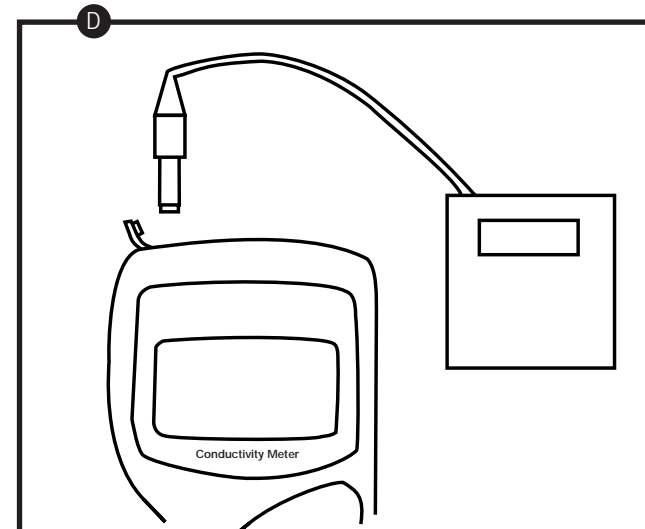

4. Calibration

4.1 Important Information on Meter Calibration

When you recalibrate your meter, old conductivity and TDS calibrations are replaced on a range basis. For example, if you previously calibrated your meter at 1413 μS in the 0 to 1999 μS range and you recalibrate at 1500 μS also in the 0 to 1999 μS range, the meter will replace the old calibration data (1413 μS) in that range. The meter will retain all other calibration data in other ranges. To view current calibration points see Program 1, P1.2 in the *SETUP* section on page 27.

For meters that also measure TDS (WD-35607-20), calibrating the meter in a conductivity range also calibrates the corresponding TDS range. A calibration value in the TDS mode of a particular range replaces a prior calibration value in the corresponding conductivity mode if both fall in the same range and vice versa. The following table lists the corresponding conductivity and TDS ranges:

| Conductivity Range | Function Keys |
|--------------------------|------------------------------|
| 0.00-19.99 μS | 0.00-9.99 ppm |
| 0.0-199.9 μS | 10.0-99.9 ppm |
| 0-1999 μS | 100-999 ppm |
| 0.00-19.99 mS | 1.00-9.99 ppt |
| 0.0-199.9 mS | 10.0-99.9 ppt 100-200 ppt |

You can calibrate to separate points in each of the five measuring ranges. If you are measuring values in more than one range you should calibrate at multiple standard values to cover those ranges.

To completely recalibrate your meter, or when you use a replacement probe, it is best to clear all calibration data in memory. To erase all old conductivity and TDS calibration data completely from memory, see the *SETUP* section Program 2, P 2.2 on page 28.

For information on how to calibrate your meter:

- See section 4.3 on pages 12-13 for Conductivity Calibration
- See section 4.4 on pages 14-15 for TDS Calibration
- See section 4.5 on page 16 for Temperature Calibration
- See section 4.6 on page 17 for Errors in Calibration

4.2 Preparing the Meter for Calibration

Before starting calibration, make sure you are in the correct measurement mode. When you switch on the meter, the meter starts up in the units you shut it off in (either conductivity or TDS depending on model). For example, if you shut the meter off in “ppm” units, the meter will read “ppm” units when you switch the meter on.

For best results, select a conductivity or TDS standard value close to the sample value you are measuring. Alternatively use a calibration solution value that is approximately $\frac{1}{2}$ the full scale value of the measurement range you plan to use. For example in the 0 to 1999 μS range, use a 1413 μS solution for calibration.

Do not reuse calibration solutions after calibration. Contaminants in the solution can affect the calibration, and eventually the accuracy of the measurements. Use fresh calibration solution each time you calibrate your meter.

NOTE: These meters are factory set to a temperature coefficient of 2% per $^{\circ}\text{C}$. For most applications this will provide good results. See Program 1, P1.1 on page 26 to set the temperature coefficient to a different value. See Addendum 3, “Calculating Temperature Coefficients” on page 54 to determine the appropriate temperature coefficient for your solution.

4.3 Conductivity calibration

This instrument is capable of up to 5-point conductivity calibration at one point per conductivity range (0.00-19.99 μS ; 0.0-199.9 μS ; 0-1999 μS ; 0.00-19.99 mS ; 0.0-199.9 mS)

Calibrating for conductivity:

1. If necessary, press the MODE key to select conductivity mode. The COND indicator appears in the lower left hand corner of the display.

See figure A

2. Rinse the probe thoroughly with de-ionized water or a rinse solution, then rinse with a small amount of calibration solution.
3. Dip the probe into the calibration solution. Immerse the probe tip at least $\frac{1}{2}$ inch into the solution. Stir the probe gently to create a homogeneous sample.
4. Press CAL/MEAS to enter conductivity calibration mode. The CAL indicator will flash in the upper right corner of the display.

See figure B

5. Press the MI/ \blacktriangle or MR/ \blacktriangledown to change the value on the primary display to match the value of the calibration standard.
NOTE: If the value input into the meter differs from the initial value displayed by more than 20% the "ERR" indicator will flash. "ERR" signals improper probe use, a bad calibration solution, or bad calibration technique.

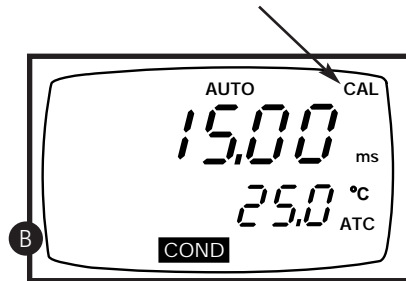
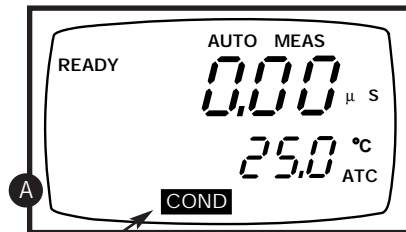

6. Press ENTER to confirm the calibration value. The meter returns to the MEAS (measurement) mode.
7. Repeat steps 1-6 for other measuring ranges.

Notes

To exit from Conductivity Calibration mode without confirming calibration, DO NOT press ENTER in step 6. Press CAL/MEAS instead. This will retain the meter's old calibration data in the measuring range of the calibration.

4.4 TDS Calibration (WD-35607-20)

TDS conversion factors:

TDS values are related to conductivity. You can calibrate the meter using conductivity standards as described on page 12 and then program the meter with a given conversion factor. Enter the conversion factor using the Conductivity to TDS Conversion Factor program see page 30, Program 3, P3.0.

Select the conductivity to TDS conversion factor for your solution. Addendum 1 on page 52 lists some commonly used conversion factors. You can calculate the TDS conversion factor for other solutions as shown in Addendum 2, page 53.

Alternatively, you can calibrate directly to TDS standards using the method below:

Calibrating for TDS:

1. **While in the measurement function, press MODE** to enter the TDS mode. The TDS indicator appears in the bottom center of the display.

See figure **A**

2. **Rinse the probe thoroughly with de-ionized water or a rinse solution, then rinse with a small amount of calibration solution.**
3. **Dip the probe into the calibration solution.** Immerse the probe tip at least ½ inch into the solution. Stir the probe gently to create a homogeneous sample.
4. **Press CAL/MEAS** to enter TDS calibration mode. The CAL indicator will flash in the upper right corner of the display.

See figure **B**

5. **Press the MI/▲ or MR/▼** to change the value on the primary display to match the value of the calibration standard.
NOTE: If the value input into the meter differs from the initial value displayed by more than 20% the “ERR” indicator will flash. “ERR” signals improper probe use, a bad calibration solution, or bad calibration technique.

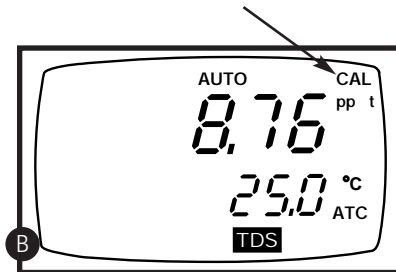
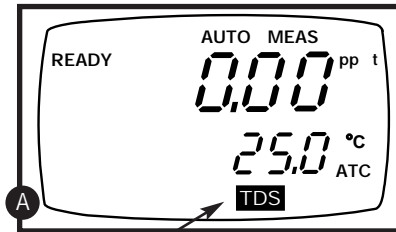

6. **Press ENTER** to confirm the calibration value. The meter returns to the MEAS (measurement) mode.
7. **Repeat steps 1-6 for other measuring ranges.**

Notes

To exit from TDS Calibration mode without confirming calibration, DO NOT press ENTER in step 6. Press CAL/MEAS instead. This will retain the meter's old calibration data in the measuring range of the calibration.

4.5 Temperature Calibration

The meter allows two types of temperature calibrations called “single point” and “two point” calibrations. Single point calibration is more commonly used. A two point calibration is needed only if you are using a replacement probe, see section 11. Probe Replacement page 45-46 for two point temperature calibration. The built-in temperature sensor included in the probe is factory calibrated, and does not require two point calibration.

Use a temperature standard in the solution with your probe. Compare the value to a known standard or from the value of an NIST thermometer, to check if temperature calibration is needed.

1-point temperature calibration

1. Connect the probe as shown on page 7. The ATC annunciator will appear in the lower right-hand side of the LCD.
2. Press the **MODE** key to select temperature mode (**Temp**).

See Figure **A**

3. Press the **CAL/MEAS** key to enter calibration mode, the CAL indicator will flash in the upper right corner of the display. The primary display shows the measured conductivity or TDS value and the secondary display shows the temperature.

See Figure **B**

4. Dip the probe into a solution of known temperature (i.e. a temperature bath). Allow some time for the temperature probe to stabilize.
5. Scroll up or down with the **MI/▲** or **MR/▼** keys to set the correct temperature value (i.e. the temperature of the temperature bath). You can adjust the reading in increments of 0.1°C. Note that the current input reading can only vary $\pm 5^\circ\text{C}$ from the reading originally displayed on the meter.
6. Once you have selected the correct temperature, press the **ENTER** key. The meter returns to measurement mode.

See Figure **C**

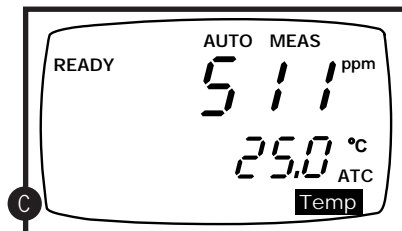
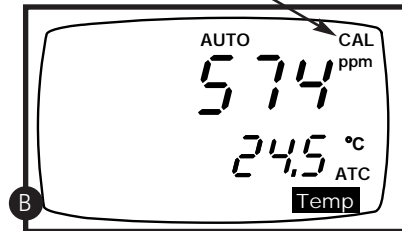
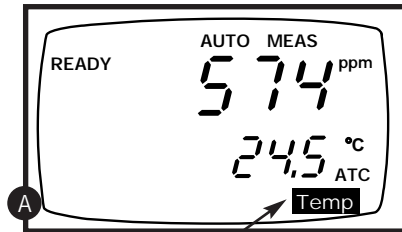

4.6 Errors in Calibration

When an error occurs during the calibration procedure, the display shows “ERR.”

See Figure **A**

For conductivity and TDS measurements, the display shows “ERR” when you try to change the slope by more than $\pm 20\%$. “ERR” displayed warns you of improper probe use, a bad calibration solution, or bad calibration technique.

For temperature calibration, the “ERR” displays once the calibrated value input exceeds the initial display value by $\pm 5^\circ\text{C}$.

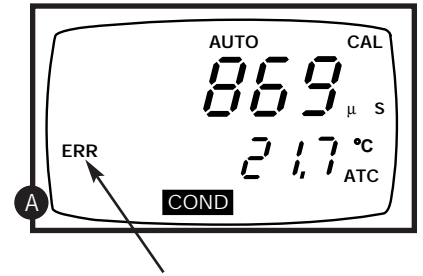

5. Measurement

This meter is capable of taking measurements with automatic or manual temperature compensation. Automatic temperature compensation only occurs when the temperature sensor is plugged into the meter. If there is no temperature sensor plugged into the meter the default temperature is automatically 25°C. You can manually set the temperature to match your working conditions using a separate thermometer. The probe included with your meter has a built-in temperature sensor

5.1 Automatic Temperature Compensation

1. **Switch on the meter, if necessary.** The **MEAS** annunciator together with the auto-ranging annunciator (**AUTO**) displays on the top center of the LCD.

For automatic temperature compensation (ATC) simply plug the temperature probe into the meter (see page 7). The **ATC** indicator will show on the LCD.

See figure **A**

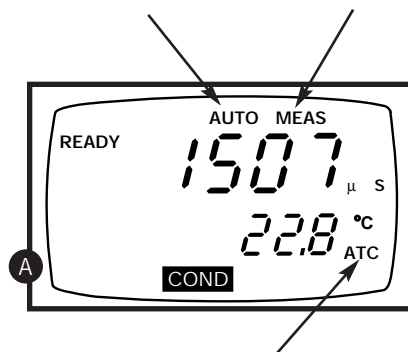

5.2 Manual Temperature Compensation

1. Turn the meter on. Press **MODE** to select temperature mode. Make sure the temperature sensor is unplugged.

See figure **B**

2. Press the **CAL/MEAS** key to enter calibration mode. The **CAL** indicator will appear above the primary display. The primary display shows the measured conductivity (or TDS) value and the secondary display shows the temperature.

See figure **C**

3. Check the temperature of your sample using an accurate thermometer.
4. Press **MI/▲** or **MR/▼** to set the temperature to the measured value.
5. Press **ENTER** to confirm the selected temperature.
6. Press **CAL/MEAS** to return to the measurement mode. Press **MODE** to select desired measurement mode (**COND** or **TDS** depending on model)

See figure **D**

The meter is now prepared for temperature compensation without the temperature probe.

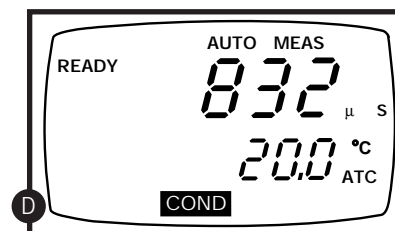
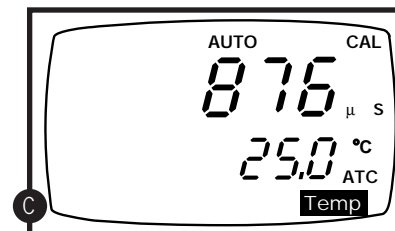
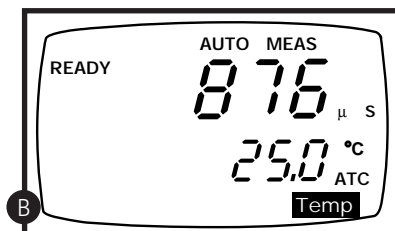

5.3 Taking Measurements

If your meter is set for **READY** mode operation, the **READY** indicator appears on the display when the reading stabilizes. The **READY** indicator shows only when the readings stabilize within a range of ± 1 digit per 15 seconds. The reading holds until the measured value exceeds the tolerance of ± 1 digit, then the **READY** annunciator turns off.

If your meter is set for continuous mode operation the **READY** annunciator will not appear.

NOTE: The **READY** mode is the default mode of operation. You can verify or change this through the **SETUP** mode Program2, P2.0, see page 28 for instructions.

To take readings:

1. Rinse the probe with deionized or distilled water before use to remove any impurities adhering to the probe body. Shake or air dry.
2. Switch on the meter. The **MEAS** annunciator along with the **AUTO** annunciator appears on the top center of the LCD. The **ATC** indicator appears in the lower right hand corner to indicate Automatic Temperature Compensation (See page 19 for setting Manual Temperature Compensation).

See Figure **A**

Note: For model WD-35607-20 press **MODE** to select conductivity or TDS measurement modes.

See figures **B** and **C**

3. Dip the probe into the sample.

NOTE: When dipping the probe into the sample, the tip of the probe must be completely immersed into the sample. Stir the probe gently in the sample to create a homogenous sample. *Be sure to tap probe to remove air bubbles. Air bubbles will cause errors in the reading.*

4. Allow time for the reading to stabilize. Note the reading on the display. When the reading is stable, the **READY** annunciator appears.

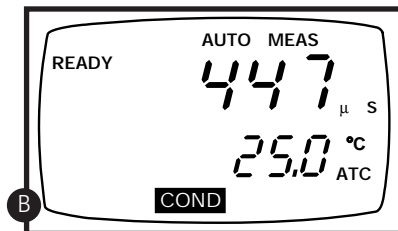
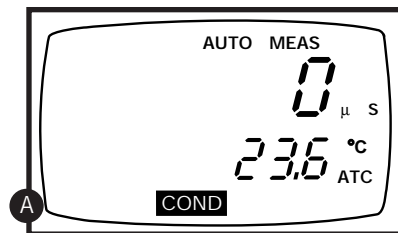

Conductivity measurement mode display

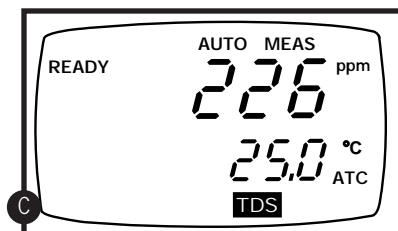

TDS measurement mode display

5.3 Using Manual Ranging Function

The manual ranging function will only work in the conductivity measurement mode. This function will not work in the TDS mode (“**ERR**” will flash on the display). This function selects the measuring range for conductivity measurement (0.00-19.99 μ S; 0.0-199.9 μ S; 0-1999 μ S; 0.00-19.99 mS; or 0.0-199.9 mS)

1. To select the desired conductivity measuring range, press the **RANGE** key while in conductivity measurement mode. The first range (0.00-19.99 μ S) will appear on the display. Press **RANGE** again (if needed) until desired range is selected. “**AUTO**” indicator disappears on the display.

See Figure **A**

2. To reselect the Auto-ranging function, press **RANGE** again until the “**AUTO**” indicator appears on the display.

See Figure **B**

NOTE: If the conductivity solution you are measuring is higher than the range selected “**Or**” will appear on the primary display. Press **RANGE** until the correct range is selected.

See Figure **C**

IMPORTANT: The meter resets to the Auto-ranging function once it is turned off. You will have reset the manual ranging function each time you turn the meter off.

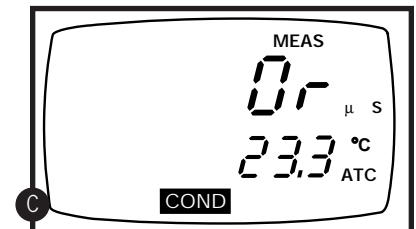
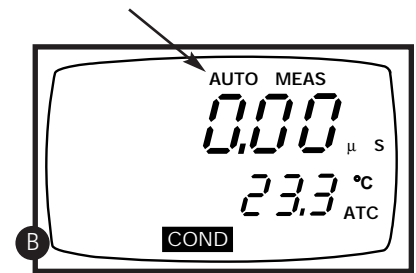
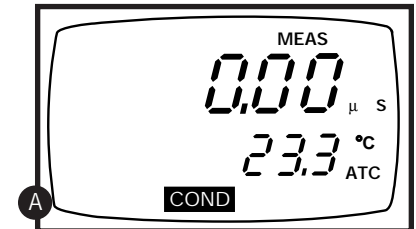

6. HOLD function

This feature lets you freeze the value of the conductivity or TDS (WD-35607-20 only) and temperature readings for a delayed observation. **HOLD** can be used any time when in **MEAS** mode.

1. To hold a measurement, press the **HOLD** key while in measurement mode. "HOLD" will appear on the display.

See Figure A

2. To release the held value, press **HOLD** again. Continue to take measurements.

NOTE: This meter will hold a reading for up to 20 minutes, because it features automatic shutoff after 20 minutes to conserve batteries.

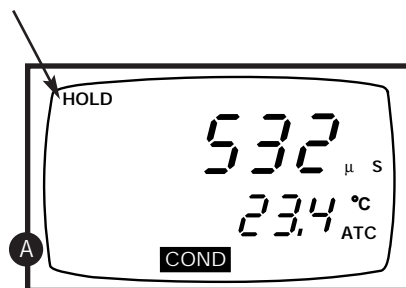

7. Memory and data input functions

7.1 Memory Input

Data is stored in sets:

- conductivity (μS or mS) and temperature
- TDS (ppm or ppt and mg/l or g/l) and temperature (WD-35607-20)

This meter can store up to 16 sets of data in any combination of values—conductivity or TDS (depending upon model). For example you can store 7 μS , 5 ppm, and 4 mg/l values. The meter uses the last-in-first-out (**LIFO**) method of memory management throughout each measurement mode. For example a conductivity reading can replace a TDS reading in memory. Readings put into memory are numbered with numeric (0-9) and alphabetical references (A-F) in the lower left-hand corner of the display.

1. **During any measurement function (MEAS)**, press the **MI/▲** key to input any data into the memory
2. **MEM and memory reference (0-9 or A-F) will flash**, for a few seconds on the display. The meter stays in measurement mode.

See Figure A

3. **If the memory is full, the first value stored in any measuring mode will be erased to create space for the new value.**

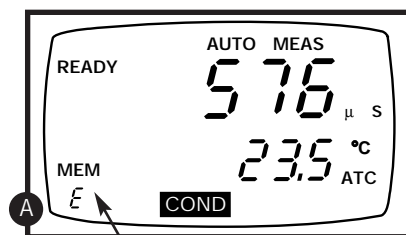

7.2 Memory Recall

This function recalls the previous readings stored in the memory. You can only access **MR/▼** in the **MEAS** mode. In conductivity mode, **MR/▼** recalls all stored conductivity values regardless of the measuring unit (μS or mS); in TDS mode, **MR/▼** recalls all stored TDS values regardless of the measuring unit (ppm or ppt and mg/l or g/l).

1. **Set the mode** to the parameter that you wish to recall (conductivity or TDS).
2. **Press the MR/▼ key once** to recall the last reading stored. **MEM and memory reference (0-9 or A-F) will flash** on the display.

See Figure A

3. **Press the MR/▼ key again** to recall the next to the last reading stored, and so on. When the first reading in memory is recalled and the **MR/▼** key is pressed again, "ERR" will flash signifying there are no more readings in memory for that measuring unit.

See Figure B

4. To prevent accidental memory clearing use the **SETUP** mode Program 1, P1.0 and turn the memory clear and reset **OFF**, see **SETUP** section page 26 for instructions.
5. To exit Memory Recall, press the **CAL/MEAS** key to return to the measurement mode.

NOTE: If you press the **MR/▼** and there is nothing stored in the memory "ERR" will flash.

IMPORTANT: Readings stored in memory are retained even if the unit is turned off. To erase all readings stored in Memory use the **SETUP** mode Program 1, P1.0 on page 26.

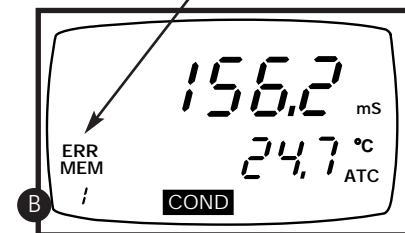
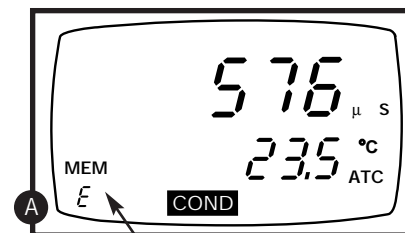

8. Setup Functions

The **SETUP** mode lets you customize the meters preferences and defaults through a series of advanced programs.

The **SETUP** mode has four main programs:

- **Stored Values:** clears or resets all stored values and displays calibration data.
- **Meter Function:** activates the “Ready” and “Auto-Off” functions, resets and erases all conductivity and TDS calibration data, selects normalization temperature, selects probe cell constant.
- **TDS Function:** selects conductivity to TDS conversion factor and TDS measuring units (models that measure TDS, WD-35607-20 only).
- **Communication Data:** sets up communication parameters for use with a printer or computer (model WD-35607-20 only).

8.1 SETUP Functions at a Glance

| Program | Function Keys | Activation | Options Settings | Default |
|---------|---------------------------------------|-------------|-------------------------------|---------------------|
| P1.0 | Memory Clear | MR/▲ & MI/▼ | ON, OFF | OFF |
| P1.1 | Temperature Coefficient Adjustment | MR/▲ & MI/▼ | Select value 0.0-10.0% per °C | factory set at 2.0% |
| P1.2 | Calibration Data Display | MR/▲ & MI/▼ | Indication only | – |
| P2.0 | READY | MR/▲ & MI/▼ | ON, OFF | ON |
| P2.1 | Auto Shut Off | MR/▲ & MI/▼ | ON, OFF | ON |
| P2.2 | Reset | MR/▲ & MI/▼ | ON, OFF | OFF |
| P2.3 | Temperature Normalization | MR/▲ & MI/▼ | 20.0 or 25.0°C | 25.0°C |
| P2.4 | Cell Constant | MR/▲ & MI/▼ | 0.1, 1.0 or 10 | – |
| P3.0 | Conductivity to TDS Conversion Factor | MR/▲ & MI/▼ | Select value 0.40 to 1.0 | 0.50 |
| P3.1 | TDS Units | MR/▲ & MI/▼ | ppm, ppt, mg/l or g/l | – |
| P4.0 | Baud Rate | MR/▲ & MI/▼ | 2.4, 4.8, 9.6, 19.2 Kbps | 9.6 Kbps |
| P4.1 | Parity | MR/▲ & MI/▼ | 1, 2, 0 | 2 |
| P4.2 | Stop Bit | MR/▲ & MI/▼ | 1, 2 | 2 |

8.2 General Instructions for All SETUP Programs

Please read the next four sections before operating **SETUP** functions. Refer to “SETUP functions at a glance” page 24 , for a quick review.

1. To enter **SETUP** mode, press **SETUP** key while in any measurement mode (μ S,mS, ppm, or ppt). The meter automatically enters Program 1, Option 0 (P1.0). You can only access **SETUP** through the measurement mode.
2. Press **ENTER** to advance through Programs.
3. Use **MI/▲ and MR/▼** keys to select options, if changes are required within a given Program.
4. Press **ENTER** to confirm the option in each program. The meter then automatically scrolls to the next program in sequence.
5. To exit the program, press **CAL/MEAS** and return to the measurement mode.

8.3 Program 1: Stored Values

Program 1 has three options.

P1.0 Memory Clear: Selecting ON clears all measurement values committed to memory (all 16 values despite the mode). Press **MI/▲** or **MR/▼** to select ON, if desired. Once memory is cleared, this program will return to the default setting OFF. Clear memory each time you need to store a new series of values, to avoid confusing the old memory values with the new ones. Press **ENTER**.

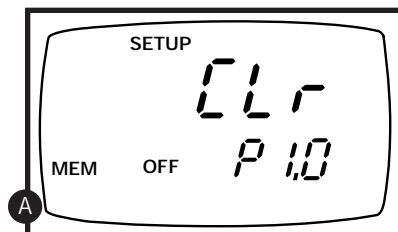

See Figure **A**

P1.1 Temperature Coefficient Adjustment: the temperature coefficient is the amount of change in conductivity per degree centigrade, and is expressed in percent per °C. Select the appropriate temperature coefficient, from 0.0 to 10.0% per °C, depending on the type of solution measured.*

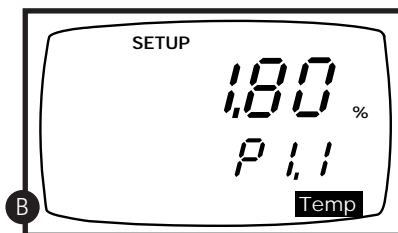

See Figure **B**

Press **MI/▲** or **MR/▼** to increase or decrease the temperature coefficient. Press **ENTER** when the value matches the temperature coefficient of your solution.

* If you do not know the temperature coefficient of your solution you can determine the correct value using the formula in Addendum 3 “Calculating Temperature Coefficients” on page 54.

P1.2 Calibration Data: Displays calibration for each of the five measurement ranges (one value in each range). The measuring range is indicated with a number displayed in the lower left corner (1-5). The display indicates the unit of measure μS , mS , ppm , ppt , mg/l or g/l and measurement mode (conductivity or TDS depending on model)

See Figure **A**

Press **MI/▲** or **MR/▼** to view the calibration data for the next range. For ranges that have not been calibrated the display will read “—”.

See Figure **B**

Note: Only one measuring parameter (μS , mS , ppm , ppt , mg/l or g/l) can be calibrated in each conductivity range. Each time a calibration is done for a particular range it replaces previous calibration data.

To exit the **SETUP** mode, press **CAL/MEAS**. Press **ENTER** to move to the next program in the **SETUP** mode (P2.0).

Note: If the “Conductivity to TDS conversion factor”, Program 3, P3.0, page 30 is changed, TDS calibration ranges will display “—”. Recalibrate the TDS ranges for maximum accuracy whenever the conductivity to TDS conversion factor is changed.

See Figure **C**

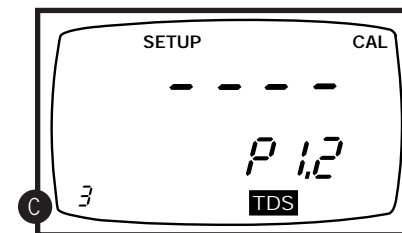
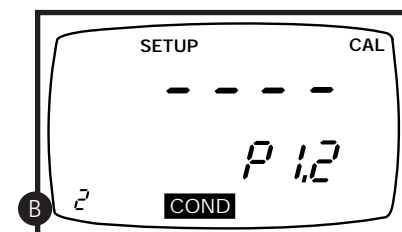
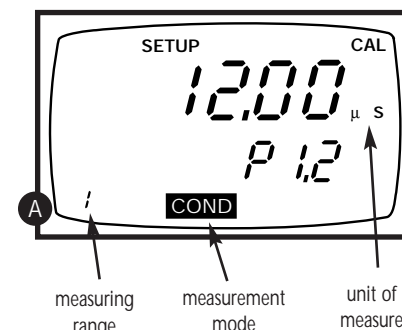

8.4 Program 2: Meter Function

Program 2 has five options that lets you check the electrode parameters for diagnostic purposes.

P2.0 READY selection: Use the **MI/▲** or **MR/▼** key to turn **ON** or **OFF** the **READY** option. The **READY** indicator shows only when the readings stabilize within a range of ± 1 digit per 15 seconds. The reading holds until the measured value exceeds the tolerance of ± 1 digit, then the **READY** annunciator turns off. The default setting is **ON**. Use **MI/▲** or **MR/▼** key to select **ON** or **OFF**. Press **ENTER** to confirm selection.

See Figure **A**

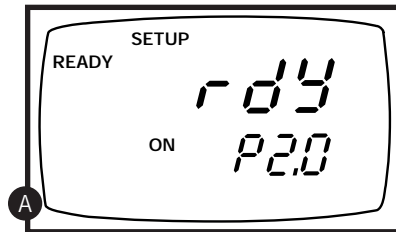

P2.1 Auto-Off: To conserve energy, this function automatically shuts off the meter within 20 minutes after the last key has been pressed. Default setting is **ON**. Use **MI/▲** or **MR/▼** key to select **ON** or **OFF**. Press **ENTER** to confirm selection.

See Figure **B**

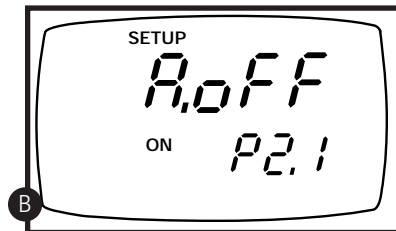

P2.2 Reset: Selecting **ON** resets the entire meter. The meter immediately switches off, and you must power **ON** before proceeding with any other functions. If reset is required, press **MI/▲** or **MR/▼** to select **ON** and then press **ENTER** to activate. Reset clears all calibration data for conductivity and TDS. Once memory is cleared, all settings will return to the default setting. Press **ENTER** to continue to the next Program, if **OFF** is selected.

See Figure **C**

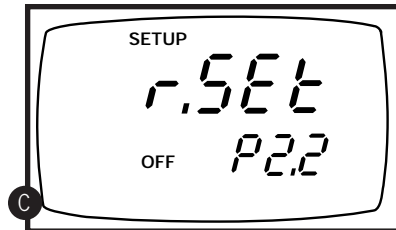

P2.3 Temperature Normalization: The conductivity of solution varies greatly with temperature. The meter's automatic temperature compensation (ATC) feature adjusts conductivity measurements to factor out fluctuations in the readings caused by temperature.

The meter readings are referenced to or normalized at a standard temperature: either 20° or 25°C. This feature lets you compare conductivity readings of various temperatures. Default setting is 25°C.

Press the **MI/▲** or **MR/▼** keys to toggle the temperature normalization setting to 20 or 25°C.

See Figure **D**

Press the **ENTER** key when you have made your selection. The meter automatically scrolls to Setup parameter 2.4. To exit the **SETUP** mode, press **CAL/MEAS**.

P2.4 Cell Constant: Select the nominal cell constant depending on the probe you use. The standard probe included with the meter has a nominal cell constant of 1.0. With this program, you can use an probe with $K=0.1$, for low conductivity measurements below 20 μS , or an probe with $K=10.0$, for high conductivity measurements above 20 mS .

Press the **MI/▲** or **MR/▼** keys to toggle between a cell constant of 1.0, 10.0, and 0.1.

See Figure **E**

P2.4 Press the **ENTER** key when you have made your selection. Model WD-35607-10 automatically returns to measurement mode. Model WD-35607-20 continue to Program P3.0.

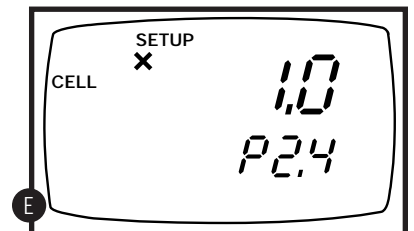
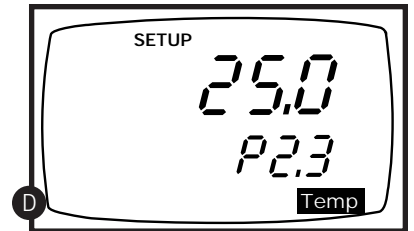

8.5 Program 3: TDS Function (WD-35607-20 only)

Program 3 has two options for customizing.

P3.0 Conductivity to TDS Conversion

factor: Press **MI/▲** or **MR/▼** to increase or decrease the conductivity to TDS conversion factor. You can adjust the value from 0.4 to 1.0. Values less than 0.4 or greater 1.0 will cause the “ERR” indicator to flash. The default setting is 0.5. Press the **ENTER** key to confirm your selection and move to the next program.

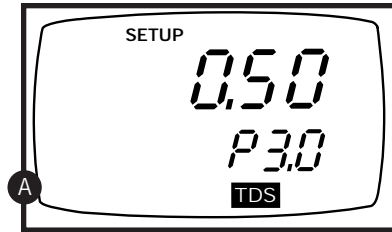

See Figure **A**

Note: The Conductivity to TDS Conversion Factor for a particular solution is a multiplication factor that relates the measurement of conductivity in $\mu\text{S}/\text{cm}$ (or mS/cm) to its equivalent reading in ppm (or ppt). This factor is unique for a specific solution. If you do not know the conversion factor for your solution see the table in Addendum 1, page 52. Many Conductivity Calibration Solutions will list conversion factors on their labels. For the highest accuracy in your specific sample solution, see the method and calculation given in Addendum 2, page 53.

P3.1 TDS Measuring Units: Use the **MI/▲** or **MR/▼** to select ppm (and ppt) or mg/l (and g/l). The default setting is ppm. Press **ENTER** to confirm selection.

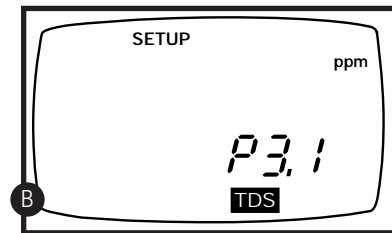

See Figure **B**

Model WD-35607-20 automatically continues to Program P4.0.

8.6 Program 4: Communication Set-Up (WD-35607-20 only)

Program 4 has three options that lets you set up the meter communication parameters when operating with either your optional printer or PC. Set these options to match your printer or PC requirements.

P4.0 Baud Rate: Press **MI/▲** or **MR/▼** to select a baud rate of 2.4, 4.8, 9.6, or 19.2 Kbps (2400, 48000, 9600, or 19200 bps). The default setting is 9.6 Kbps (9600 bps). Press **ENTER**.

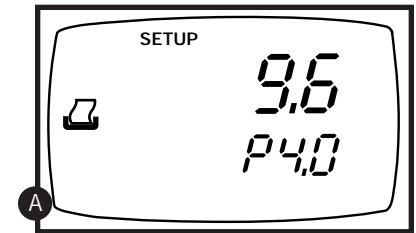

See Figure **A**

P4.1 Parity: Press **MI/▲** or **MR/▼** to select parity of 1, 2, or 0. Default setting is 2 (EVEN). Press **ENTER**.

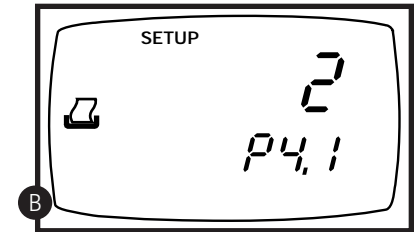

See Figure **B**

P4.2 Stop Bit: Press **MI/▲** or **MR/▼** to select the stop bit to be 1 or 2. Default setting is 2. Press **ENTER**.

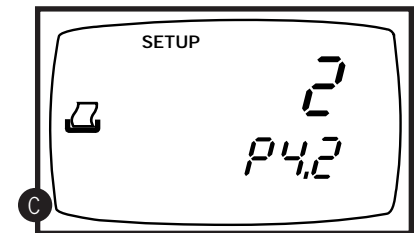

See Figure **C**

The meter automatically returns to measurement mode.

9. Optional Printer and RS-232 Output Setup

This section is for CON 200 model WD-35607-20 only (model with RS-232 capabilities). Meters with RS-232 provide an output for transmitting readings to a printer or computer. The data is supplied in ASCII format. ASCII format allows data to be imported into most popular software programs, and to most printers.

9.1 Using with OAKTON Printer WD-35622-00

See Printer manual for more details

1. Connect cable WD-35622-00 from printer to meter.
2. Configure printer for Portable Conductivity/TDS meter.
3. Press **PRINT** key ()

9.2 Using with a Non-OAKTON Printer

Minimum printer requirements to print data:

- A 9 pin RS-232 serial port on printer.
- Printer should have the option to receive 8 data bits; even (2), odd (1) or none (0) parity bits; and 1 or 2 stop bits.

NOTE: To print data, connect the meter directly to the printer. You do not need to connect the meter to the computer.

Connecting the cable to the meter

1. Carefully open the port cover located on the heel of the meter. Do not use excessive force.

See figure **A**

2. Noting the orientation of the RS-232 connector, plug the male connector into the RS-232 port on the meter.
3. Tighten the two screws on the sides of the male RS-232 connector.

NOTE: For the meter and printer to properly communicate and transfer data, the pin configurations on both units must match. To determine this, compare the pin configuration of your printer (see the printer manual) with the pin configuration of this meter (see figure below). Since there is no industry standard for the pin configuration on printers, you might need to configure the pins. Configuring the pins may require soldering. Also, jumper boxes and cable-making products are available from most computer stores.



The meter has a 9 pin female RS-232 connector with this configuration:

| <u>Pin Number</u> | <u>Description</u> |
|-------------------|----------------------|
| 1 | - |
| 2 | TXD (Transmit Data) |
| 3 | - |
| 4 | DSR (Data Set Ready) |
| 5 | GND (Ground) |
| 6 | - |
| 7 | CTS (Clear To Send) |
| 8 | - |
| 9 | - |

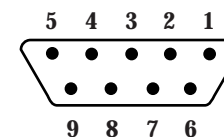

If the printer has a 25 pin connector, use a 25 pin to 9 pin converter. Use the following configuration:

| <u>Pin Number of meter</u> | <u>Pin number of printer</u> |
|----------------------------|------------------------------|
| 2 (TXD-Transmit Data) | 3 (RXD-Receive Data) |
| 4 (DSR-Data Set Ready) | 20 (DTR-Data Terminal Ready) |
| 5 (GND-Ground) | 7 (GND-Ground) |
| 7 (CTS-Clear to Send) | 4 (RTS-Request to Send) |

Preparing the printer

Set printer to match the meters RS-232 parameters as set in SETUP Program 4, P4.0, P4.1, and P4.2 on page 31 (consult the printer manual for specifications).

Printing data

Press the **PRINT** key () on the meter to send data to the printer .

See figure **B**

“Or” on the LCD, printer, or computer screen as conductivity value means over range. The conductivity probe might be disconnected. Check probe connections and mode setting (conductivity or TDS).

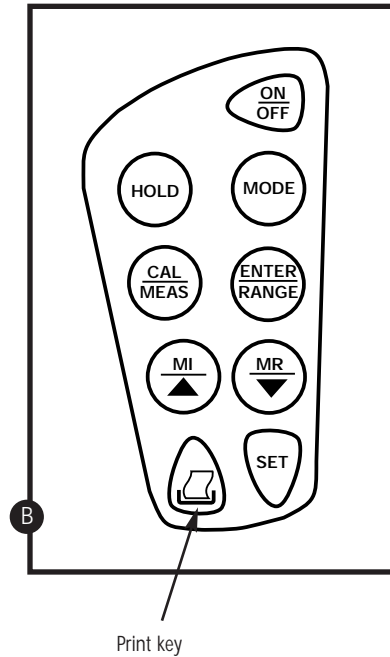

9.3 Using with a printer to download stored memory

The meter will only print measurements that are on the display, either “live” or stored measurements maximum 16 values. To print stored measurements, first recall measurements from memory. To recall a measurement from memory, the meter must be in the **MEAS** mode (not **CAL**), and in the the same measurement mode it was in when the measurement was stored.

Examples: To recall a measurement stored as a conductivity value, the meter must be in the **MEAS** conductivity (**COND**) mode. To recall a measurement stored as a TDS value, the meter must be in the **MEAS** TDS mode.

See figure **A**

1. To download stored readings in memory to a printer, set up the meter and printer described on pages 32-34.
2. While the meter is in the **MEAS** mode, press **MR/▼** to display the last measurement value stored in memory.
3. Press **PRINT** key () on the meter to print the last value.
4. Press **MR/▼** again to recall the second-to-last measured value stored in memory.
5. Press **PRINT** to print the second-to-last value.
6. Repeat steps 4 and 5 above until all stored values are printed.
7. To print other measurement values stored in memory, press **CAL/MEAS** to return to measurement mode.
8. Select the next measurement mode (**COND** or **TDS**) for the values stored in memory
9. Repeat step 2 through 6 above until all values stored in the same measurement mode are printed.
10. Repeat steps 7 through 9 above until all stored values are printed.

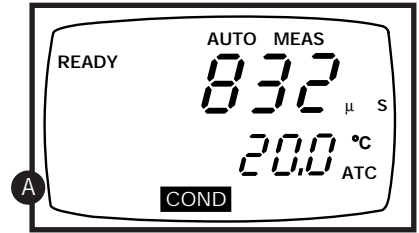

9.4 Using with a Computer and the OAKTON Datalog Assist Software

Minimum Computer Requirements to run software:

- IBM PC/XT/AT or 100% compatible (DOS 3.0 or later)
- 640K RAM memory
- Monitor
- RS-232 serial port
- 3½" floppy disk drive

The OAKTON Datalog Assist Software is a very basic data acquisition software that provides a convenient way to capture data for future analysis. Data is stored in the ASCII format. This allows the data to be transferred to a variety of popular software programs. The disk includes three programs:

- README BAT:** simply type README to see the content of the README.DOC file.
- ONDATA EXE:** the data acquisition software.
- README DOC:** is a program that describes what the ONDATA and DEMO programs do.

To see this list, type "DIR" at the DOS prompt for directory. Data files will also appear on the directory as they are created.

Connecting the cable to the meter

1. Carefully open the port cover located on the heel of the meter. Do not use excessive force.

See figure **B**

2. Noting the orientation of the RS-232 connector, plug the male connector into the RS-232 port on the meter.
3. Tighten the two screws on the sides of the male RS-232 connector.



Connecting the cable to the computer

1. Locate the port on the computer.
2. Noting the orientation of the RS-232 connector, plug the male connector into the RS-232 port on the computer.
3. Tighten the two screws on the sides of the male RS-232 connector.
4. If the computer has a 25 pin connector, you will need a 25 pin to 9 pin adapter.

Loading the OAKTON Datalog Assist Software

1. Turn on computer.
2. Insert the 3 ½" disk provided with the meter into the floppy disk drive on the computer. See the computer instruction manual to locate the drive. Be sure "write protect" on disk is off or unlocked.
3. To boot the software

from DOS, type "ONDATA", the name of the data acquisition program. You can also type "DIR" at the DOS prompt. "DIR" will show you the directory of the programs on the disk. To enter the data acquisition program, type "ONDATA" at the DOS prompt. At the A:\ type "RUN ONDATA"

from Windows Program Manager, select "RUN" and enter the file name "ONDATA".

from Windows 95, taskbar select "START" and "RUN". Click the "BROWSE" button. Find and select the "ONDATA" file on your A:\ drive.

Setting the communication parameters

The meter is capable of different communication configurations for baud rate, parity bits and stop bits. The values chosen for these parameters for the meter must match those chosen for the computer.

After entering **ONDATA** as stated on page 37, a blank screen appears where the measurement data will go. The following screen will appear:

```
OAKTON DATA LOG ASSIST . . . . . COMMUNICATIONS PROGRAM VER 1.1

RECEIVING OAKDATA          ESC-EXIT      F5-SETUP      F1-HELP
```

1. Push **F1** to enter the **HELP** program. The first screen of **HELP** explains the function keys used in the **SETUP** program.

```
OAKTON DATA LOG ASSIST . . . . . COMMUNICATIONS PROGRAM VER 1.1

HELP SCREEN
HELP                :F1
EXIT FROM MAIN PROGRAM :ESC

SETUP KEYS
-----
SETUP                :F5
SAVE & EXIT FROM SETUP :F3
TO CHANGE VALUE      :+
SWITCH OPTION        :TAB

ESC-EXIT FROM HELP... PGDOWN/PGUP

RECEIVING OAKDATA          ESC-EXIT      F5-SETUP      F1-HELP
```

Push either “Page Up” or “Page Down” to advance to the second screen of **HELP**. This screen indicates the proper file name extensions that you must use when naming files (done in the **SETUP** program) that will be imported into other software programs. No extension is needed if you are not importing the data into another program.

```
OAKTON DATA LOG ASSIST . . . . . COMMUNICATIONS PROGRAM VER 1.1

HELP SCREEN
FILE NAME LENGTH
-----
MAXIMUM LENGTH OF FILE NAME IS 12 CHARACTERS

FILE NAME EXTENSION FORMAT
-----
LOTUS® 123®       :USE FILE NAME WITH [.PRN] EXTENSION
EXCEL®            :USE FILE NAME WITH [.CSV] EXTENSION
WORDSTAR®        :USE FILE NAME WITH [.DOC] EXTENSION
NORTON EDITOR®   :USE FILE NAME WITH [.PRN] EXTENSION

NOTE: THIS PROGRAM USES COMPUTER DATE AND TIME. PLEASE
SET YOUR COMPUTER DATE AND TIME BEFORE EXECUTING
THIS PROGRAM

ESC-EXIT FROM HELP... PGDOWN/PGUP

RECEIVING OAKDATA          ESC-EXIT      F5-SETUP      F1-HELP
```

2. Push **ESC** to exit the **HELP** program.

3. Push **F5** to enter the **SETUP** program. You will see the following:

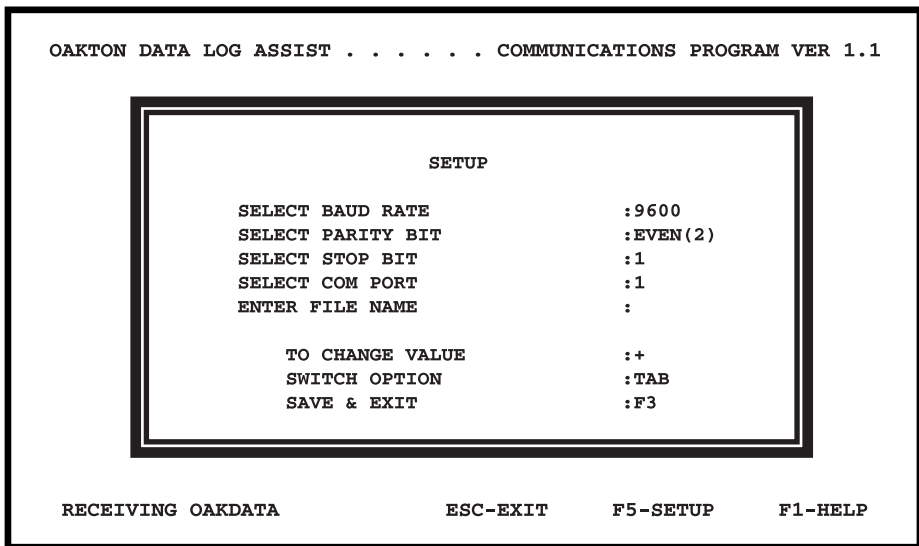

You may select from the following settings:

- Baud rate** : 2400, 4800, 9600, 19200
- Parity bit** : NONE (0), ODD (1), EVEN (2)
- Stop bit** : 1, 2
- Com port** : 1, 2

(the Com port is communication port that the cable is hooked to on the computer)

4. Set each parameter to the same value as the value chosen in the **SETUP** program of the meter. To set these parameters in the meter, see **SETUP** mode, Program 4 on page 31 of this manual for complete instructions. Use the “+” key to toggle between the choices for each parameter.
5. After choosing a value for a parameter, push the “**TAB**” key to move to the next line. Continue until all parameters (baud rate, parity bit, stop bit and com port) are chosen. Push “**TAB**” to move to the next line, “**Enter file name.**”
6. Enter a file name. If the data will be imported into another software program, use the proper file extension as shown on the second screen of **HELP**. The entire file name, including the period and three-letter extension (for example “.PRN” for Lotus 1-2-3), can be maximum of 12 characters. If the data will not be imported into another software program, then a file extension is not required. Push “**enter**” to enter the file name.
7. Push **F3** to save the parameters and the file name, and to exit the **SETUP** program. The file name will be listed in the directory.
IMPORTANT: If you exit this program by pressing **Esc** instead of **F3**, all information just selected will be lost. All parameters and the file name will convert back to those that had been shown when you first entered the **SETUP** program.
8. No matter which key you pressed to exit the **SETUP** program (either **F3** or **ESC**), the **ONDATA** screen will now appear.

9.5 Sending data to the computer

1. Press the **PRINT** key () on the meter to send data to the computer.

See figure **A**

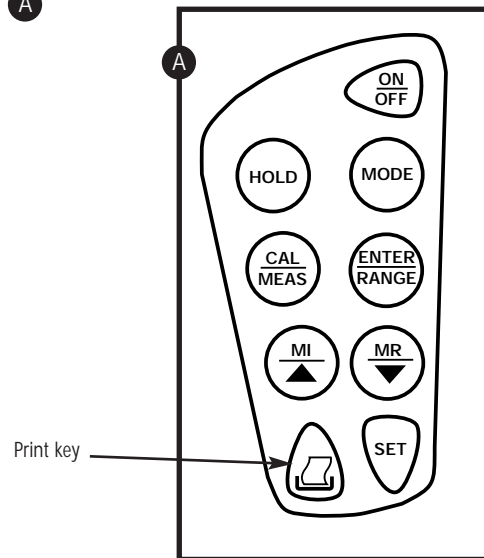

2. The data appears on the **ONDATA** computer screen as follows:

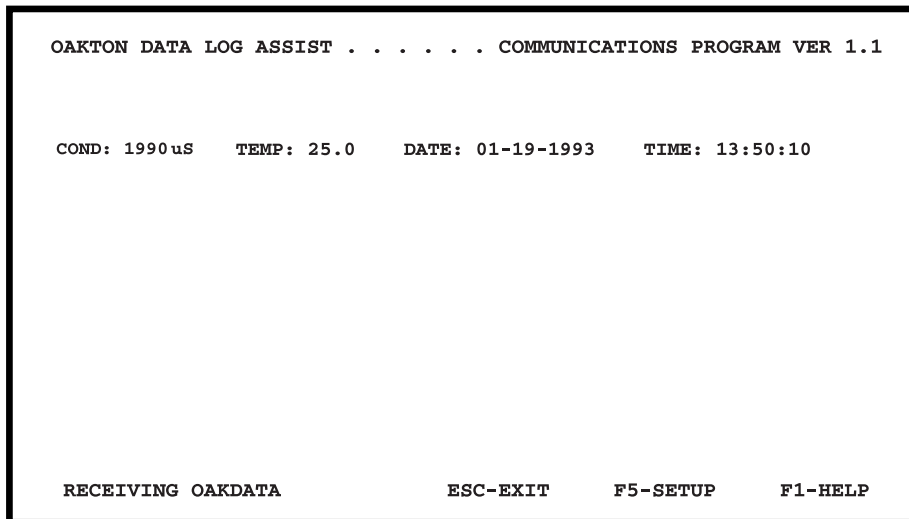

Note: If your meter is set for TDS measurement the screen will show “TDS” instead of “COND”.

3. Continue to push **PRINT** on the meter to send data to the computer.
4. When all data has been collected, push **ESC** to quit the **ONDATA** program.



9.6 Using with a Computer and the OAKTON Datalog Assist Software to Download Stored Memory

The meter will only send measurements to the computer that are on the display, either “live” or stored measurements. To download stored measurements, first recall measurements from memory. To recall a measurement from memory, the meter must be in the **MEAS** mode (not **CAL**), and in the same measurement mode it was in when the measurement was stored. Date and time of measurement are not stored. When downloading stored measurements, the date and time on screen will be the current date and time.

EXAMPLES: To recall a measurement stored as a conductivity value, the meter must be in the **MEAS** conductivity (**COND**) mode. To recall a measurement stored as a TDS value, the meter must be in the **MEAS** TDS mode.

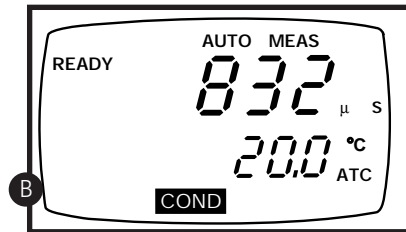
See Figure **B**



1. To download stored readings in memory to a computer, set up the meter and computer as described on pages 31-36 of this manual.
2. While the meter is in the **MEAS** mode, press **MR** to display the last measured value stored in memory.
3. Press **PRINT** key () on the meter to send the last value to the computer.
4. Press **MR** again to recall the second-to-last value.
5. Press **PRINT** key () on the meter to send the second-to-last value to the computer.
6. Repeat steps 4 and 5 above until all measurement values stored are sent to the computer.
7. To send other measurement values stored in memory to the computer, press **CAL/MEAS** to return to the measurement mode.
8. Select the next measurement mode (**COND** or **TDS**) for the measurement values stored in memory.
9. Repeat steps 2 through 5 above until all values stored in the same measurement mode are downloaded to the computer.
10. Repeat steps 7 through 9 above until all measurement values stored in memory are downloaded.

9.7 Viewing a Data File

1. To view a data file, type “**type**”, followed by a space, and the file name at the DOS prompt. The contents of the file will appear, but you will not be able to change the data.
2. To view a data file and change any information in the file, type “**edit**”, followed by a space, and the file name at the DOS prompt. The contents of the file will appear. Use the arrow keys on the computer to move the cursor around.
3. To quit, press **ESC**. If you made change to the file, the computer will ask if you want to save the change. Press **Y** for yes and **N** for no.

9.8 Printing Errors

If the LCD shows “**ERR**”, the print annunciator blinks or the meter prints or downloads garbled data, or prints or downloads nothing; the printer or computer might not be connected properly; check cable connections. Also, the dip switch setting could be set wrong. Check dip switches for baud rate, data bits, and parity.

10. Probe Care and Maintenance

Keep the conductivity probe clean. Rinse the probe twice, and gently swirl it while you take readings. For best accuracy, soak a dry probe for at least 5 to 10 minutes or longer before calibration. Rinse the probe with deionized or tap water before storing. Never scratch the platinum portions with a hard substance. Do not strike the probe against any hard surface.

Do not make continuous contact with your solutions. Readings will rise over a period of time while you soak your probe

Do not immerse the probe in oily solutions. Clean the electrode thoroughly by stirring it in a mild detergent bath. Wipe the probe with a soft tissue paper. Rinse thoroughly in tap water and then in deionized water. Recalibrate the meter after cleaning the probe.

11. Probe Replacement

Your meter and probe have been factory calibrated to each other for maximum accuracy. If you notice a reduction in accuracy after replacing your probe, perform a zero calibration and two-point temperature calibration.

11.1 Zero calibration

NOTE: The conductivity probe must be clean and air dried for zero adjustment.

1. **Connect the BNC and phone jacks of the probe to the conductivity meter.**
2. **Turn the meter off.**
3. **Press CAL/MEAS and then press ON/OFF, while still holding down CAL/MEAS. Release ON/OFF before releasing CAL/MEAS. The display blinks “ECO.3”.**

See figure **A**

4. **Press ENTER three times.** The LCD shows r1.0 on the secondary display and 0.00 μ S on the primary display. The r1.0 indicates that you are in the first, or lowest range.

See figure **B**

5. **Press ENTER to calibrate the range or CAL/MEAS to skip calibration of the range.**
6. **At each of the measurement ranges, press ENTER if zero adjustment is required.** Once ENTER is pressed, a value displays on the LCD. Wait until the value is low and as stable as it can be before pressing ENTER again. This step adjusts zero for the selected range.

See figure **C**

7. **Repeat step 6 for the other ranges if necessary.** If you do not want to repeat this step, press CAL/MEAS to skip to the next range.

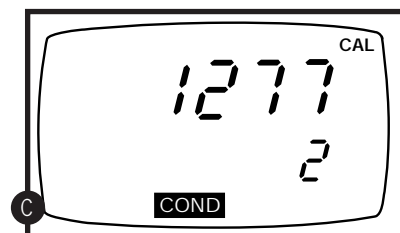
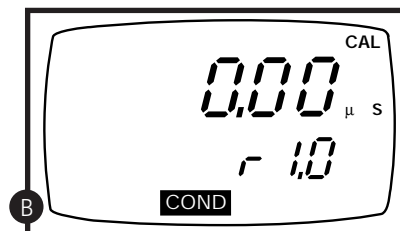
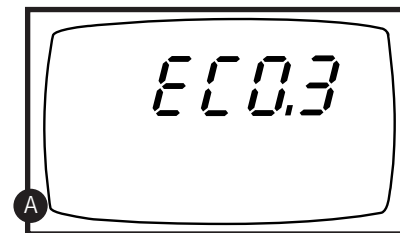

11.2 Two point temperature calibration

After zero calibration, the meter proceeds to program 6.0, for temperature calibration of the probe. The temperature in °C shows in the primary display and "r6.0" shows in the secondary display.

See figure **A**

1. **Press CAL/MEAS until the meter automatically switches off to skip this section of the calibration.** Do NOT press ENTER unless you have completed the steps below. Pressing ENTER replaces current temperature calibration data and causes measurement errors.

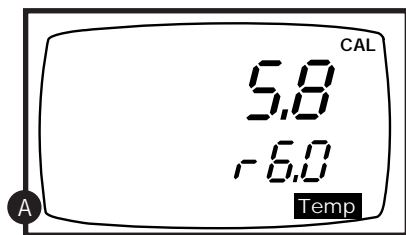

2. **Prepare two constant temperature baths**, one at a temperature below 5°C (low temperature bath) and the other at between 50°C to 60°C (high temperature bath).

3. **Dip the probe into the low temperature bath.** Allow 5 to 10 minutes for the probe to stabilize.

4. **Press the ▲ or ▼ keys** to fine tune temperature reading to match bath temperature.

5. **Press ENTER.** The screen now shows the A-to-D count corresponding to your low temperature calibration point. This is a five digit number with the first digit appearing in the secondary display and the rest of the digits in the primary display. In our example at right, the A-to-D count is 13490.

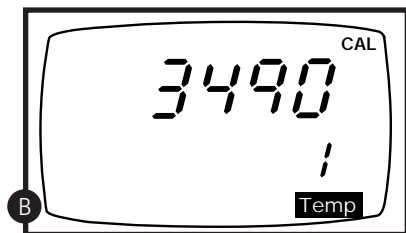

See figure **B**

6. **Let the count stabilize, then press ENTER again.** This confirms your low temperature calibration point, and moves you into high temperature calibration ("r6.1) If you do not want to confirm your calibration, press CAL/MEAS.

7. **Repeat steps 4-6 with high temperature bath.**

NOTE: To exit from the hardware calibration at any point, press ON/OFF to switch off the meter and abort the calibration. Only calibration points that have been confirmed by pressing ENTER will be retained.

12. Troubleshooting

| Problem | Cause | Solution |
|--|--|--|
| Power on but no display | <ul style="list-style-type: none"> a) Batteries not in place. b) Batteries not in correct polarity (+ and -). c) Weak batteries. | <ul style="list-style-type: none"> a) Check that batteries are in place and making good contact. b) Re-insert batteries with correct polarity. c) Replace batteries or attach optional AC adapter. |
| Unstable readings | <ul style="list-style-type: none"> a) Air bubbles in probe. b) Dirty probe. c) Low conductivity. d) Probe not deep enough in sample. e) External noise pickup or induction caused by nearby electric motor. f) Broken probe. | <ul style="list-style-type: none"> a) Tap probe to remove bubbles. b) Clean the probe and recalibrate. c) Avoid atmospheric contact with solution. d) Make sure sample entirely covers the probe sensors. e) Move or switch off interfering motor (or noise). f) Replace probe. See page 50. |
| Not able to calibrate | <ul style="list-style-type: none"> a) Dirty/Oily probe. b) Incorrect TDS factor in TDS mode (TDS models). c) Incorrect probe cell constant. | <ul style="list-style-type: none"> a) Clean probe. See "Probe Care & Maintenance", page 44. b) Set proper TDS factor prior calibration, see SETUP section Program3, P3.0 on page 30 for instructions. c) Replace probe or set meter to correct probe cell constant see SETUP section Program 2 P2.4 on page 29. |
| "Or" on LCD, printer or computer screen | <ul style="list-style-type: none"> a) Probe is shorted. b) Conductivity of solution is too high for probe. | <ul style="list-style-type: none"> a) Check or replace probe (see page 50) b) Choose a conductivity probe with a higher cell constant (K) see page 50 or use a different solution. |

13. Error Messages

| LCD Display | Indicates | Cause | Solution |
|---|--|--|---|
| Err annunciator | Unrecognized input from keypad | Wrong input in selected mode. | Release key. Select valid operations depending on mode. |
| CAL & Err annunciators blink | Calibration error | Wrong value input at calibration. Dirty probe. | Check your calibration input value, clean probe. See Calibration sections or Probe Maintenance section. |
| Battery indicator blinks | Low battery level | Need new batteries or battery connection is bad | Clean battery contacts. Replace batteries with fresh ones, noting polarity |
| Err annunciator & printer indicator blinks | Unable to print or send data to computer | Printer/computer is off, cable is unplugged or . cable is faulty | Turn printer/computer on, check cable connections, or check printer/computer settings on both the meter and receiving device. |
| Err. 1 (in primary display) | Memory write error | Instrument too old (>10 years). Hardware failure | Turn meter on and off again. If message persists, return unit* |
| Err. 2 (in primary display) | Memory checksum error | Hardware failure. | Turn meter on and off again. If message persists, return unit* |
| Err. 3 (in primary display) | ACD converter error | Hardware failure. | Turn meter on and off again. If message persists, return unit* |
| Err. 4 (in primary display) | Keypad error | Fault in keypad | Turn meter on and off again. If message persists, return unit* |

* See "Warranty" and "Return of Items" on page 59

If an error message appears in the primary display (the upper row of larger digits), switching off the meter and switching it on again may eliminate the error message.

See figure **A**

If error persists, or the meter shows incorrect values, return the meter.

For a complete diagram of the display, see page 4.

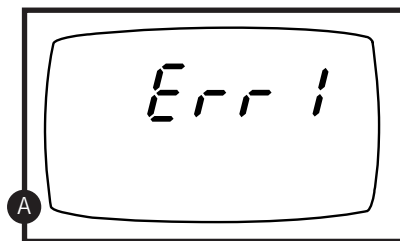

ERR 1 in primary display

14. Specifications

| Mode | Conductivity | TDS | Temperature |
|--------------------|---|--|---|
| Range | 0.00 to 19.99 μ S 0.0 to 199.9 μ S 0 to 1999 μ S 0.00 to 19.99 mS 0.0 to 199.9 mS | 0.00 to 9.99 ppm 10.0 to 99.9 ppm 100 to 999 ppm 1.00 to 9.99 ppt 10.0 to 99.9 ppt 100 to 200 ppt | 0.0 to 80.0°C (with epoxy platinum probe) 0.0 to 100.0°C (with glass/platinum probe) |
| Resolution | 0.01 μ S 0.1 μ S 1 μ S 0.01 mS 0.1 mS | 0.01 ppm 0.1 ppm 1 ppm 0.01 ppt 0.1 ppt 1 ppt | 0.1°C |
| Accuracy | \pm 1% Full Scale | \pm 1% Full Scale | \pm 0.5°C |
| Calibration | Up to five points (one point per range) | Up to five points (one point per range) | Offset in 0.1° increments |

Temperature compensation: automatic (ATC) or manual from 0 to 100°C

Temperature Coefficient Adjustment: 0.0 to 10.0% per °C

Cell constant: 1 with probe supplied. Cell constant of 0.1 is best for very low ranges (<10 μ S) and a cell constant pf 10 is best for higher ranges (100 mS).

Operating temperature: 0 to 50°C

RS-232 Communication (models WD-35607-20 only): 9 pin female, select baud rates 2.4, 4.8, 9.6, and 19.2 kbps (2400, 4800, 9600, 19200 bps); stop bit and parity

Power: four 1.5 V AAA batteries (included) or AC adapter (optional; order separately on page 50)

Battery life: > 60 hours

Dimensions:

Meter: 7.5"L x 3.5"W x 1.75"H

(19.1 cm x 8.9 cm x 4.5 cm)

Boxed: 9.2"L x 8.5"W x 2.75"H

(23.3 cm x 21.6 cm x 7 cm)

Probe: 5.0"L x 0.5"dia with 2.5 ft cable

(100 mm L x 12 mm dia with 0.9 m cable)

Shipping weight: 2 lbs (0.9 kg)

15. Accessories

Replacement probes and accessories

WD-35615-09 RS-232/Printer cable, 9- pin male for units with RS-232 printer output.

WD-35615-07 AC adapter, 9 VDC to 110 VAC.

WD-35615-08 AC adapter, 9 VDC to 220 VAC.

WD-35615-75 Belt loop portable meter carrying case. Soft case with clear plastic front panel protects your meter while allowing you to take measurements. Top and side openings let probe and probe connections remain accessible.

WD-35607-60 Conductivity/TDS Calibration Kit (meter not included).

Includes 60 mL of four calibration solutions (84 μ S, 447 μ S, 15,000 μ S, and 80 mS), a squirt bottle with 120 mL deionized water, and a 60-ml sample bottle all secured in a hard carrying case.

WD-35615-06 Replacement electrode holder.

WD-35607-50 Replacement conductivity cell. Epoxy body/platinum sensor with built-in temperature sensor. K = 1.0.

WD-35607-52 Portable conductivity cell. Glass body/platinum sensor with built-in temperature sensor. K = 1.0.

WD-35607-51 Portable conductivity cell. Epoxy body/platinum sensor with built-in temperature sensor. K = 10.

WD-35607-53 Portable conductivity cell. Glass body/platinum sensor with built-in temperature sensor. K = 10.

WD-35607-55 Portable conductivity cell. Epoxy body/platinum sensor with built-in temperature sensor. K = 0.1.

WD-35607-56 Portable conductivity cell. Glass body/platinum sensor with built-in temperature sensor. K = 0.1.

WD-35607-54 Flow-through conductivity cell. Glass body/platinum sensor with built-in temperature sensor. K = 1.0. Use for continuous in-line measurement for flows up to 1 gal/minute and pressures up to 80 psi.

OAKTON conductivity calibration solutions

Conductivity solutions have $\pm 1\%$ accuracy at 25°C. Shpg wt 1.1 lb (510 g). See Addendum 1, page 51 for TDS values for the solutions below.

WD-00653-23 23 μ S calibration solution, 1 pint

WD-00653-16 84 μ S calibration solution, 1 pint

WD-00653-47 447 μ S calibration solution, 1 pint

OAKTON conductivity calibration solutions (continued from page 50)

WD-00653-18 1413 μ S calibration solution, 1 pint

WD-00653-15 1500 μ S calibration solution, 1 pint

WD-00653-27 2070 μ S calibration solution, 1 pint

WD-00653-20 2764 μ S calibration solution, 1 pint

WD-00653-89 8974 μ S calibration solution, 1 pint

WD-00060-10 12880 μ S calibration solution, 1 pint

WD-00653-50 15,000 μ S calibration solution, 1 pint

WD-00653-32 80 mS calibration solution, 1 pint

OAKTON “Singles” calibration solution pouches

WD-35653-00 Deionized rinse water solution pouches, 20/box.

WD-35653-10 447 μ S calibration solution pouches, 20/box.

WD-35653-11 1413 μ S calibration solution pouches, 20/box.

WD-35653-12 2764 μ S calibration solution pouches, 20/box.

WD-35653-13 15,000 μ S calibration solution pouches, 20/box.

Consult your OAKTON® Distributor for a complete selection of conductivity/TDS cells, solutions, holders, and accessories. Ask for bulletin Accessories A5.

To order OAKTON accessories, contact your OAKTON distributor.

16. Addendum 1: Conductivity to TDS Conversion Factors

- Factor**—the conductivity to ppm TDS conversion factor. Multiply conductivity by this factor to get ppm TDS for the type of TDS reading needed. Enter this factor into your OAKTON TDS/conductivity meter in Setup, Program 3, P3.0 on page 30. The meter automatically gives the most accurate TDS readings.
- 442**—a formulation that most closely represents the conductivity to ppm relationship, on average, for naturally occurring fresh water.
- TDS Your Material**—These columns are for you to write in your application specific conductivity to ppm values and conversion factors for future reference. See page 53.

Factor = actual TDS ÷ Actual Conductivity @ 25°C

| Conductivity at 25°C | TDS KCl ppm Value | TDS KCl Factor ¹ | TDS NaCl ppm Value | TDS NaCl Factor ¹ | TDS 442 ² ppm Value | TDS 442 ² Factor ¹ | TDS Your Material ³ ppm Value | TDS Your Material ³ Factor |
|----------------------|----------------------|--------------------------------|-----------------------|---------------------------------|-----------------------------------|---|---|--|
| 23 µS | 11.60 | 0.5044 | 10.69 | 0.4652 | 14.74 | 0.6409 | | |
| 84 µS | 40.38 | 0.5048 | 38.04 | 0.4755 | 50.50 | 0.6563 | | |
| 447 µS | 225.6 | 0.5047 | 215.5 | 0.4822 | 300.0 | 0.6712 | | |
| 1413 µS | 744.7 | 0.5270 | 702.1 | 0.4969 | 1000 | 0.7078 | | |
| 1500 µS | 757.1 | 0.5047 | 737.1 | 0.4914 | 1050 | 0.7000 | | |
| 2070 µS | 1045 | 0.5047 | 1041 | 0.5030 | 1500 | 0.7246 | | |
| 2764 µS | 1382 | 0.5000 | 1415 | 0.5119 | 2063 | 0.7463 | | |
| 8974 µS | 5101 | 0.5685 | 4487 | 0.5000 | 7608 | 0.8478 | | |
| 12880 µS | 7447 | 0.5782 | 7230 | 0.5613 | 11,367 | 0.8825 | | |
| 15000 µS | 8759 | 0.5839 | 8532 | 0.5688 | 13,455 | 0.8970 | | |
| 80 mS | 52,168 | 0.6521 | 48,384 | 0.6048 | 79,688 | 0.9961 | | |

17. Addendum 2: Calculating TDS Conversion Factors

The meter can be calibrated using TDS calibration standard solutions. The calibration standard only needs to give the TDS value at a standard temperature such as 25°C. To determine the conductivity-to-TDS conversion factor use the following formula:

$$\text{Factor} = \text{Actual TDS} \div \text{Actual Conductivity @ 25}^\circ\text{C}$$

Definitions:

Actual TDS: Value from the solution bottle label or as a standard you make using high purity water and precisely weighed salts.

Actual Conductivity: Value measured using a properly calibrated OAKTON Conductivity/TDS/Temperature meter.

Both the Actual TDS and the Actual Conductivity values must be in the same magnitude of units. For example, if the TDS value is in ppm the conductivity value must be in µS; if the TDS value is in ppt the conductivity value must be in mS.

Check this number by multiplying the conductivity reading by the factor in the above formula and the result is the TDS in ppm.

18. Addendum 3: Calculating Temperature Coefficients

To determine the temperature coefficient of your **sample solution** use this formula:

$$TC = 100 \times \frac{C_{T_2} - C_{T_1}}{C_{T_1}(T_2 - 25) - C_{T_2}(T_1 - 25)}$$

TC = Temperature coefficient

C_{T_1} = Conductivity at Temp. 1 C_{T_2} = Conductivity at Temp. 2

T_1 = Temp. 1 T_2 = Temp. 2, 25 = 25°C

NOTE: A controlled temperature water bath is ideal for this procedure.

1. Immerse the probe into a sample of solution and adjust the temperature coefficient to 0% (that is, no compensation) by entering setup Program 1, P1.1 see page 26 and pressing the **MR/▼** button until the upper display shows 0.0 and press **ENTER**. Press **CAL/MEAS** to come back to conductivity measurements.
2. Wait for 5 minutes. Note T_1 and C_{T_1} (conductivity at T_1).
3. Condition the sample and probe to a temperature (T_2 °C) that is about 5°C to 10°C different from T_1 , and note the conductivity reading C_{T_2} .

NOTE: Record your results for future reference in the back of this manual. Ideally T_1 and T_2 should bracket your measurement temperature, and should not differ by more than 5°C.

4. Enter the Temperature Coefficient in the meter. While in Program 1, P1.1 on page 26, use **MI/▲** or **MR/▼**.
5. Scroll to a required value from 0.0 to 10.0%/°C as determined in the procedure outlined above or in Section 4, Calibration on page 11-12.
6. Once this value is displayed, press **ENTER** to confirm the value. This coefficient will now be applied to all the meter readings.

19. Addendum 4: Calibration Tips

You only need **one** calibration for measurement throughout the entire range of the meter. If a range was not calibrated, the meter automatically detects the closest range calibrated and uses that calibration information. However, only the ranges that were calibrated have maximum accuracy.

If you are measuring in ranges greater than 20 mS or conductivity lower than 100 µS, **calibrate** the meter at least once a week to get specified ±1% F.S. accuracy. If you are measuring in the mid ranges and you washed the probe in deionized water and stored it dry, **calibrate** the meter at least once a month. Wet the probe for 10 minutes before calibrating or taking readings to saturate the probe surface and minimize drift. If you make measurements at extreme temperatures, calibrate the meter at least once a week.

Use only the conductivity/TDS probe specified for these meters. If you do not, you must measure the solution temperature separately and manually enter the solution temperature.