

## HT-10E-CIM HT-10E-CIA-FS

### INTRODUCTION

Little Giant Submersible High Temperature 10E Series Effluent Pumps are recommended for use in basins or lift stations and suitable for pumping effluent wastewater and other non-explosive, non-corrosive liquids. The 10E Series Effluent Pumps have 3/4" spherical solids handling capability.

Continuous automatic operation can be achieved with the use of the Integral Mercury Float Switch.

### UNPACKING

Little Giant pumps are carefully packaged, inspected and tested to insure safe operation and delivery. When you receive your pump, examine it carefully to determine that there are no broken or damaged parts that may occurred during shipment. If damage has occurred, make notation and notify the firm from which you purchased the pump and they will assist you in replacement or repair, if required.

### SPECIFICATIONS

<b>Discharge:</b>	10E Series — 1-1/2" NPT Vertical
<b>Intake:</b>	10E Series — 3/4" screened opening
<b>Housing:</b>	Motor — Cast Iron Relay — Cast Iron
<b>Volute:</b>	Cast Iron
<b>Screen:</b>	10E Series — Nylon
<b>Impeller:</b>	Vortex design corrosion-proof nylon, with pressure relief vanes
<b>Motor:</b>	Split phase induction, 1750 RPM, with automatic reset thermal overload protection
<b>Hardware:</b>	300 series stainless steel
<b>Dual Bearings:</b>	Double shielded ball
<b>Gaskets &amp; Seals:</b>	Neoprene, Nitrile for high temperature
<b>Shaft Seal:</b>	Mechanical, spring loaded, stationary carbon with Viton boot and rotating Ni Resist seat
<b>Power Cord:</b>	16 AWG 3-conductor copper stranded type SJOW-A/SJOW
<b>Cooling:</b>	The motor housing contains a cooling oil to provide cooling for the motor and to lubricate bearings and seals. These pumps are capable of operating with the motor housing partially exposed for extended periods of time, providing sufficient motor cooling and bearing lubrication; however, for the best cooling and longest motor life, the liquid level being pumped should normally be above the top of the cast iron motor housing.

### SAFETY GUIDELINES



**WARNING:** RISK OF ELECTRIC SHOCK. THIS PUMP IS SUPPLIED WITH A GROUNDING CONDUCTOR AND/OR GROUNDING-TYPE ATTACHMENT PLUG. TO REDUCE THE RISK OF ELECTRICAL SHOCK, BE CERTAIN THAT IT IS CONNECTED TO A PROPERLY GROUNDED, GROUNDING-TYPE RECEPTACLE.

Your 115V pump is equipped with a 3-prong electrical plug. The third prong is to ground the pump to prevent possible electrical shock hazard. Do not remove the third prong from the plug. A separate branch circuit is recommended. Do not use an extension cord.

When a pump is in a basin, etc. do not touch motor, pipes or water until unit is unplugged or shut off. If your installation has water or moisture present, do not touch wet area until all power has been turned off. If shut-off box is not accessible, call the electric company to shut off service to the house, or call your local fire department for instructions. Failure to follow this warning can result in fatal electrical shock.

The flexible jacketed cord assembly mounted to the pump must not be modified in any way, with the exception of shortening the cord to fit into a control panel. Any splice between the pump and the control panel must be made within a junction box and mounted outside of the basin, and comply with the National Electrical Code. Do not use the power cord for lifting the pump.

The pump motor is equipped with an automatic resetting thermal protector and may restart unexpectedly. Protector tripping is an indication of motor overloading as a result of operating the pump at low heads (low discharge restriction), excessively high or low voltage, inadequate wiring, incorrect motor connections, or a defective motor or pump.

1. Read all instructions and Safety Guidelines thoroughly. Failure to follow the guidelines and instructions could result in serious bodily injury and/or property damage.
2. DO NOT USE TO PUMP FLAMMABLE OR EXPLOSIVE FLUIDS SUCH AS GASOLINE, FUEL OIL, KEROSENE, ETC. DO NOT USE IN EXPLOSIVE ATMOSPHERES OR HAZARDOUS LOCATIONS AS CLASSIFIED BY NEC, ANSI/NFPA70. FAILURE TO FOLLOW THIS WARNING CAN RESULT IN PERSONAL INJURY AND/OR PROPERTY DAMAGE.
3. During normal operation the pump is immersed in water. Also, during rain storms, water may be present in the surrounding area of the pump. Caution must be used to prevent bodily injury when working near the pump:
  - a. The plug must be removed from the receptacle prior to touching, servicing or repairing the pump.
  - b. To minimize possible fatal electrical shock hazard, extreme care should be used when changing fuses. Do not stand in water while changing fuses or insert your finger into the fuse socket.
4. Do not run the pump in a dry basin. If the pump is run in a dry basin, the surface temperature of the pump will rise to a high level. This high level could cause skin burns if the pump is touched and will cause serious damage to your pump.
5. Do not oil the motor. The pump housing is sealed. A high-grade, high-temperature dielectric oil devoid of water has been put into the motor housing at the factory. Use of other oil could cause serious electric shock and/or permanent damage to the pump.
6. This pump's motor housing is filled with a dielectric lubricant at the factory for optimum motor heat transfer and lifetime lubrication of the bearings. Use of any other lubricant could cause damage and void the warranty. This lubricant is non-toxic; however, if it escapes the motor housing, it should be removed from the surface quickly by placing newspapers or other absorbent material on the water surface to soak it up, so aquatic life is undisturbed.
7. Allow pump to cool (4 hours minimum) prior to servicing. The oil is pressurized at elevated temperatures.

## INSTALLATION

Pump must be installed in a suitable basin which is at least 18" in diameter and 24" deep, and installed in accordance with local electrical and plumbing codes.

The HT-10E Series Effluent Pumps feature a 1-1/2" female NPT discharge.

Pump can be installed with materials capable of with standing 200°F water. Proper adapters are required to connect piping to pump.

Pump must be placed with its base on a hard level surface. Never place pump directly on clay, earth or gravel surfaces.

A check valve must be used in the discharge line to prevent back flow of liquid into the basin. The check valve should be a free flow valve that will easily pass solids.

**CAUTION:** For best performance of check valves, when handling solids install in a horizontal position or at an angle of no more than 45°. Do not install check valve in a vertical position as solids may settle in valve and prevent opening on start-up.

When a check valve is used drill a 3/16" hole in the discharge pipe approximately 1" to 2" above the pump discharge connection and below check valve to prevent air locking of the pump.

## WIRING

Check local electrical and building codes before installation. The installation must be in accordance with their regulations as well as the most recent National Electrical Code (NEC).

To conform to the National Electrical Code all pumps must be wired with 14 AWG or larger wire. For runs to 250', 14 AWG wire is sufficient. For longer runs, consult a qualified electrician or the factory.

Pump should be connected or wired to its own circuit with no other outlets or equipment in the circuit line. Fuses and circuit breaker should be of ample capacity in the electrical circuit. See chart below.

H.P.	VOLTAGE	FUSE OR CIRCUIT BREAKER AMPS
1/2	115	20

## MERCURY FLOAT SWITCH LEVEL CONTROL

The FS series pumps are equipped with an integral float switch level control for automatic operation. This level control uses a mercury switch sealed in a specially designed high temperature float cylinder. **PLEASE NOTE THAT ANY PRODUCT CONTAINING MERCURY MUST BE RECYCLED OR DISPOSED ACCORDING TO LOCAL, STATE AND FEDERAL CODES.**

Figure 1. Typical Installation

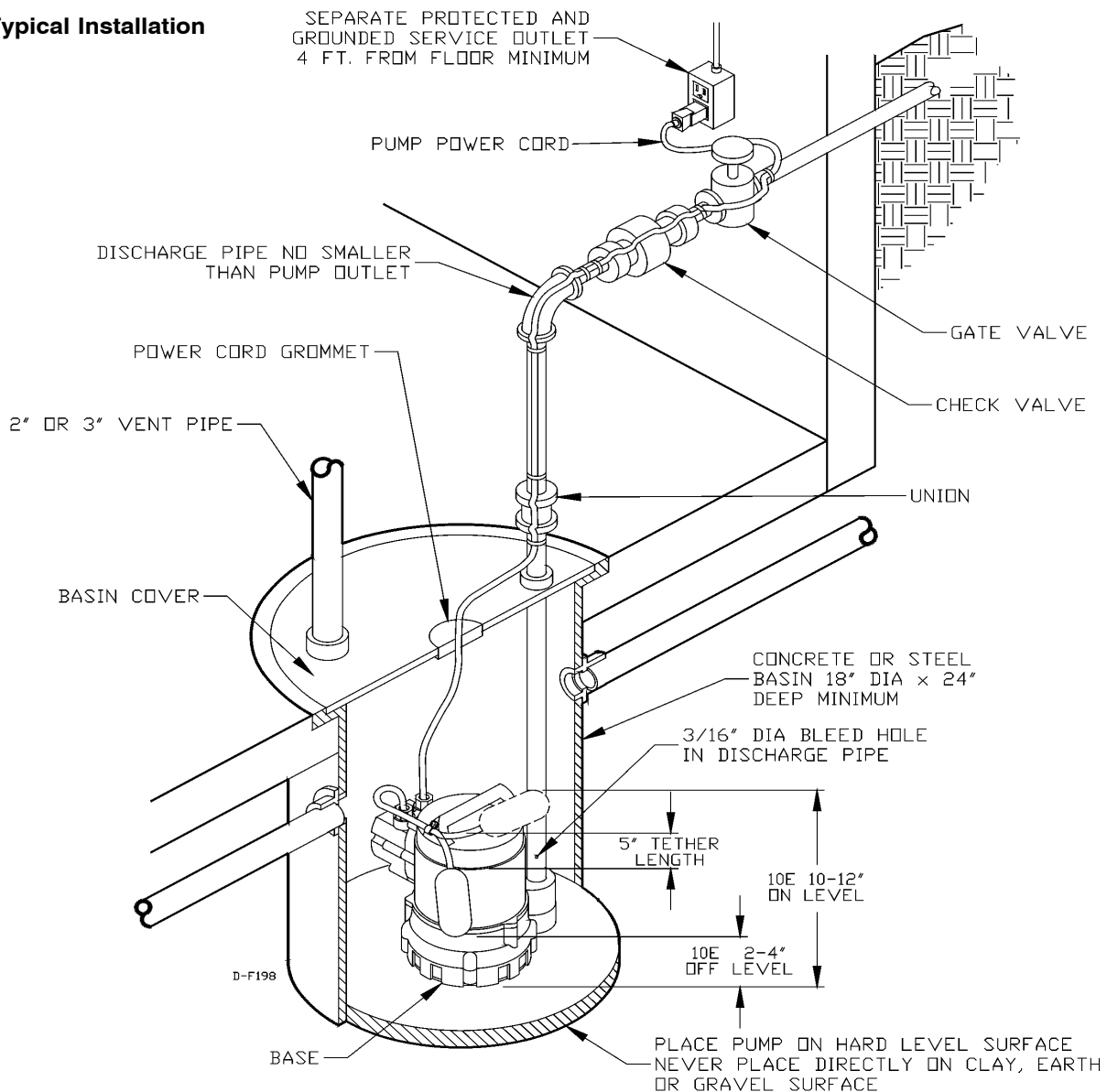
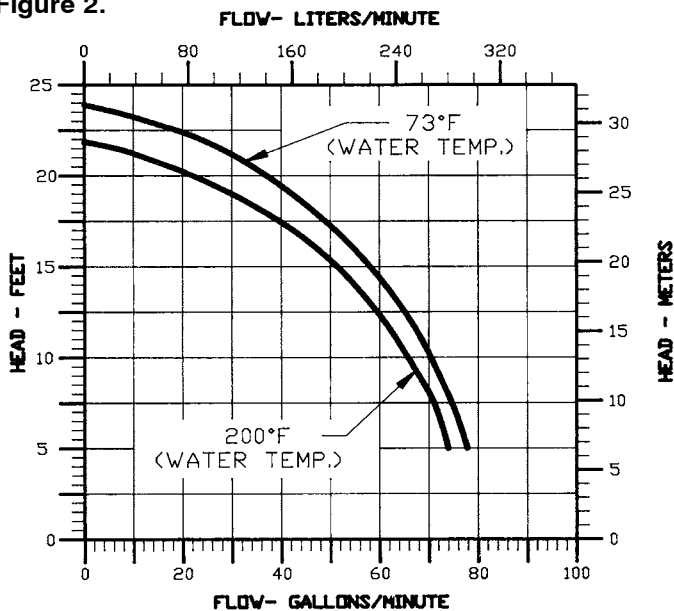

Figure 2.



When the level rises in the basin, the cylinder floats up with the level. When the cylinder position is at an angle of about 45°, the mercury flows over and makes contact with electrodes in the switch. This starts the pump motor.

As the level draws down, the cylinder floats down and when it is again at an angle of about 45°, the mercury flows away from the electrodes and the pump motor stops.

**NOTE:** BE CERTAIN PUMP IS SECURE IN BASIN AND CYLINDER FLOATS UNOBSTRUCTED WITHOUT TOUCHING THE BASIN WALLS OR PLUMBING.

### REMOTE FLOAT SWITCH INSTALLATION

1. The float switch consists of three parts:
  - a. mercury switch
  - b. cord clamp
  - c. clamp screw

**NOTE:** If screw is lost, use a #10-24 x 1/2" long tapping screw.
2. Attach cord clamp to pump cover as shown in Figure 1. The clamp must be positioned as shown to allow free operation of float. Be sure to locate pump and switch power cords away from switch float.
3. A 5" tether length is recommended. When a tether length of 5" is used, a minimum basin diameter of 18" is recommended. The tether length is measured as shown in illustration at right.
4. After desired tether length is established hand tighten clamp screw.
5. **TESTING:** Plug switch into outlet without water in basin. Lift float and watch for pump to operate. Do not run pump for more than 5 seconds.

## TESTING PUMP OPERATION FS SERIES AUTOMATIC PUMPS

1. These pumps are equipped with a float operated mercury switch.
2. When these pumps are installed in a basin with a sealed cover, switch operation cannot be observed. The sump cover usually will have a spare hole that is plugged with a rubber plug. This plug can be removed and switch operation can be observed.
3. Run water into pump until pump starts.
4. Be sure gate valve in discharge line is open.
5. Allow pump to operate through several on-off cycles.

### MANUAL PUMPS

The pump cord for these pumps can be plugged directly into a properly grounded receptacle with voltage consistent with pump nameplate for continuous pump operation.

**CAUTION:** This type of operation should be used only for emergency use or when a large volume of water is to be pumped. Pump must not be allowed to run dry. If pump is run dry, it may damage pump and void the warranty.

### MAINTENANCE AND SERVICE

If pump does not operate properly, consult the Troubleshooting Chart. If trouble cannot be located with the steps shown, consult your pump dealer or take pump to a Little Giant authorized service center.

**NOTE:** Relay Cover Mounting Screws (item #23) requires 15-20 in-lbs. torque.

**CAUTION:** When working on pump or switch, always unplug pump power cord in addition to removing fuse or shutting off circuit breaker before working on pump.

### CLEANING IMPELLER AND VOLUTE

**WARNING:** DO NOT REMOVE THE 3 SOCKET HEAD CAP SCREWS (ITEM #1 ON PARTS LIST). THE MOTOR SECTION OF YOUR PUMP IS PERMANENTLY LUBRICATED WITH DIELECTRIC OIL AND SEALED AT THE FACTORY. REMOVAL OF THESE SOCKET HEAD CAP SCREWS BY ANYONE OTHER THAN AN AUTHORIZED LITTLE GIANT SERVICE CENTER WILL BREAK THIS SEAL AND VOID THE WARRANTY.

1. On 10E Series Effluent pumps: Remove 5 screws (item 13 on parts list) that hold screen base and base plate to volute/plate.
2. Clean impeller and volute passage. Do not use strong solvents on impeller.
3. Be sure impeller turns freely after cleaning.
4. **WARNING:** DO NOT REMOVE IMPELLER. WARRANTY IS VOID IF MOTOR HOUSING, IMPELLER OR SEALS HAVE BEEN REMOVED. ANY REPAIR ON MOTOR MUST BE DONE BY AN AUTHORIZED LITTLE GIANT SERVICE CENTER.

**Figure 3.**

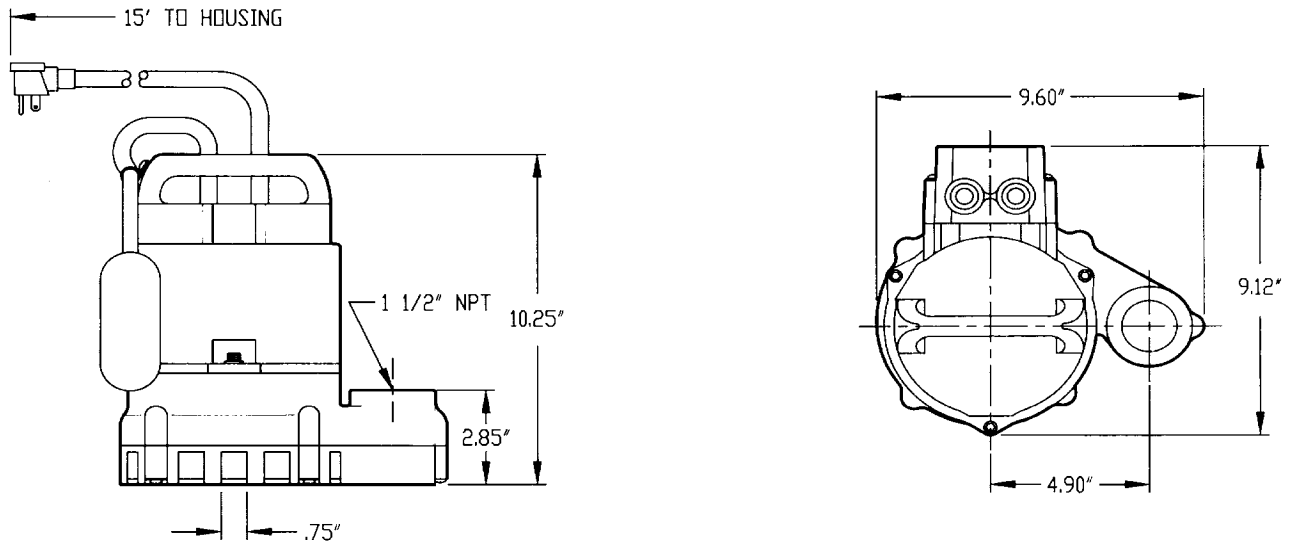

MODEL NO.	CATALOG NO.	HP	VOLTS	SOLIDS SIZE (dia. in.)	AMPS/WATTS	PERFORMANCE (GPM @ HEAD)							PWR CRD (ft.)	WEIGHT (lbs.)	DIMENSIONS (HxLxW) (in.)
						WATER TEMP.	5'	10'	15'	20'	(Ft.)	P.S.I.			
HT-10E-CIM	511600	1/2	115	3/4	10/900	73°F	80	70	59	37	24	10.4	15	38	10.25x9.6x9.12
						200°F	75	67	52	22	22	9.5			
HT-10E-CIA-FS	511700	1/2	115	3/4	10/900	73°F	80	70	59	37	24	10.4	15	39	10.25x9.6x9.12
						200°F	75	67	52	22	22	9.5			

All Models are 60 Hz.

**TROUBLESHOOTING INFORMATION • INFORMATION SUR LA RELÈVE DES DÉRANGEMENTS  
• INFORMACION DE INVESTIGACION DE AVERIAS**

<b>PROBLEM • FONCTIONNEMENT DÉFECTUEUX • PROBLEMA</b>	<b>PROBABLE CAUSES • CAUSES PROBABLES • CAUSAS PROBABLES</b>	<b>CORRECTIVE ACTIONS • SOLUTIONS • SOLUCION</b>
Pump does not turn on.	Pump not plugged in.	Plug in pump.
	Circuit breaker shutoff of fuse removed.	Turn on circuit breaker or replace fuse. (Freezing water may cause circuit breaker to trip, or fuse to blow.)
	Accumulation of trash on mercury float switch.	Clean float.
	Mercury float switch obstruction.	Check float path and provide clearance.
	Defective switch.	Have pump serviced.
	Defective motor.	Have pump serviced.
	Thermal protector activated.	Allow to cool down to room temperature.
Pump will not shut off.	Mercury switch float obstruction.	Check float path and provide clearance.
	Pump is air locked.	Shut power off for approximately 1 minute, then restart. Repeat several times to clear air from pump. If system includes a check valve, a 3/16" hole should be drilled in discharge pipe approximately 2" above discharge connections.
	Liquid inflow matches pump capacity.	Larger pump required.
	Defective switch	Have pump serviced.
	Loose connection in level control wiring.	Check control wiring.
Pump runs but does not discharge liquid.	Check valve installed backwards.	Check flow indicating arrow on check valve body to ensure it is installed properly.
	Check valve stuck or plugged.	Remove check valve and inspect for proper operation.
	Lift too high for pump.	Check rating table.
	Inlet to impeller plugged.	Pull pump and clean.
	Pump is air locked.	(See corrective action above.)
Pump does not deliver rated capacity.	Lift too high for pump.	Check rated pump performance.
	Low voltage, speed too slow.	Check for proper supply voltage to make certain it corresponds to nameplate voltage.
	Impeller or discharge pipe is clogged.	Pull pump and clean. Check pipe for scale or corrosion.
	Impeller wear due to abrasives.	Replace worn impeller.
Pump cycles continually.	No check valve in long discharge pipe allowing liquid to drain back into basin.	Install a check valve in discharge line.
	Check valve leaking.	Inspect check valve for correct operation.
	Basin too small for inflow.	Install larger basin.

Figure 4.

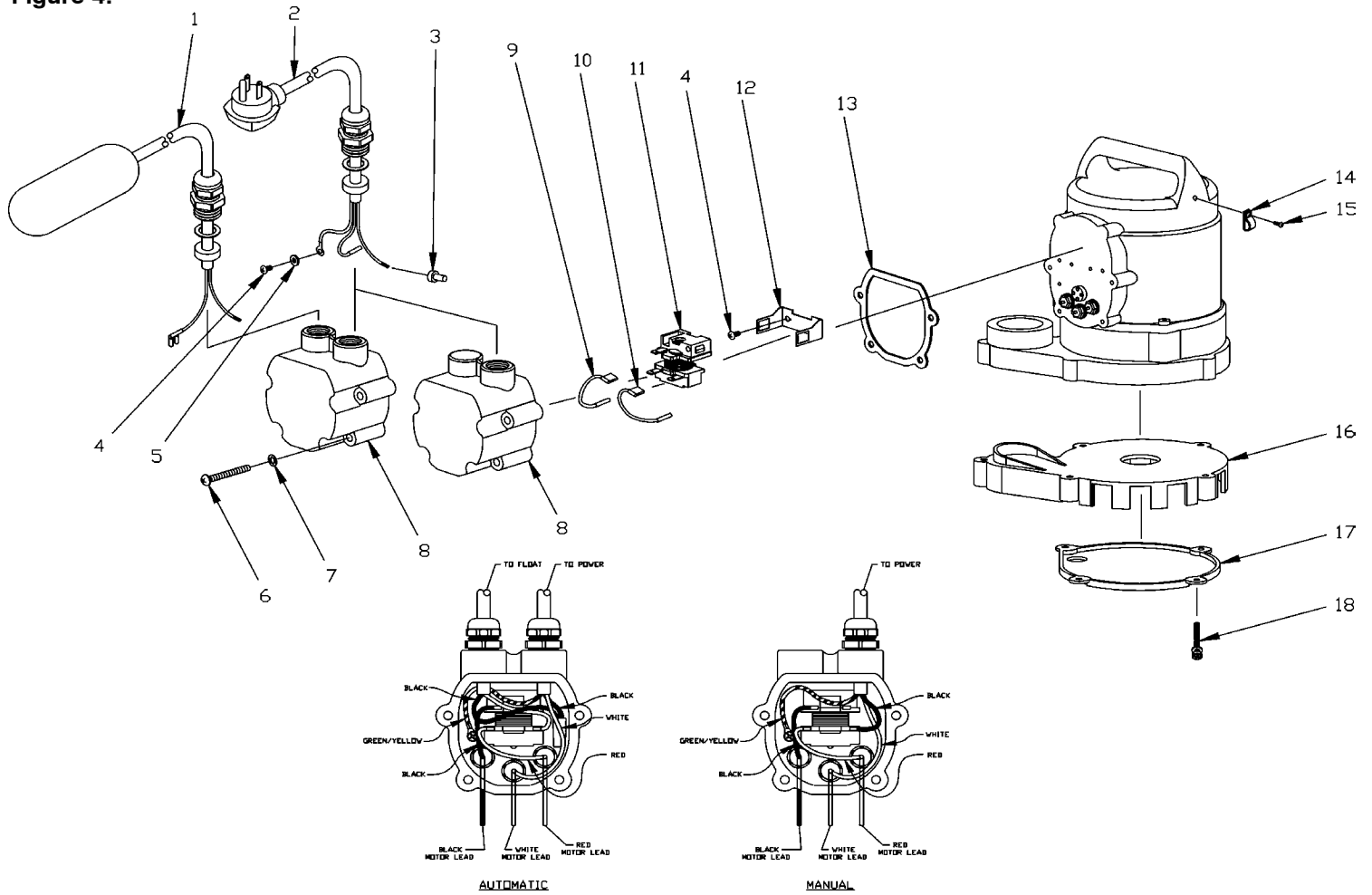

### REPLACEMENT PARTS

ITEM NO.	PART NO.	DESCRIPTION	QTY.	Catalog No./ Model No.	
				511600 HT-10E-CIM	511700 HT-10E-CIA-FS
1	950223	Float Switch Assy.	1		•
2	951600	Wiring Harness Assy., Automatic	1		•
2	951538	Wiring Harness Assy., Manual	1	•	
3	950400	Connector, Closed End	1		•
4	902307	Screw, Tap, #6-32 x 1/4"	3	•	•
5	921028	Washer, Lock, #6 Int.	1	•	•
6	901530	Screw, Mach, 10-24 x 1-5/8"	4	•	•
7	921023	Washer, Lock, #10 SS Int.	4	•	•
8	110077	Housing, Relay, Automatic	1		•
8	110067	Housing, Relay, Manual	1	•	
9	951962	Lead Wire Assy., Black	1	•	•
10	951965	Lead Wire Assy., Red	1	•	•
11	950927	Relay, 115V	1	•	•
12	950928	Bracket, Relay Mounting	1	•	•
13	111661	Gasket, Relay Housing	1	•	•
14	927027	Loop Clamp	1		•
15	902516	Screw, Tap, 10-24 x 1/2"	1		•
16	109160	Base, Screen	1	•	•
17	109161	Plate, Screen Base	1	•	•
18	909024	Screw/Washer, #10-24 x 1.46	5	•	•

**LIMITED WARRANTY  
SUMP, EFFLUENT & RESIDENTIAL SEWAGE**

Little Giant #HT-10E Series Submersible Effluent Pumps are recommended for use in sumps, basins or lift stations and suitable for pumping basement drainage water, effluent, wastewater and other non-explosive, non-corrosive, non-abrasive liquids not above 200°F with up to ¾" spherical solids handling ability. (NOT TO BE USED FOR SEWAGE WATER EXCEPT TO PUMP SEPTIC TANK EFFLUENT)

The above noted Little Giant product is guaranteed to be in perfect condition when it leaves our factory. During the time periods and subject to the conditions hereinafter set forth, LITTLE GIANT PUMP COMPANY, subsidiary of Franklin Electric Company, Inc., will repair or replace to the original user or consumer any portion of your new LITTLE GIANT product which proves defective due to materials or workmanship of LITTLE GIANT. Contact your nearest Authorized Little Giant Service Dealer for warranty service. At all times LITTLE GIANT shall have and possess the sole right and option to determine whether to repair or replace defective equipment, parts, or components. Damage due to lightning or conditions beyond the control of LITTLE GIANT is NOT COVERED BY THIS WARRANTY.

**WARRANTY PERIOD**

**PUMPS:** 12 months from date of installation or 18 months from date of manufacture, whichever occurs first.

**LABOR, ETC. COSTS:** LITTLE GIANT shall IN NO EVENT be responsible or liable for the cost of field labor or other charges incurred by any customer in removing and/or affixing any LITTLE GIANT product, part or component thereof.

**THIS WARRANTY WILL NOT APPLY:**

1. to defects or malfunctions resulting from failure to properly install, operate, or maintain the unit in accordance with printed instructions provided.
2. to failures resulting from abuse, accident or negligence.
3. to normal maintenance services and the parts used in connection with such service
4. to units which are not installed in accordance with applicable local codes, ordinances and good trade practices.
5. unit is used for purposes other than for what it was designed and manufactured.
6. if pump exposed to but not limited to the following: sand, gravel, cement, grease, plaster, mud, tar, hydrocarbons, or hydrocarbon derivatives (oil, gasoline, solvents, etc.) or other abrasive or corrosive substances.

7. if pump has been used for continuous pumping of suitable liquids above 200°F.
8. if power cord has been cut or spliced.
9. if pump has been dismantled by customer. (Dealer only can dismantle pump for field service.)

**RETURNED OR REPLACED PRODUCT:** Any item to be replaced under the Warranty must be returned to LITTLE GIANT at Oklahoma City, OK or such other place as LITTLE GIANT may designate, freight prepaid.

**PRODUCT IMPROVEMENTS:** Little Giant reserves the right to change or improve its products or any portions thereof without being obligated to provide such a change or improvement for units sold and/or shipped to such change or improvement.

**DISCLAIMER:** Any oral statements about the product made by the seller, the manufacturer, the representatives or any other parties, do not constitute warranties, shall not be relied upon by the user, and are not part of the contract for sale. Seller's and manufacturer's only obligation, and buyer's only remedy, shall be the replacement and/or repair by the manufacturer of the product as described above. Neither seller nor the manufacturer shall be liable for any injury, loss or damage, direct, incidental or consequential (including, but not limited to, incidental or consequential damages for lost profits, lost sales, injury to person or property, or any other incidental or consequential loss), arising out of the use or the inability to use the product, and the user agrees that no other remedy shall be available to it. Before using, the user shall determine the suitability of the product for his intended use, and user assumes all risk of liability whatsoever in connection therewith. The warranty and remedy described in this limited warranty is an EXCLUSIVE warranty and remedy and is IN LIEU OF any other warranty or remedy, expressed or implied, which other warranties and remedies are hereby expressly EXCLUDED, including but not limited to any implied warranty of MERCHANTABILITY OR FITNESS FOR A PARTICULAR PURPOSE. Some states do not allow the exclusive or limitation of incidental or consequential damages, so the above limitation or exclusion may not apply to you. This warranty gives you specific legal rights, and you may also have other rights which vary from state to state.

In the absence of other suitable proof of the installation date, the effective date of this warranty will be based upon the date of manufacture plus one year. Direct All Notices, etc. To: Service Department, LITTLE GIANT PUMP COMPANY, 3810 N. Tulsa, Oklahoma City, OK 73112.

**DETERMINATION OF UNIT DATE OF MANUFACTURE:** (9-87) month and year stamped on pump and/or serial number on pump nameplate coded to indicate year of manufacture.

---

**For Parts or Repair, please contact.....1.888.572.9933**  
**For Technical Assistance, please contact.....1.888.956.0000**

**[www.LittleGiant.com](http://www.LittleGiant.com)**  
**[customerservice@lgpc.com](mailto:customerservice@lgpc.com)**

---