

Configuration Data

Model **P14** **1** - **358SI**

Series P

Electronic Metering Pumps

Manual Control

Speed (stroking frequency) fixed and stroke length manually adjustable.

P02 --- 0.20 GPH (0.79 l/h) --- 150 psi (10.3 Bar)
 P03 --- 0.42 GPH (1.6 l/h) --- 110 psi (7.6 Bar)
 P04 --- 0.58 GPH (2.2 l/h) --- 250 psi (17.3 Bar)
 P05 --- 1.00 GPH (3.8 l/h) --- 110 psi (7.6 Bar)
 P06 --- 2.00 GPH (7.6 l/h) --- 50 psi (3.5 Bar)
 P08 --- 3.20 GPH (12.1 l/h) --- 22 psi (1.5 Bar)

Dual Manual Control

Speed (stroking frequency) and stroke length manually adjustable.

P12 --- 0.20 GPH (0.79 l/h) --- 150 psi (10.3 Bar)
 P13 --- 0.42 GPH (1.6 l/h) --- 110 psi (7.6 Bar)
 P14 --- 0.58 GPH (2.2 l/h) --- 250 psi (17.3 Bar)
 P15 --- 1.00 GPH (3.8 l/h) --- 110 psi (7.6 Bar)
 P16 --- 2.00 GPH (7.6 l/h) --- 50 psi (3.5 Bar)
 P18 --- 3.20 GPH (12.1 l/h) --- 22 psi (1.5 Bar)

Instrument Responsive / Manual

Manual adjustment features of Series P1 plus switch conversion to external control for automatic systems.

P74 --- 0.58 GPH (2.2 l/h) --- 250 psi (17.3 Bar)
 P75 --- 1.00 GPH (3.8 l/h) --- 110 psi (7.6 Bar)
 P76 --- 2.00 GPH (7.6 l/h) --- 50 psi (3.5 Bar)
 P78 --- 3.20 GPH (12.1 l/h) --- 22 psi (1.5 Bar)

Voltage Code

1 ----- 120 VAC US Plug
 2 ----- 240 VAC US Plug
 3 ----- 220-240 VAC DIN Plug
 5 ----- 240-250 VAC, UK Plug
 6 ----- 240-250 VAC, Aust./NZ Plug
 7 ----- 220 VAC, Swiss Plug

Liquid End

See next page for complete liquid end specifications and selection.

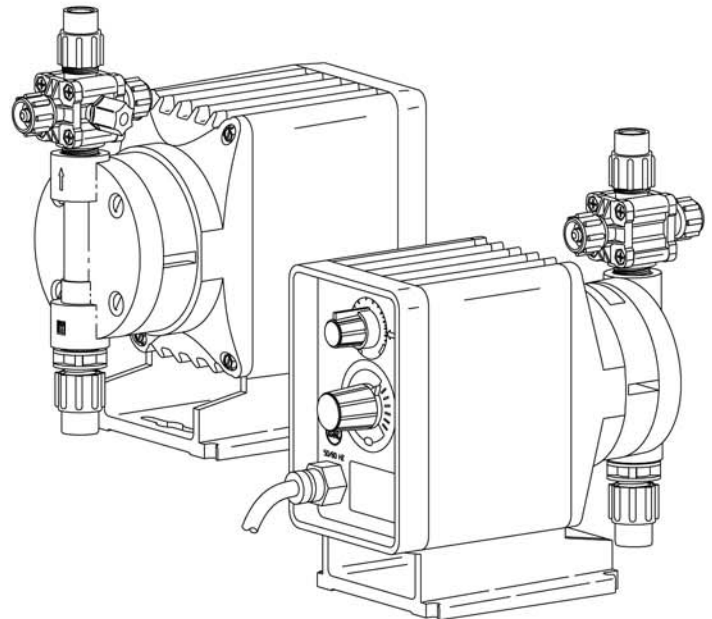

Dimensions

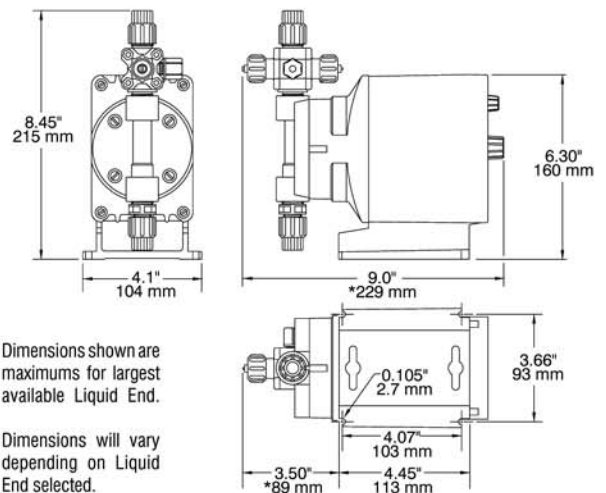

Specifications

Series	Strokes Per Minute (Adjustable)		Stroke Length (Adjustable) Recommended Minimum	Average Input Power @ Max Speed	Shipping Weight
	Min	Max			
P02, P03	fixed - 60		30%	22 watts	7.6 lbs (3.5 kg)
P04, P05	fixed - 100		20%		
P06, P08	.6	60	30%		
P12, P13	fixed - 60		30%		
P14, P74	1		100	20%	
P15, P75	1		100	20%	
P16, P76	1		100	20%	
P18, P78	1		100	20%	



8 Post Office Square
 Acton, MA 01720 USA
 TOLL FREE: (800) 564-1097
 TEL: (978) 263-9800
 FAX: (978) 264-9172
<http://www.lmipumps.com>



Configuration Data & Materials of Construction

Drive Assembly	Liquid End No.	Size Code	Materials of Construction				Accessory	Tubing & Connections	
			Head & Fittings	Balls	Liquifram™	Check Valve		Discharge	Suction
P02 - P04 - P12 - P14 - P74 -	458SI†	0.5	PVC / PVC	Ceramic	Fluorofilm™	PVDF / Polyprel®	4FV	PE .250" O.D.	
	450SI†	0.5	Acrylic / PVC	Ceramic	Fluorofilm™	PVDF / Polyprel®	4FV	PE .250" O.D.	
	450FI†	0.5	Acrylic / PVC	PTFE	Fluorofilm™	PVDF / Polyprel®	4FV	PE .250" O.D.	
	358SI†	0.5	PVC / PVC	Ceramic	Fluorofilm™	PVDF / Polyprel®	4FV	PE .250" O.D.	
	353SI†	0.5	PVDF / PVDF	Ceramic	Fluorofilm™	PVDF / PTFE	4FV	PE .250" O.D.	
P74 -	352SI†	0.5	PVDF / PVDF	Ceramic	Fluorofilm™	PVDF / Polyprel®	4FV	PE .250" O.D.	
	156HV	0.5	Acrylic / PP	316S.S.	Fluorofilm™	Hypalon®		PE .5" O.D. Vinyl .938" O.D.	
	155HV	0.5	Polypropylene	316S.S.	Fluorofilm™	PTFE		PE .5" O.D. Vinyl .938" O.D.	
	257	0.5	316 S.S.	316S.S.	Fluorofilm™	316S.S.		Pipe 1/4" NPT M	
P03 -	498SI†	0.9	PVC / PVC	Ceramic	Fluorofilm™	PVDF / Polyprel®	4FV	PE .375" O.D.	
P05 -	490SI†	0.9	Acrylic / PVC	Ceramic	Fluorofilm™	PVDF / Polyprel®	4FV	PE .375" O.D.	
P13 -	490FI†	0.9	Acrylic / PVC	PTFE	Fluorofilm™	PVDF / Polyprel®	4FV	PE .375" O.D.	
P15 -	398SI†	0.9	PVC / PVC	Ceramic	Fluorofilm™	PVDF / Polyprel®	4FV	PE .375" O.D.	
P75 -	393SI†	0.9	PVDF / PVDF	Ceramic	Fluorofilm™	PVDF / PTFE	4FV	PE .375" O.D.	
	392SI†	0.9	PVDF / PVDF	Ceramic	Fluorofilm™	PVDF / Polyprel®	4FV	PE .375" O.D.	
	86HV	0.9	Acrylic / PP	316S.S.	Fluorofilm™	Hypalon®		PE .5" O.D. Vinyl .938" O.D.	
	85HV	0.9	Polypropylene	316S.S.	Fluorofilm™	PTFE		PE .5" O.D. Vinyl .938" O.D.	
	297	0.9	316S.S.	316S.S.	Fluorofilm™	316S.S.		Pipe 1/4" NPT M	
P06 -	468SI†	1.8	PVC / PVC	Ceramic	Fluorofilm™	PVDF / Polyprel®	4FV	PE .375" O.D.	
P08 -	460SI†	1.8	Acrylic / PVC	Ceramic	Fluorofilm™	PVDF / Polyprel®	4FV	PE .375" O.D.	
P16 -	460FI†	1.8	Acrylic / PVC	PTFE	Fluorofilm™	PVDF / Polyprel®	4FV	PE .375" O.D.	
P18 -	368SI†	1.8	PVC / PVC	Ceramic	Fluorofilm™	PVDF / Polyprel®	4FV	PE .375" O.D.	
P76 -	363SI†	1.8	PVDF / PVDF	Ceramic	Fluorofilm™	PVDF / PTFE	4FV	PE .375" O.D.	
P78 -	362SI†	1.8	PVDF / PVDF	Ceramic	Fluorofilm™	PVDF / Polyprel®	4FV	PE .375" O.D.	
	76HV	1.8	Acrylic / PP	316S.S.	Fluorofilm™	Hypalon®		PE .5" O.D. Vinyl .938" O.D.	
	75HV	1.8	Polypropylene	316S.S.	Fluorofilm™	PTFE		PE .5" O.D. Vinyl .938" O.D.	
	277	1.8	316S.S.	316S.S.	Fluorofilm™	316S.S.		Pipe 1/4" NPT M	

See front page for voltage code specifications.

3FV indicates that the pump is equipped with an LMI Three Function Valve (pressure relief, priming aid, line drain).

Fluorofilm™ is a copolymer of PTFE and PFA. Polyprel® is an elastomeric PTFE copolymer.

† To specify 1/4" NPT male, change 'I' to 'P'. To specify black, UV resistant tubing, change 'I' to 'U'. To specify Bleed 4FV, change 'S' to 'B'. To specify 3FV, change 'S' to 'T'.

4FV indicates that the pump is equipped with an LMI Four Function Valve. This diaphragm type, anti-syphon/pressure relief valve is installed on the pump head. It provides anti-syphon protection and aids in priming, even under pressure.

Polyprel is a registered trademark of Liquid Metronics Incorporated. Fluorofilm and Liquifram are trademarks of Liquid Metronics Incorporated. Hypalon is a registered trademark of E. I. du Pont de Nemours & Co., Inc.

Output Information

Series	Gallons per Hour		Liters per Hour		mL/cc per Minute		mL/cc per Stroke		Maximum Injection Pressure	
	Min	Max	Min	Max	Min	Max	Min	Max		
P02	0.063	0.21	0.237	0.79	3.94	13	0.07	0.22	150 psi	(10.3 Bar)
P03	0.125	0.42	0.473	1.6	7.89	26	0.13	0.44	110 psi	(7.6 Bar)
P04	0.117	0.58	0.442	2.2	7.36	37	0.07	0.37	250 psi	(17.3 Bar)
P05	0.200	1.0	0.757	3.8	12.62	63	0.13	0.63	110 psi	(7.6 Bar)
P06	0.400	2.0	1.510	7.6	25.23	126	0.25	1.26	50 psi	(3.5 Bar)
P08	0.640	3.2	2.422	12.1	40.37	202	0.40	2.02	22 psi	(1.5 Bar)
P12	0.001	0.21	0.002	0.79	0.04	13	0.07	0.22	150 psi	(10.3 Bar)
P13	0.001	0.42	0.005	1.6	0.08	27	0.13	0.44	110 psi	(7.6 Bar)
P14, P74	0.001	0.58	0.004	2.2	0.07	37	0.07	0.37	250 psi	(17.3 Bar)
P15, P75	0.002	1.0	0.008	3.8	0.13	63	0.13	0.63	110 psi	(7.6 Bar)
P16, P76	0.004	2.0	0.015	7.6	0.25	126	0.25	1.26	110 psi	(7.6 Bar)
P18, P78	0.006	3.2	0.024	12.1	0.40	202	0.40	2.02	22 psi	(1.5 Bar)