

# INSTALLATION OPERATING & MAINTENANCE MANUAL

PIRANHA 08/09  
SCAVENGER  
SE4 & SE5 PUMPS  
SE10 PUMPS  
SJ4 & SJ5 PUMPS  
SJ10 PUMPS

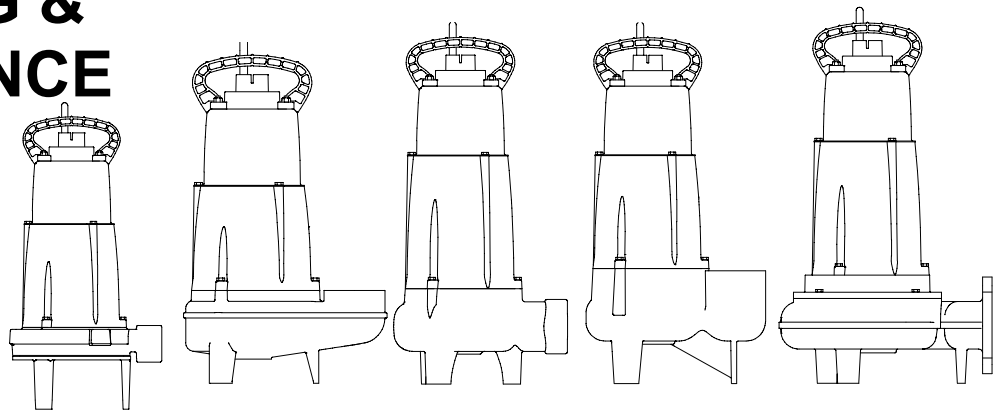

## CAUTION

Three-phase only. "**CAUTION:** Risk of Shock. Do not remove cord and strain relief. Do not connect conduit to pump", and "**INSTALLER:** This pump is not provided with a supply connection, therefore one of the following means must be provided by the installer: (1) A suitably rated, grounding-type attachment plug must be provided for connection to the branch circuit supply, or (2) A Listed junction box, Listed outlet box, or Listed wiring compartment and their associated fittings must be provided by the installer for supply connection. This provision must reduce the likelihood of water entry during temporary, limited submersion. See Instruction Manual for Further Details. Only qualified personnel shall install the pump.

## WARNING

Single ~ phase only. "**WARNING:**

**WARNING:** Risk of electrical shock-this pump is supplied with a grounding conductor and grounding-type attachment plug. To reduce the risk of electrical shock, be certain that it is connected only to a properly grounded, grounding receptacle, motor is thermally protected.

To reduce risk of electrical shock, pull plug before servicing this pump.

This pump has not been investigated for use in swimming pools.

## 1.0 INTRODUCTION

1.1 The PIRANHA/SCAVENGER series submersible pumps are designed to be used for pumping clean or contaminated water, residential or industrial sewage, or septic tank effluent. All liquids to be pumped must be compatible with the materials of construction of the pump.

1.2 The pump consists of a fully submersible motor, close coupled to a non-clog type pump end. The motor housing and volute are cast iron. The cap, as well as all external hardware are stainless steel.

## 2.0 UNPACKING AND INSPECTION

2.1 Carefully open the shipping container and remove the pump. Check packing material for spare parts before discarding.

2.2 Thoroughly inspect the pump for shipping damage. Pay special attention to the power cable, and discharge port threads. Report any damage to the shipping carrier. In the event of damage, retain all packing material; it may be required to support a damage claim.

2.3 If the pump is to be stored before use, store it in its shipping carton, in a dry, temperature stable environment. Do not store the pump in an incomplete wet well, or in an environment where the free end of the power cable can be exposed to moisture.

### 3.0 INSTALLATION

3.1 Pumps are shipped from ABS ready for installation and use. Confirm that your electrical supply is of the correct voltage, and that it can handle the current draw of the motor. A separate branch circuit for the pump is recommended. Refer to the pump name plate for voltage and current requirements.

3.2 Pumps may be installed in open or closed type basins made of a variety of different materials including fiberglass, concrete, plastic, or steel. The support under the basin must be stable and level.

3.3 Basins should be sized to minimize the number of starts per hour that the pump will experience. Generally, a basin of 18 inches in diameter, and 30 inches deep is considered the minimum size for most applications. Starts per hour should not exceed 10. If floats are to be used to operate the pump, the basin must be large enough so that the floats can swing through their entire range without contacting the pump or basin wall.

3.4 A vent pipe is required on closed type basins. Consult local codes for installation requirements.

3.5 Remove all debris from the basin before installing pumps.

3.6 The pumps have either 1¼", 1½" or 2" internally threaded discharge connection. Depending on the installation requirements, steel, stainless steel, or plastic pipe may be used to plumb the pump. Whichever is used, a free-flow check valve should be installed in the discharge line to prevent back flow. A union should also be installed in the line to facilitate pump removal. A shut-off valve (gate or ball type) should be installed above the check valve and union. See Figure 1 for a typical installation diagram. The pump may be suspended from the piping, but under no circumstances should the pump be required to support the weight of the piping.

### 4.0 INITIAL START UP

4.1 **Rotation.** Check to be sure the impeller is spinning in the proper direction before final installation of the pump. This is especially important with three phase pumps. The proper rotation is shown with an arrow on the top of the pump. Proper rotation is clock- wise when viewed from the

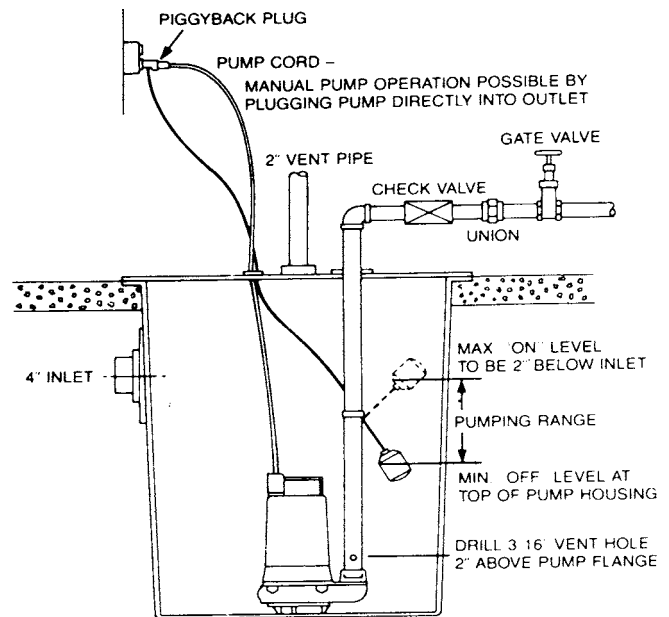

Figure 1

top of the pump. Often the easiest method for determining rotation is the "Start Reaction" method. To check rotation this way, place the pump standing upright on the floor. Momentarily energize the power and watch the direction the pump body twists. This twist or "start reaction" will be in a direction opposite to the impeller rotation. The start reaction should twist the pump in a counter- clockwise direction when viewed from the top of the pump.

4.2 If the direction of rotation of a three phase pump is incorrect, exchange any two of the motor input power leads at the power supply. This will reverse the rotation. Re-check pump for proper rotation after exchanging leads. If there are multiple pumps in the wet well, check rotation on each pump individually. Consult the factory immediately if a single phase pump runs backwards.

4.3 Run the pump under normal load, and check the motor amp draw with a clamp-on ammeter. Amp draw should be within the limits stated on the pump nameplate.

## 5.0 FLOATS AND CONTROLS

### WARNING: Piggyback Floats are for single ~ phase only.

5.1 The pump may be operated automatically using a piggyback float switch. This is a float switch whose cord has a special plug on the end. The float plug can be plugged into the electrical outlet, and the pump can then be plugged into the float plug. The float then cycles the pump on and off as the liquid level rises and falls.

#### Pumping Range Table for Single Piggyback Float

CABLE LENGTH FROM MOUNTING CLAMP TO FLOAT	PUMPING RANGE
3.5"	6.5"
5.0"	8.0"
7.0"	10.0"
9.0"	12.0"
11.0"	13.0"
13.0"	14.0"
15.0"	15.0"
17.0"	16.0"

5.2 **Single Piggyback Float.** To install a single piggyback float, first determine the pumping range from the Pumping Range Table. Attach the float cable to the float clamp using instructions and parts supplied with the float switch. Attach the float clamp to the discharge pipe as shown in Figure 2. Plug the float switch into the electrical outlet, and the pump into the back of the float plug. Fill the basin with liquid and adjust the height of the clamp, and float cable length to achieve desired pumping range.

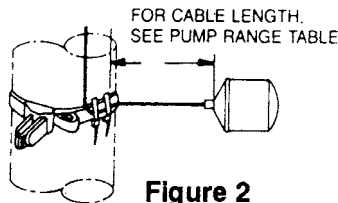

Figure 2

5.3 **Double Piggyback Float.** Double piggyback floats are used where large distances between on and off levels are required. Setup of the float switches is the same as described in 5.2 above, except the pumping range is controlled by the vertical distance between the "on" and "off" floats. Consult the instructions supplied with the floats to determine which is the "on" and which is the "off" float.

5.4 **Pilot Floats With Control Panel.** The pump may be operated off a control panel in either a simplex or duplex configuration. When a control panel is used, pilot floats signal the control panel when to turn pumps on and off. A typical duplex station is shown in Figure 3. The pumping range is controlled by the vertical distance between the "on" or "lead" float, and the "off" float. In a duplex station, the "lag" float brings on the second pump in the event the level continues to rise after the lead pump has come on. The lag float is sometimes tied into the high level alarm system to sound an alarm.

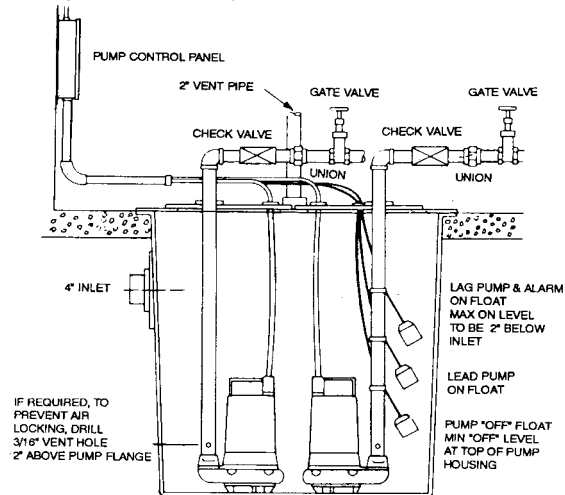

Figure 3

## 6.0 PERIODIC MAINTENANCE

6.1 **Disconnect all electric power from the system before performing maintenance on any pump, float, or control.**

6.2 **Never lift the pump by its power cord.**

6.3 **Pump Wash down.** The accumulation of grease, sludge, or crust on the exterior of the pump housing interferes with the transfer of normal motor heat to the pumped fluid. This may result in overheating of the motor, and shortening of the motor's life. Pumps should be cleaned at intervals appropriate for the conditions they are operating in. Generally a six month interval is acceptable. Use caution not to damage the pump power cord during cleaning. If the power cord should become damaged, remove the pump from service immediately.

6.4 **Float Switch Cleaning.** Accumulation of grease, sludge, or crust on float switches may interfere with the proper operation of the floats. Floats should be checked at three month intervals, and cleaned as required. Use caution not to damage the float cord during cleaning. Never use a float with a damaged cord.

# ONE YEAR WARRANTY

ABS Pumps Inc. warrants the above series of submersible pumps to be free from defect in workmanship and materials for a period of one (1) year after date of shipment to end customer.

Start-up reports and electrical systems schematics may be required to support warranty claims. Warranty effective only if Company supplied or authorized control panels are used.

The Company's sole obligation under this warranty shall be to make repairs and replace parts when necessary on products that have been returned to it or to an authorized service facility and found to be defective by the Company. The Company shall not be liable for any special, indirect, or consequential damages of any kind. Major components not manufactured by the Company are covered by the original manufacturer's warranty in lieu of this warranty. The Company will not be held responsible for travel expenses, rented equipment, outside contractors fees, or unauthorized repair shop expenses. The Company neither assumes nor authorizes any person or other company to assume for it, any other obligation in connection with the sale of its equipment. Any enlargement or modification of this warranty by the Representative or other Sales Agent is their exclusive responsibility. Transportation charges shall be borne by the Buyer. Returns must have prior written authorization from the Company.

This warranty shall extend only to the original Owner and shall not apply to any product that have been repaired or altered without the Company's consent or have been subject to misuse, accident or neglect, or have been used for pumping materials which are incompatible with the materials of construction of the pump.

**NO OTHER WARRANTIES EXPRESS OR IMPLIED, INCLUDING IMPLIED WARRANTIES OF MERCHANTABILITY AND FITNESS FOR A PARTICULAR PURPOSE WILL APPLY.**

## TROUBLESHOOTING CHART

SYMPTOM	PROBABLE CAUSE	REMEDY
(1) Pump will not start	(1) Level switch failure  (2) Power supply failure  (3) Burned out fuse or tripped circuit breaker (4) Damaged power cable (5) Jammed impeller (6) Water inside motor (7) Foreign matter build-up	(1) Remove pump plug from piggyback and plug directly in outlet. If pump runs, replace level switch (es). If floats are connected to power supply, check float switches per symptoms 3 through 7.  (2) a. Check power supply b. Check electrical system for loose connections. c. Check operating voltage between terminals L1 and L2, single phase. d. Check operating voltage between any two lines, three phase. (3) Check circuit protectors, reset circuit breakers. (4) Check external cable for damage. (5) Inspect and remove jamming object. (6) Contact factory. (7) Clean floats carefully.
(2) Repeated tripping*	(1) Circuit protection underrated (2) Pump connected to incorrect voltage (3) Wet or damaged wiring (4) Obstruction in pump (5) Pump rotation	(1) Check rating and replace with proper size. (2) Verify connections; see specific wiring diagram. (3) Inspect external cable and replace if worn or damaged. (4) Remove obstruction. (5) Check pump rotation if three phase.
<b>*IF SYMPTOMS CONTINUE, CONSULT FACTORY</b>		
(3) Pump runs in manual, not in automatic	(1) Bad "OFF" float switch  (2) Bad "ON" float switch	(1) Install wire jumper between "OFF" switch terminals. If pump starts to run, replace the "OFF" switch.  (2) Install wire jumper between "ON" float terminals. If pump starts to run, replace the "ON" float switch.
(4) Pumps run separately, but not together (duplex operation)	(1) Faulty lead pump float switch (2) Faulty lag pump float switch (3) Foreign matter build-up on floats	(1) With power off, invert each float switch to check leads for continuity. (2) Same as remedy (1). (3) Clean floats.
(5) Pump will not shut off	(1) Level switch failure (2) Level control panel failure	(1) With power off, check float switches for continuity. (2) Check control panel schematic drawing.
(6) High level alarm does not come on (optional)	(1) Faulty high level alarm float switch	(1) Install wire jumper between alarm terminals. (2) Replace high level alarm float switch.
(7) Low flow	(1) Pump rotation (2) Liquid level in pit too low-air bound (3) Obstruction in pump or piping (4) Partially closed valve(s)	(1) Check pump rotation. (2) Check liquid level and location of level switches. (3) Remove obstruction. (4) Check and adjust valve(s).



140 Pond View Drive, Meriden, Connecticut 06450. (203) 238-2700. FAX (203) 238-0738 [www.abspumpsusa.com](http://www.abspumpsusa.com)  
 ABS Pumps Ltd. . Clonard Road . Wexford , Ireland . Telephone ( 053 ) 63200 . Fax (053) 42335 [www.abspumps.com](http://www.abspumps.com)