

## Instruction Manual

PN 51-247/rev.A

September 2002

# Model 247

Economy Toroidal Conductivity Sensor



## ESSENTIAL INSTRUCTIONS

### READ THIS PAGE BEFORE PROCEEDING!

Rosemount Analytical designs, manufactures, and tests its products to meet many national and international standards. Because these instruments are sophisticated technical products, you must properly install, use, and maintain them to ensure they continue to operate within their normal specifications. The following instructions must be adhered to and integrated into your safety program when installing, using, and maintaining Rosemount Analytical products. Failure to follow the proper instructions may cause any one of the following situations to occur: Loss of life; personal injury; property damage; damage to this instrument; and warranty invalidation.

- Read all instructions prior to installing, operating, and servicing the product. If this Instruction Manual is not the correct manual, telephone 1-800-654-7768 and the requested manual will be provided. Save this Instruction Manual for future reference.
- If you do not understand any of the instructions, contact your Rosemount representative for clarification.
- Follow all warnings, cautions, and instructions marked on and supplied with the product.
- Inform and educate your personnel in the proper installation, operation, and maintenance of the product.
- Install your equipment as specified in the Installation Instructions of the appropriate Instruction Manual and per applicable local and national codes. Connect all products to the proper electrical and pressure sources.
- To ensure proper performance, use qualified personnel to install, operate, update, program, and maintain the product.
- When replacement parts are required, ensure that qualified people use replacement parts specified by Rosemount. Unauthorized parts and procedures can affect the product's performance and place the safe operation of your process at risk. Look alike substitutions may result in fire, electrical hazards, or improper operation.
- Ensure that all equipment doors are closed and protective covers are in place, except when maintenance is being performed by qualified persons, to prevent electrical shock and personal injury.

## DANGER

### HAZARDOUS AREA INSTALLATION

Installations near flammable liquids or in hazardous area locations must be carefully evaluated by qualified on site safety personnel. This sensor is not Intrinsically Safe or Explosion Proof.

To secure and maintain an intrinsically safe installation, the certified safety barrier, transmitter, and sensor combination must be used. The installation system must comply with the governing approval agency (FM, CSA or BASEEFA/CENELEC) hazardous area classification requirements. Consult your analyzer/transmitter instruction manual for details.

Proper installation, operation and servicing of this sensor in a Hazardous Area Installation is entirely the responsibility of the user.

## CAUTION

### SENSOR/PROCESS APPLICATION COMPATIBILITY

**The wetted sensor materials may not be compatible with process composition and operating conditions. Application compatibility is entirely the responsibility of the user.**



## CAUTION



**BEFORE REMOVING THE SENSOR, be absolutely certain the process pressure is reduced to 0 psig and the process temperature is at a safe level!**

**Pollardwater** dot com

Phone 800-437-1146  
Fax 425-861-7235  
[info@pollardwater.com](mailto:info@pollardwater.com)

**West Coast Branch**  
17515 NE 67<sup>th</sup> Ct  
Redmond, WA 98052

**East Coast Branch**  
200 Atlantic Ave  
New Hyde Park, NY 11040



**EMERSON**  
Process Management

# MODEL 247 ECONOMY TOROIDAL CONDUCTIVITY SENSOR

## TABLE OF CONTENTS

Section	Title	Page
<b>1.0</b>	<b>MODEL 247 SENSOR</b> .....	<b>1</b>
1.1	General .....	1
1.2	Specifications .....	1
1.3	Ordering Information .....	2
1.4	Accessories.....	2
1.5	Sensor Installation .....	3
1.6	Sensor Wiring .....	5
1.7	Sensor Calibration .....	7
1.8	Sensor Maintenance .....	7
1.9	Troubleshooting .....	7
<b>2.0</b>	<b>RETURN OF MATERIAL</b> .....	<b>9</b>

## LIST OF TABLES

Table No.	Title	Page
1-1	Specifications: Sensor .....	1
1-2	Specifications: Adapters .....	1
1-3	Sensor Resistance Check .....	8
1-4	Resistance vs. Temperature .....	8

**TABLE OF CONTENTS (CONTINUED)**

**LIST OF FIGURES**

<b>Figure No.</b>	<b>Title</b>	<b>Page</b>
1-1	Sensor Dimensions.....	2
1-2	Model 247 with Mounting Adapter: Kit 23986-00 .....	3
1-3	Model 247 with CPVC Union: Kit 23986-01 .....	3
1-4	Model 247 in Custom Flow-Tee: Kit 23986-02 .....	4
1-5	Wire Functions.....	5
1-6	Wiring to Model 1055-10-21-31 .....	5
1-7	Wiring to Model 1055-11-21-31 .....	6

## SECTION 1.0

# MODEL 247 SENSOR

### 1.1 GENERAL.

Rosemount Analytical Toroidal Conductivity Sensors are ideal for use in processes where conventional sensors -- those with electrodes exposed to the measured solution -- would corrode or become fouled.

The Model 247 Economy Toroidal Conductivity Sensor consists of wire-wound toroids that are isolated from the process. One toroid acts as a transmitter and the other as a receiver. Energizing the transmitter toroid induces an electric current into the process solution which induces an electric current into the receiver toroid. The strength of that induced current is directly proportional to the conductivity of the solution.

The Model 247 sensor is constructed with a solvent-welded CPVC body which makes it durable and chemically resistant to most dilute acids, bases, and inorganic salt solutions. The sensor's integral Pt 100 RTD ensures accurate temperature compensation.

The Model 247 sensor is easy to install. The toroidal sensor is not sensitive to flow rate or direction. It can be installed using PVC\* fittings readily available at local hardware stores or with CPVC fittings offered here as accessories.

All these features make the sensor ideal for applying to **cooling water treatment, boiler blowdown, and metal plating** processes.

The Model 247 CPVC Toroidal Conductivity Sensor is compatible with Rosemount Analytical instrument Model 1055-21 or -31.

*\*Carefully check the manufacturer's pressure and temperature limits for any adapters not supplied by Rosemount Analytical. PVC adapters typically have lower pressure and temperature ratings than those specified here for CPVC.*

### 1.2 SPECIFICATIONS

TABLE 1-1. Sensor

<b>Installation Type</b>	Submersion, Flow-Tee
<b>Conductivity Range</b>	500 microSiemen/cm to 1 Siemen/cm
<b>Maximum Temperature</b>	165°F (75°C)
<b>Maximum Pressure</b>	100 psig (790 kPa abs)
<b>Wetted Materials</b>	CPVC
<b>Shipping Weight</b>	1.9 lbs (0.9 kg)

TABLE 1-2. Adapters

MODEL	Description	Materials of Construction	Temperature	Pressure
23986-00	Mounting Adapter, 1" slip x 1" MPT	CPVC	165°F (75°C)	100 psig (790 kPa abs)
23986-01	Union, 1" slip x 1" slip	CPVC, Viton®	165°F (75°C)	100 psig (790 kPa abs)
23986-02	Tee, Flow-through, 2" with slip union	CPVC, Viton®	150°F (66°C)	100 psig (790 kPa abs)

® Viton is a registered trademark of DuPont Dow Elastomers.

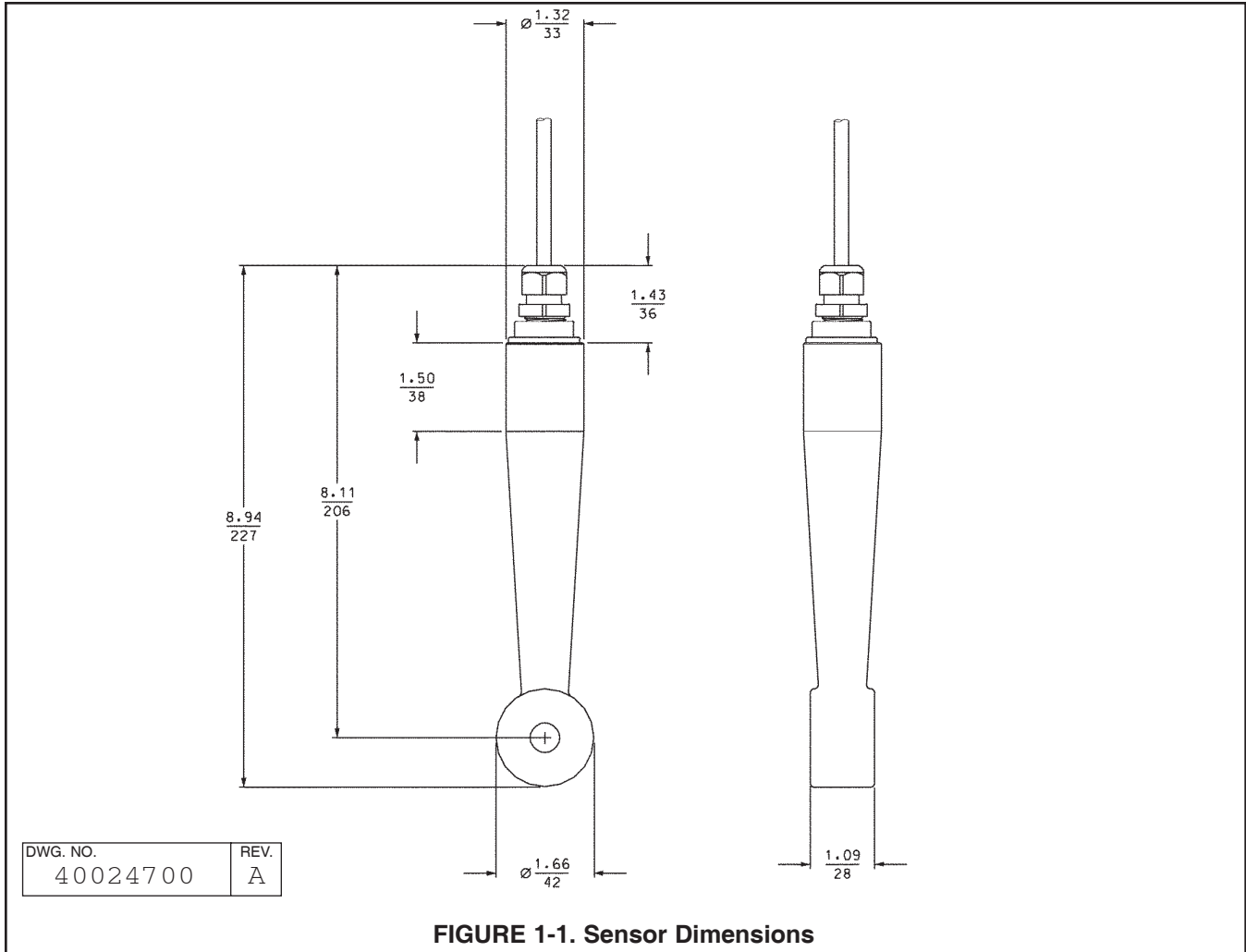

### 1.3 ORDERING INFORMATION

The Model 247 Economy Conductivity Sensor is constructed with a CPVC body and includes an integral Pt 100 RTD and a 20' cable. The back end fits into standard 1" plumbing fittings. The sensor can be installed in the process via submersion using either the CPVC fittings (sold separately) or more commonly available PVC\* fittings. For flow-tee installation, the custom-made 2" CPVC Tee kit sold below is required. The sensor is compatible with instrument Model 1055.

MODEL	DESCRIPTION
247	CPVC Toroidal Sensor

### 1.4 ACCESSORIES

PN	DESCRIPTION
23986-00	Mounting Adapter, CPVC, 1" slip x 1" MPT
23986-01	Union, CPVC, 1" slip x 1" slip
23986-02	Tee, Flow-through, 2" CPVC with slip union (custom)

\*Carefully check the manufacturer's pressure and temperature limits for any adapters not supplied by Rosemount Analytical. PVC adapters typically have lower pressure and temperature ratings than those specified here for CPVC.

### 1.5 SENSOR INSTALLATION

Using good plumbing practices, solvent bond the sensor into the chosen mounting adapters. Keep at least 1 inch (2.5 cm) separation between the sensor and the surrounding vessel walls. If clearance is too small, standardize the sensor in place. Ensure that the sensor is completely submerged in the liquid.

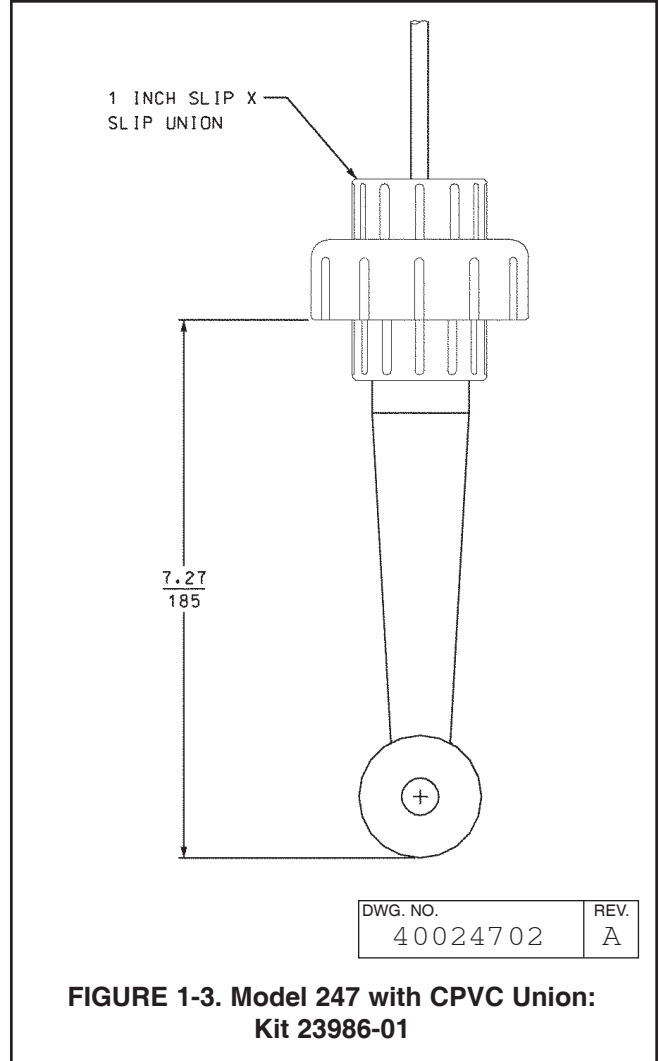
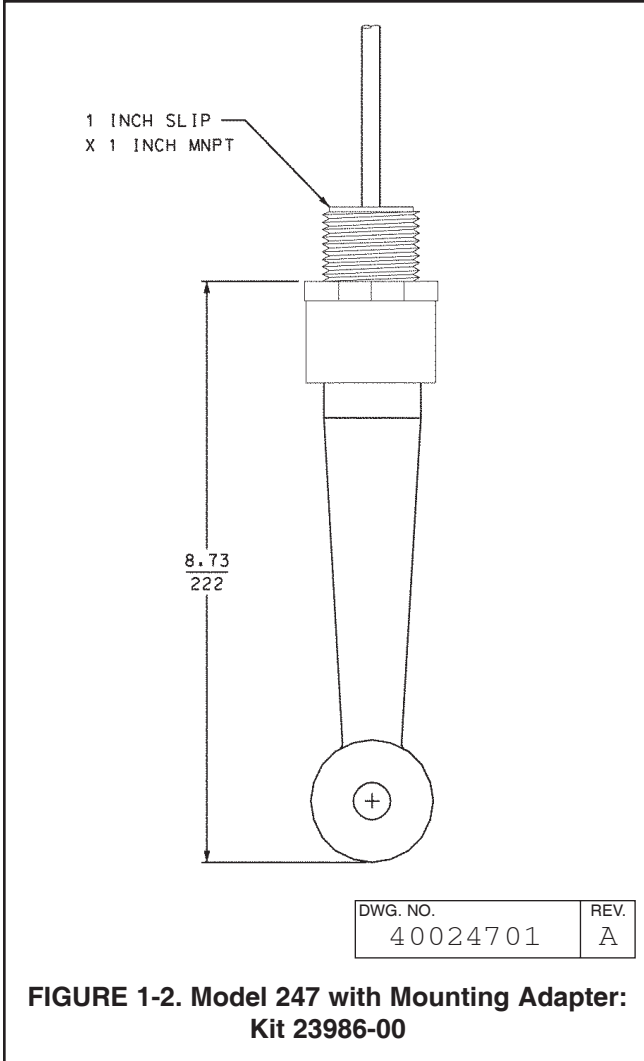

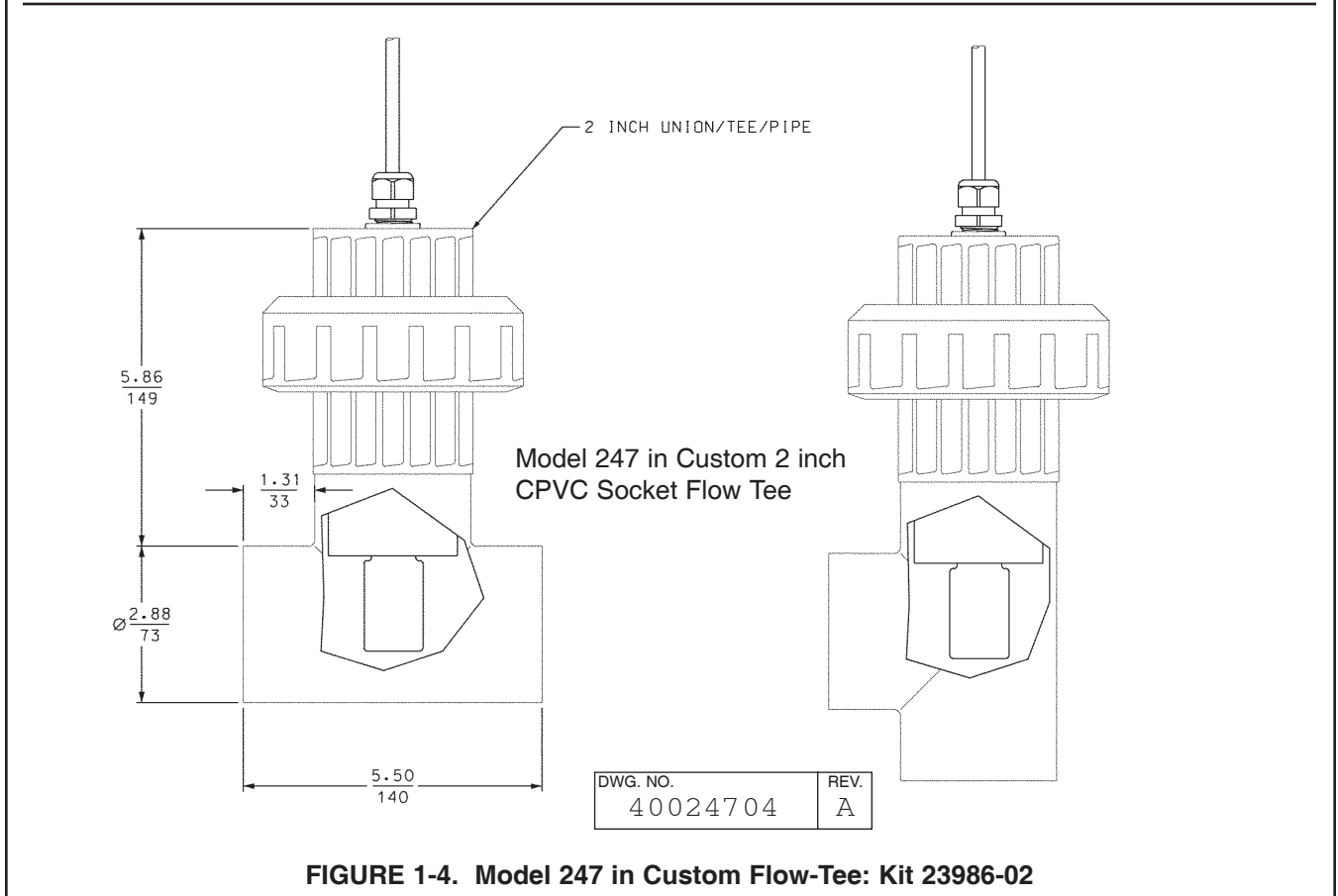
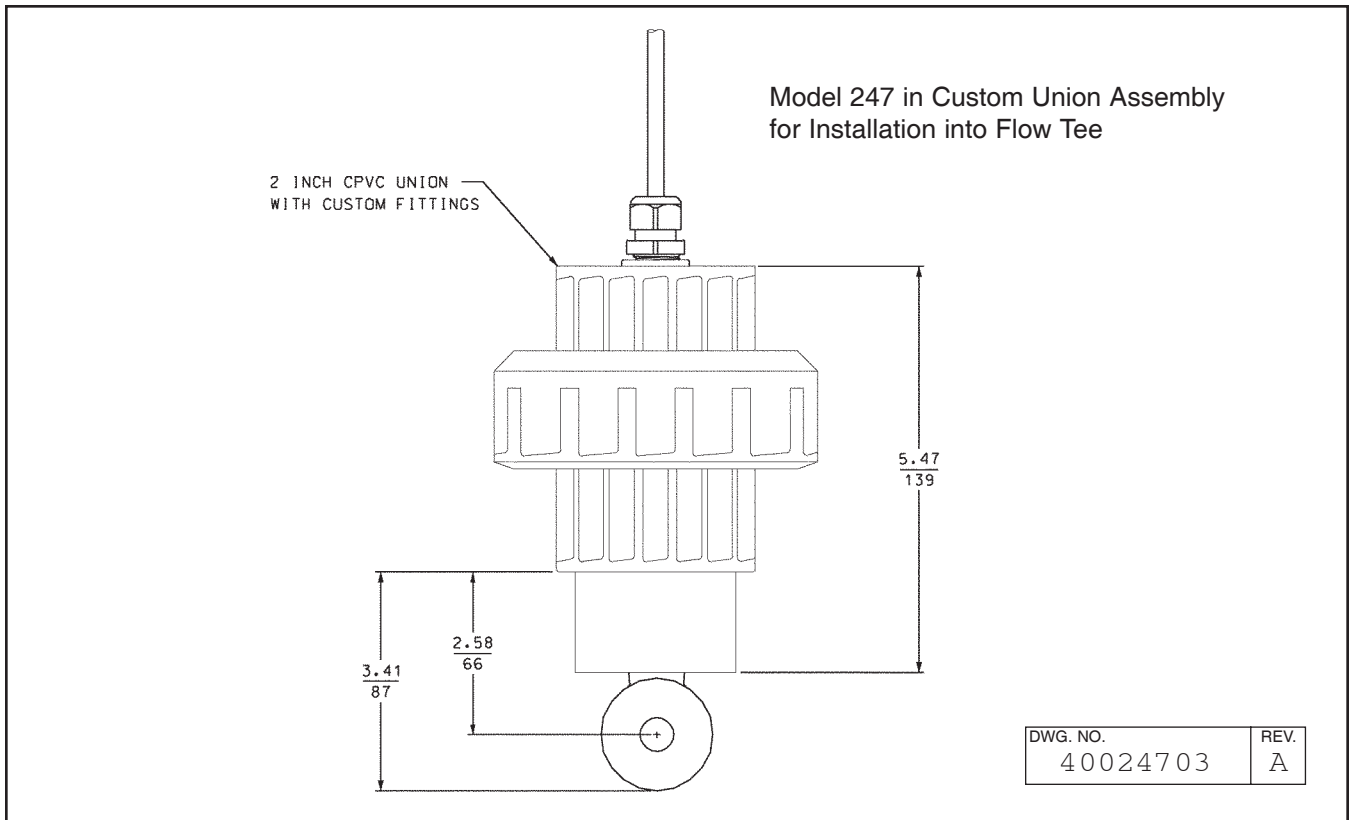

FIGURE 1-4. Model 247 in Custom Flow-Tee: Kit 23986-02

### 1.6 SENSOR WIRING.

Sensor cable should not be run in conduit nor open trays with any A.C. power wiring, nor routed close to high current demanding electrical equipment.

If conduit is used, the connections should be sealed or plugged using sealing compound to avoid accumulation of moisture in the instrument housing.

Do not cut cable.

Refer to Figure 1-5 for the functions of the wires of the Model 247 sensor. To connect the sensor to the Model 1055 instruments, refer to Figures 1-6 and 1-7.

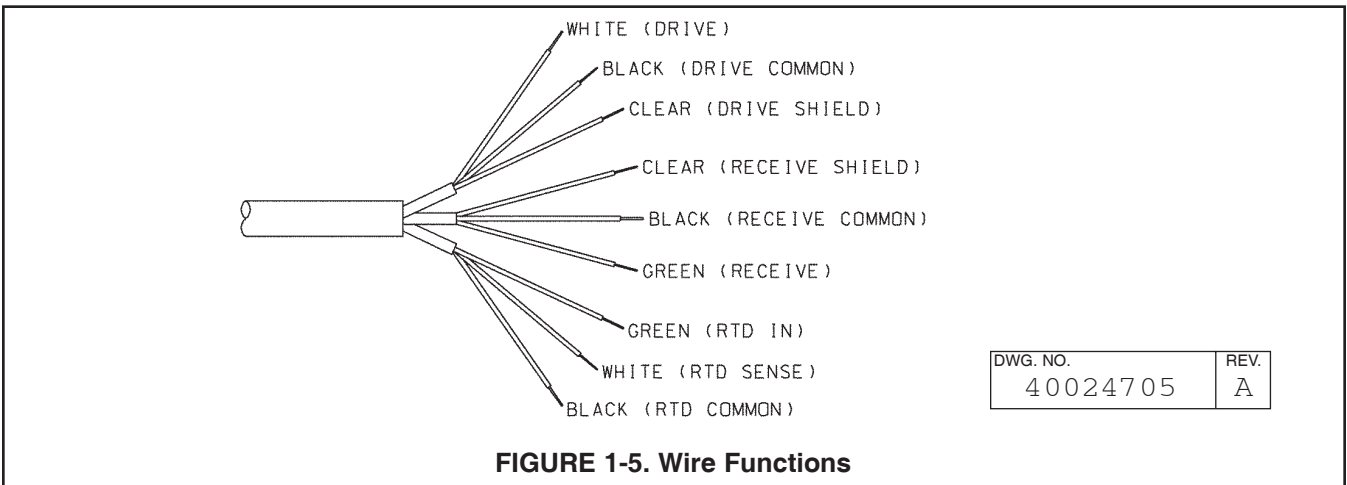

FIGURE 1-5. Wire Functions

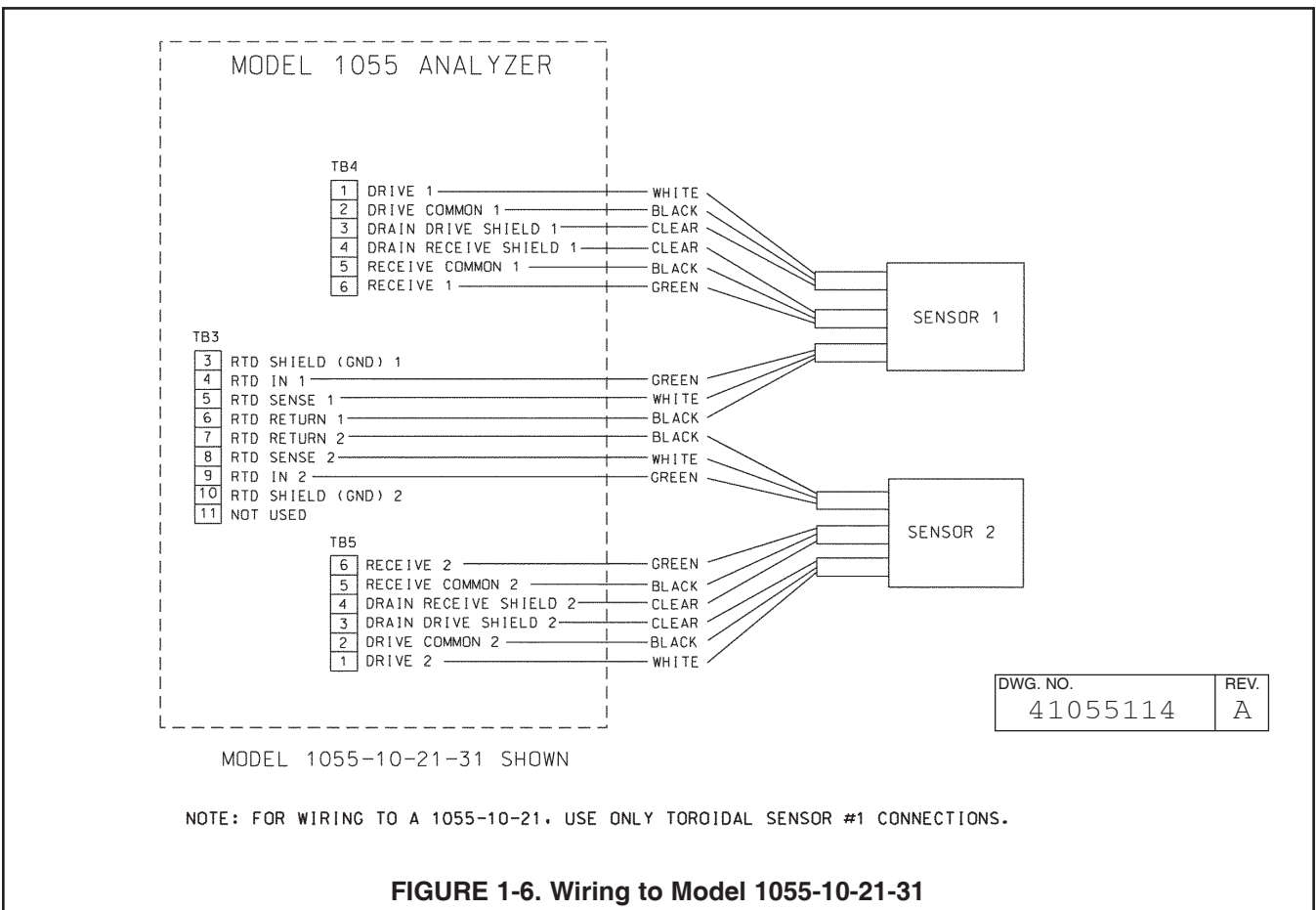
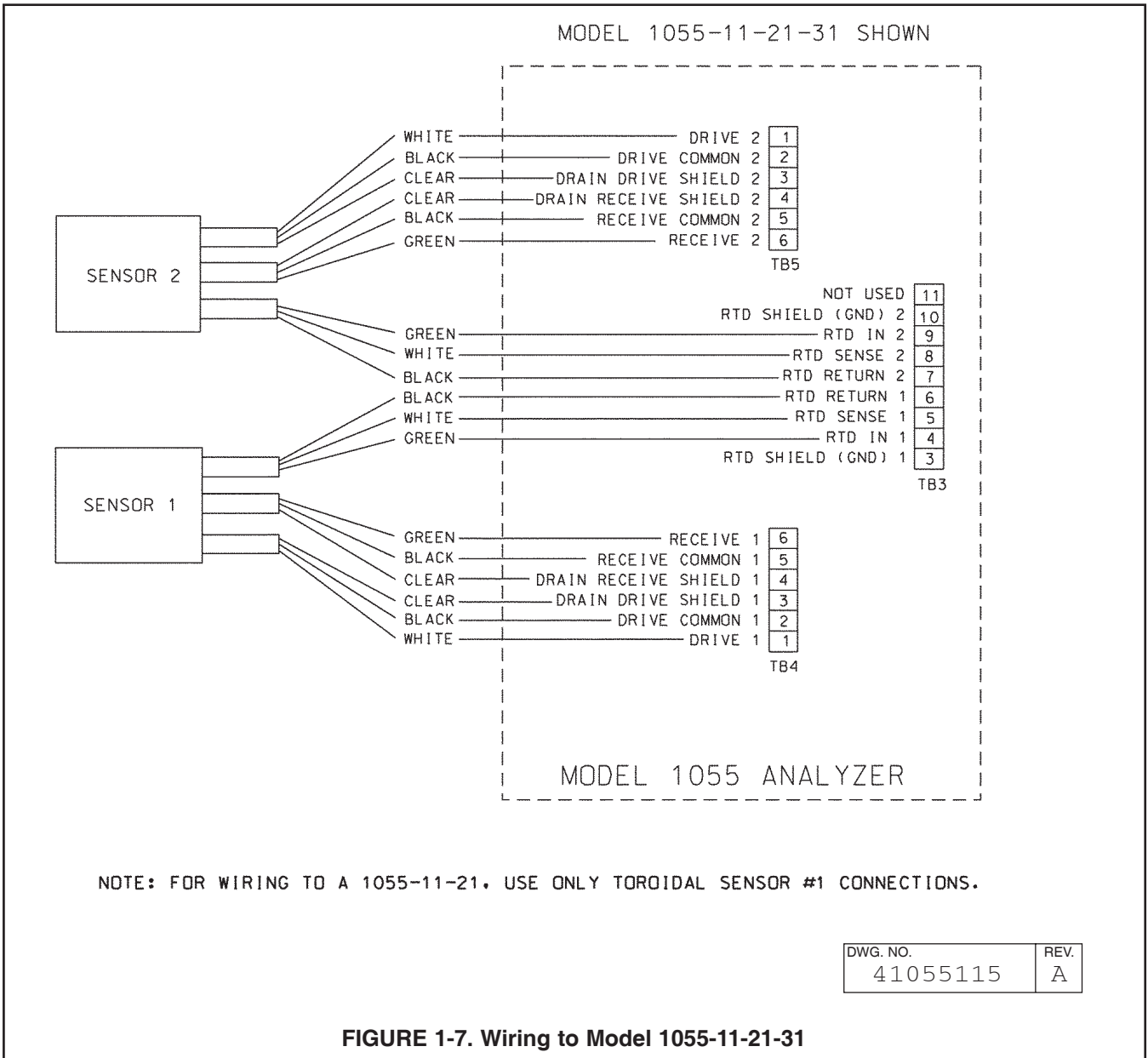

FIGURE 1-6. Wiring to Model 1055-10-21-31



**FIGURE 1-7. Wiring to Model 1055-11-21-31**

## 1.7 SENSOR CALIBRATION.

After sensor and instrument wiring is completed, calibration and slope adjustment should be performed prior to field installation. The appropriate instrument manual should be consulted for this procedure.

The sensor can be calibrated using a known standard conductivity solution at 25°C, but the calibration arrangement should approximate the mounting arrangement. If the sensor is to be used in a submersion application, the calibration should be performed in a very large glass beaker or large plastic container, with all sides of the sensor at least one inch away from the walls of the beaker. If the sensor is to be inserted in a tee for flow through applications using the adapter, it should be calibrated in line using a grab sample.

When submersing the sensor in the calibration solution, it is extremely important to make sure that there is no possibility that air could be trapped in the bore of the sensor. This can be done by submersing the sensor at an angle and dislodging the air bubble.

The mounting arrangement used during calibration should approximate the final process mounting configuration because the current path of the sensor (and thus the cell constant) is affected by the immediate environment of the sensor. During calibration, if the sensor is placed within approximately one inch of an insulating material like glass or plastic, the current path area of the sensor is reduced, thus increasing the sensor cell constant and reducing the conductivity reading. If the sensor is placed within approximately one inch of a conductive material like metal, the current path of the sensor is "shorted out" in that direction, and the conductivity reading is increased because it is partly based on the conductance of the metal.

If a very accurate reading is required, such as in the case of a very low conductivity system, a special calibration should be performed by standardizing the loop at or very near the temperature and conductivity of the process being measured. This should be done in addition to the procedure described above, so that the mounting configuration is approximated as closely as possible. By following these three calibration steps, the tolerance (or error) introduced by the sensor should be reduced to less than  $\pm 20 \mu\text{S/cm}$ . This sensor-induced error should be added to any instrument-induced error to formulate expectations of total loop performance.

## 1.8 SENSOR MAINTENANCE

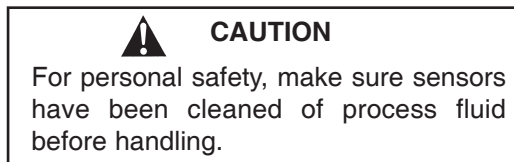

The only maintenance required during the normal operational life of the sensor is to ensure that there are no deposits blocking the opening of the sensor.

## 1.9 TROUBLESHOOTING.

Please refer to Sensor Resistance Check Table 1-3 and Temperature vs. Resistance Table 1-4.

### CABLE WARNING

**The Model 247 warranty may become void if the cable is cut.** The purpose of this warning is to advise that incorrect cable termination will result in signal noise and an unstable zero. This special low-noise cable requires attention to detail to terminate correctly. If there is no alternative to cutting the cable, it is recommended that the sensor be returned to Rosemount Analytical, Irvine, where the cable termination will be performed for a nominal charge.

<b>TABLE 1-3. Sensor Resistance Check</b>	
<b>WIRE</b>	<b>RESISTANCE</b>
(1) WHITE (DRIVE) —————	1 TO 2 OHMS > 20 MEGOHMS (OPEN)
(2) BLACK (DRIVE COMMON) —————	
(3) CLEAR (DRIVE SHIELD) —————	
(4) GREEN (RECEIVE) —————	1 TO 2 OHMS > 20 MEGOHMS (OPEN)
(5) BLACK (RECEIVE COMMON) —————	
(6) CLEAR (RECEIVE SHIELD) —————	
(7) GREEN (RTD IN) —————	109.6 OHMS** LESS THAN 2 OHMS
(8) BLACK (RTD COMMON) —————	
(9) WHITE (RTD SENSE) —————	

\*\* Resistance listed is for TC value at 25°C (77°F) (see TABLE 1-4 for other temperature values).

<b>TABLE 1-4. Resistance vs. Temperature for Temperature Compensation (Resistance Temperature Detector)</b>		
<b>RTD Type</b>	<b>Temperature (°C/°F)</b>	<b>Resistance (Ohms)</b>
<b>100 ohm RTD</b>	<b>18/64.4</b>	<b>106.9</b>
	<b>19/66.2</b>	<b>107.3</b>
	<b>20/68.0</b>	<b>107.7</b>
	<b>21/69.8</b>	<b>108.1</b>
	<b>22/71.6</b>	<b>108.4</b>
	<b>23/73.4</b>	<b>108.9</b>
	<b>24/75.2</b>	<b>109.2</b>
	<b>25/77.0</b>	<b>109.6</b>
	<b>26/78.8</b>	<b>110.0</b>
	<b>27/80.6</b>	<b>110.4</b>

## SECTION 2.0 RETURN OF MATERIAL

**2.1 GENERAL.** To expedite the repair and return of instruments, proper communication between the customer and the factory is important. A return material authorization (RMA) number is required. Call (949) 757-8500. The "Return of Materials Request" form is provided for you to copy and use in case the situation arises. The accuracy and completeness of this form will affect the processing time of your materials.

**2.2 WARRANTY REPAIR.** The following is the procedure for returning instruments still under warranty.

1. Contact the factory for authorization.
2. Complete a copy of the "Return of Materials Request" form as completely and accurately as possible.
3. To verify warranty, supply the factory sales order number or the original purchase order number. In the case of individual parts or sub-assemblies, the serial number on the mother unit must be supplied.
4. Carefully package the materials and enclose your "Letter of Transmittal" and the completed copy of the "Return of Materials Request" form. If possible, pack the materials in the same manner as it was received.

### IMPORTANT

Please see second section of "Return of Materials Request Form". Compliance to the OSHA requirements is mandatory for the safety of all personnel. MSDS forms and a certification that the instruments have been disinfected or detoxified are required.

5. Send the package prepaid to:

Rosemount Analytical Inc.  
2400 Barranca Parkway  
Irvine, CA 92606

Attn: Factory Repair

Mark the package: Returned for Repair

RMA# \_\_\_\_\_

Model No. \_\_\_\_\_

### 2.3 NON WARRANTY REPAIR.

1. Contact the factory for authorization.
2. Fill out a copy of the "Return of Materials Request" form as completely and accurately as possible.
3. Include a purchase order number and make sure to include the name and telephone number of the right individual to be contacted should additional information be needed.
4. Do Steps 4 and 5 of Section 2.2.

### NOTE

Consult the factory for additional information regarding service or repair.



## WARRANTY

Seller warrants that the firmware will execute the programming instructions provided by Seller, and that the Goods manufactured or Services provided by Seller will be free from defects in materials or workmanship under normal use and care until the expiration of the applicable warranty period. Goods are warranted for twelve (12) months from the date of initial installation or eighteen (18) months from the date of shipment by Seller, whichever period expires first. **Consumables, such as glass electrodes, membranes, liquid junctions, electrolyte, o-rings, catalytic beads, etc., and Services are warranted for a period of 90 days from the date of shipment or provision.**

Products purchased by Seller from a third party for resale to Buyer ("Resale Products") shall carry only the warranty extended by the original manufacturer. Buyer agrees that Seller has no liability for Resale Products beyond making a reasonable commercial effort to arrange for procurement and shipping of the Resale Products.

If Buyer discovers any warranty defects and notifies Seller thereof in writing during the applicable warranty period, Seller shall, at its option, promptly correct any errors that are found by Seller in the firmware or Services, or repair or replace F.O.B. point of manufacture that portion of the Goods or firmware found by Seller to be defective, or refund the purchase price of the defective portion of the Goods/Services.

All replacements or repairs necessitated by inadequate maintenance, normal wear and usage, unsuitable power sources, unsuitable environmental conditions, accident, misuse, improper installation, modification, repair, storage or handling, or any other cause not the fault of Seller are not covered by this limited warranty, and shall be at Buyer's expense. Seller shall not be obligated to pay any costs or charges incurred by Buyer or any other party except as may be agreed upon in writing in advance by an authorized Seller representative. All costs of dismantling, reinstallation and freight and the time and expenses of Seller's personnel for site travel and diagnosis under this warranty clause shall be borne by Buyer unless accepted in writing by Seller.

Goods repaired and parts replaced during the warranty period shall be in warranty for the remainder of the original warranty period or ninety (90) days, whichever is longer. This limited warranty is the only warranty made by Seller and can be amended only in a writing signed by an authorized representative of Seller. Except as otherwise expressly provided in the Agreement, THERE ARE NO REPRESENTATIONS OR WARRANTIES OF ANY KIND, EXPRESS OR IMPLIED, AS TO MERCHANTABILITY, FITNESS FOR PARTICULAR PURPOSE, OR ANY OTHER MATTER WITH RESPECT TO ANY OF THE GOODS OR SERVICES.

## RETURN OF MATERIAL

Material returned for repair, whether in or out of warranty, should be shipped prepaid to:

**Emerson Process Management  
Liquid Division  
2400 Barranca Parkway  
Irvine, CA 92606**

The shipping container should be marked:

Return for Repair

Model \_\_\_\_\_

The returned material should be accompanied by a letter of transmittal which should include the following information (make a copy of the "Return of Materials Request" found on the last page of the Manual and provide the following thereon):

1. Location type of service, and length of time of service of the device.
2. Description of the faulty operation of the device and the circumstances of the failure.
3. Name and telephone number of the person to contact if there are questions about the returned material.
4. Statement as to whether warranty or non-warranty service is requested.
5. Complete shipping instructions for return of the material.

Adherence to these procedures will expedite handling of the returned material and will prevent unnecessary additional charges for inspection and testing to determine the problem with the device.

If the material is returned for out-of-warranty repairs, a purchase order for repairs should be enclosed.



*The right people,  
the right answers,  
right now.*

ROSEMOUNT ANALYTICAL

ON-LINE ORDERING NOW AVAILABLE ON OUR WEB SITE  
<http://www.raihome.com>

*Specifications subject to change without notice.*

**Pollardwater** dot com

Phone 800-437-1146  
Fax 425-861-7235  
[info@pollardwater.com](mailto:info@pollardwater.com)

**West Coast Branch**  
17515 NE 67<sup>th</sup> Ct  
Redmond, WA 98052

**East Coast Branch**  
200 Atlantic Ave  
New Hyde Park, NY 11040

Credit Cards for U.S. Purchases Only.



**EMERSON**  
Process Management