

# Instruction Manual

PN 51-TCL1055/rev.B

February 2006

Model TCL

# Total Chlorine Analyzer



# **ESSENTIAL INSTRUCTIONS**

## **READ THIS PAGE BEFORE**

### **PROCEEDING!**

Rosemount Analytical designs, manufactures, and tests its products to meet many national and international standards. Because these instruments are sophisticated technical products, you must properly install, use, and maintain them to ensure they continue to operate within their normal specifications. The following instructions must be adhered to and integrated into your safety program when installing, using, and maintaining Rosemount Analytical products. Failure to follow the proper instructions may cause any one of the following situations to occur: Loss of life; personal injury; property damage; damage to this instrument; and warranty invalidation.

- Read all instructions prior to installing, operating, and servicing the product. If this Instruction Manual is not the correct manual, telephone 1-800-654-7768 and the requested manual will be provided. Save this Instruction Manual for future reference.
- If you do not understand any of the instructions, contact your Rosemount representative for clarification.
- Follow all warnings, cautions, and instructions marked on and supplied with the product.
- Inform and educate your personnel in the proper installation, operation, and maintenance of the product.
- Install your equipment as specified in the Installation Instructions of the appropriate Instruction Manual and per applicable local and national codes. Connect all products to the proper electrical and pressure sources.
- To ensure proper performance, use qualified personnel to install, operate, update, program, and maintain the product.
- When replacement parts are required, ensure that qualified people use replacement parts specified by Rosemount. Unauthorized parts and procedures can affect the product's performance and place the safe operation of your process at risk. Look alike substitutions may result in fire, electrical hazards, or improper operation.
- Ensure that all equipment doors are closed and protective covers are in place, except when maintenance is being performed by qualified persons, to prevent electrical shock and personal injury.

## **WARNING**

### **ELECTRICAL SHOCK HAZARD**

Making cable connections to and servicing this instrument require access to shock hazard level voltages which can cause death or serious injury.

Be sure to disconnect all hazardous voltage before opening the enclosure.

Relay contacts made to separate power sources must be disconnected before servicing.

Electrical installation must be in accordance with the National Electrical Code (ANSI/NFPA-70) and/or any other applicable national or local codes.

Unused cable conduit entries must be securely sealed by non-flammable closures to provide enclosure integrity in compliance with personal safety and environmental protection requirements.

The unused conduit openings need to be sealed with NEMA 4X or IP65 conduit plugs to maintain the ingress protection rating (IP65).

For safety and proper performance this instrument must be connected to a properly grounded three-wire power source.

Proper relay use and configuration is the responsibility of the user.

No external connection to the instrument of more than 69VDC or 43V peak allowed with the exception of power and relay terminals. Any violation will impair the safety protection provided

Do not operate this instrument without front cover secured. Refer installation, operation and servicing to qualified personnel.

## **WARNING**

This product is not intended for use in the light industrial, residential or commercial environment, per the instrument's certification to EN50081-2.

**Pollardwater**  **com**

Phone 800-437-1146  
Fax 425-861-7235  
[info@pollardwater.com](mailto:info@pollardwater.com)

**West Coast Branch**  
17515 NE 67<sup>th</sup> Ct  
Redmond, WA 98052

**East Coast Branch**  
200 Atlantic Ave  
New Hyde Park, NY 11040

 **WARNING**

 **HAZARDOUS VOLTAGE**

Can cause severe injury or death.  
Disconnect power before servicing.

 **VYSTRAHA**

 **NEBEZPECNE NAPETI**

Muze způsobit vážne zranení nebo smrt.  
Odpojte napájení před údržbou.

 **AVISO**

 **VOLTAJE PELIGROSO**

Puede causar severas lesiones o muerte.  
Desconecte la alimentación antes del mantenimiento.

 **ADVARSEL**

 **FARLIG SPÆNDING**

Kan forårsage alvorlige kvæstelser eller død.  
Afbryd spænding før servicering.

 **ATTENTION**

 **HAUTE TENSION**

Peut provoquer des blessures graves ou la mort.  
Déconnecter l'alimentation avant manipulation.

 **OSTRZEZENIE**

 **NIEBEZPIECZNE NAPIECIE**

Może spowodować uszkodzenie ciała lub śmierć. Odlacz zasilanie przed przystąpieniem do prac.

 **WARNING**

 **GEFAEHRLICHE SPANNUNG**

Am Gerät liegt eine gefährliche Spannung an. Schalten Sie immer vor dem Öffnen des Gerätes alle Zuleitungen spannungsfrei.

 **Waarschuwing**

 **GEVAARLIJKE SPANNING**

Kan ernstig of dodelijk letsel veroorzaken. Schakel de voeding uit voordat u onderhoudswerkzaamheden uitvoert.

 **Attenzione**

 **ALTA TENSIONE**

Può causare grave lesione o morte.  
Disattivare le tensioni prima di effettuare la manutenzione.

 **ADVARSEL**

 **FARLIG SPENNING**

Kan føre til alvorlige skader eller dødsulykker. Spenningstilførsel må frakobles før service utføres.

 **VARNING**

 **LIVSFARLIG SPÄNNING**

Kan medföra allvarlig skada eller dödsfall.  
Bryt spänning innan service utföres.

 **AVISO**

 **TENSÃO PERIGOSA**

Pode causar lesões graves ou a morte.  
Desligar a energia antes de proceder a trabalhos de manutenção.



## **DANGER**

### **HAZARDOUS AREA INSTALLATION**

Installations near flammable liquids or in hazardous area locations must be carefully evaluated by qualified on site safety personnel. This device is not Intrinsically Safe or Explosion Proof.

To secure and maintain an intrinsically safe installation, the certified safety barrier, transmitter, and sensor combination must be used. The installation system must comply with the governing approval agency (FM, CSA or BASEEFA/CENELEC) hazardous area classification requirements. Consult your analyzer/transmitter instruction manual for details.

Proper installation, operation and servicing of this device in a Hazardous Area Installation is entirely the responsibility of the user.



## **CAUTION**

### **SENSOR/PROCESS APPLICATION COMPATIBILITY**

**Wetted materials may not be compatible with process composition and operating conditions. Application compatibility is entirely the responsibility of the user.**

---

## **About This Document**

This manual contains instructions for installation and operation of the Model TCL Total Chlorine Analyzer.

The following list provides notes concerning all revisions of this document.

<b><u>Rev. Level</u></b>	<b><u>Date</u></b>	<b><u>Notes</u></b>
A	7/05	This is the initial release of the product manual. The manual has been reformatted to reflect the Emerson documentation style and updated to reflect any changes in the product offering.
B	2/06	Corrected typographical errors. Added statement to calibration section concerning initial stabilization time.

# MODEL TCL TOTAL CHLORINE ANALYZER

## TABLE OF CONTENTS

Section	Title	Page
<b>1.0</b>	<b>DESCRIPTION AND SPECIFICATIONS</b> .....	<b>1</b>
1.1	Features and Applications .....	2
1.2	Specifications — Sample Conditioning System .....	3
1.3	Specifications — Model 1055-24 Analyzer .....	3
1.4	Specifications — Model 499ACL-02 Sensor.....	4
1.5	Performance Specifications — Complete System .....	4
1.6	Ordering Information and Accessories .....	5
<b>2.0</b>	<b>PRINCIPLES OF OPERATION</b> .....	<b>7</b>
<b>3.0</b>	<b>INSTALLATION</b> .....	<b>8</b>
3.1	Unpacking and Inspection .....	8
3.2	Installation.....	8
<b>4.0</b>	<b>WIRING</b> .....	<b>14</b>
4.1	Prepare Analyzer Conduit Openings .....	14
4.2	Provide Power to the Sample Conditioning System .....	14
4.3	Make Power, Alarm, Output, and Sensor Connections in the Analyzer.....	15
4.4	Apply Power to the Analyzer and Complete Quick Start.....	16
<b>5.0</b>	<b>START-UP</b> .....	<b>17</b>
5.1	Start Sample Flow.....	17
5.2	Prepare the Reagent .....	17
5.3	Zero the Sensor.....	17
5.4	Begin Operation and Calibrate the Sensor.....	17
<b>6.0</b>	<b>DISPLAY AND OPERATION</b> .....	<b>18</b>
6.1	Display.....	18
6.2	Keypad.....	18
6.3	Programming and Calibrating the Solu Comp II — Tutorial.....	19
6.4	Security.....	20
6.5	Using Hold .....	20
<b>7.0</b>	<b>PROGRAMMING THE ANALYZER</b> .....	<b>21</b>
7.1	General.....	21
7.2	Changing Start-up Setting.....	21
7.3	Configuring and Ranging the Outputs .....	22
7.4	Configuring Alarms and Assigning Setpoints .....	24
7.5	Selecting the Type of Measurement .....	27
7.6	Choosing Temperature Units and Manual or Automatic Temperature Compensation .....	28
7.7	Setting a Security Code .....	29
7.8	Noise Rejection.....	29
7.9	Resetting Factory Calibration and Factory Default Settings.....	30
7.10	Selecting a Default Screen, Language, and Screen Contrast.....	31

## TABLE OF CONTENTS CONT'D.

<b>8.0</b>	<b>CALIBRATION .....</b>	<b>32</b>
8.1	Introduction .....	32
8.2	Calibrating Temperature .....	32
8.3	Calibration.....	34
<b>9.0</b>	<b>MAINTENANCE .....</b>	<b>39</b>
9.1	1055 Analyzer .....	39
9.2	Total Chlorine Sensor .....	41
9.3	Sample Conditioning System.....	43
<b>10.0</b>	<b>TROUBLESHOOTING .....</b>	<b>50</b>
10.1	Overview.....	50
10.2	Troubleshooting Using Fault Codes .....	50
10.3	Troubleshooting When No Error Message is Showing .....	51
10.4	Simulating Inputs .....	54
10.5	Simulating Temperature.....	55
<b>11.0</b>	<b>RETURN OF MATERIAL .....</b>	<b>56</b>

## LIST OF TABLES

Number	Title	Page
7-1	Default Settings .....	21
9-1	Replacement Parts for 1055 Analyzer (Panel Mount Version) .....	39
9-2	Replacement Parts for 1055 Analyzer (Wall Mount Version) .....	40
9-3	Spare Parts .....	42
9-4	Replacement Parts and Reagent for Sample Conditioning System .....	49

## LIST OF FIGURES

Number	Title	Page
2-1	Schematic of Sample Conditioning System and Analyzer .....	7
3-1	Panel Mount Installation .....	9
3-2	Pipe Mount Installation.....	10
3-3	Surface Mount Installation .....	11
3-4	Installing the Sample Conditioning Enclosure.....	12
3-5	TCL Case Dimensions .....	13
3-6	Reagent Tubing Assembly .....	13
4-1	Removing the Knockouts .....	14
4-2	Power Wiring.....	14
4-3	Wiring Connections for Model 1055-01-10 (Panel Mount with 115/230 Vac Power)	15
4-4	Wiring Connections for Model 1055-01-11 (Pipe/Surface Mount with 115/230 Vac Power) .	15
4-5	Chlorine sensor with Standard Cable.....	16
4-6	Chlorine sensor with Optimum EMI/RFI or Variopol Cable .....	16
6-1	Displays During Normal Operation .....	18
6-2	Solu Comp II Keypad .....	18
7-1	High Alarm Logic .....	24
7-2	Low Alarm Logic.....	24
8-1	Determination of Total Chlorine .....	34
8-2	Sensor Current as a Function of Total Chlorine Concentration.....	34
8-3	Dual Slope Calibration .....	37
9-1	Exploded View of 1055 Analyzer (Panel Mount Version) .....	39
9-2	Exploded View of 1055 Analyzer (Wall Mount Version) .....	40
9-3	Sensor Parts .....	42
9-4	Replacing Reagent Tubing.....	43
9-5	Replacing Sample Tubing .....	44
9-6	Replacing Peristaltic Pump Tubing — step 2.....	45
9-7	Replacing Peristaltic Pump Tubing — step 3.....	45
9-8	Replacing Peristaltic Pump Tubing — step 4.....	45
9-9	Replacing Peristaltic Pump Tubing — step 6.....	45
9-10	Replacing Peristaltic Pump Tubing — step 7a.....	46
9-11	Replacing Peristaltic Pump Tubing — step 7b.....	46
9-12	Replacing Peristaltic Pump Tubing — step 7c.....	46
9-13	Disconnecting Reagent and Air Injection Tubing .....	47
9-14	Air Pump Access Panel.....	47
9-15	Inlet and Discharge Tubing .....	47
9-16	Air Pump Wiring .....	47
9-17	Removing the Inlet Fitting .....	48
9-18	Pump Assembly .....	48
10-1	Disconnecting Sample and Reagent Tubing Prior to Checking Flow .....	53
10-2	Simulating Chlorine.....	54
10-3	Three-Wire RTD Configuration .....	55
10-4	Simulating RTD Inputs .....	55

## SECTION 1. DESCRIPTION AND SPECIFICATIONS

The Model TCL is intended for the determination of total chlorine in water, including the determination of chlorine in seawater. The system consists of a sample conditioning unit, a sensor, and a 1055-24 chlorine analyzer.

### Model TCL Sample Conditioning System

- **NO METAL WETTED PARTS.** Ideal for seawater.
- **LOW SAMPLE FLOW** (about 15 mL/minute) means little waste.
- **REAGENT-BASED SYSTEM** measures true total chlorine.
- **FIVE GALLONS OF REAGENT** lasts two months.

### Model 1055-24 Chlorine Analyzer

- **TWO LINE, BACK-LIT DISPLAY** with easy to use interface.
- **TWO INDEPENDENT OUTPUTS**
- **THREE FULLY PROGRAMMABLE ALARMS**
- **INPUT FILTER** improves stability at low concentrations.

### Model 499A CL-02 Sensor

- **MEMBRANE-COVERED AMPEROMETRIC SENSOR.**
- **NO TOOLS REQUIRED** to change membrane.
- **MAINTENANCE TAKES ONLY A FEW MINUTES** a month.
- **VARIOPOL CONNECTOR OPTION** allows the sensor to be replaced without removing and rewiring cable.

## 1.1 FEATURES AND APPLICATIONS

### MODEL 1055-24 SOLU COMP II CHLORINE ANALYZER

The Model 1055-24 Solu Comp II chlorine analyzer is designed for the continuous determination of chlorine in water. It is used with the Model 499ACL-02 sensor and the TCL sample conditioning system.

The Solu Comp II analyzer is housed in a weatherproof, corrosion-resistant, NEMA 4X enclosure. It is suitable for wall, panel, or pipe mounting. Operation of the analyzer is through a membrane keypad. A back lit, two-line display shows the total chlorine level as well as temperature. User-customized displays are available.

Menu screens for calibrating and programming are simple and intuitive. Plain language prompts in English, German, Italian, Portuguese, French, or Spanish guide the user through procedures. There are no service codes to enter. Information and diagnostic screens are available at the push of a button.

The Solu Comp II has two isolated, continuously variable 4-20 mA outputs. Outputs can be assigned to total chlorine concentration or to temperature. Output dampening and linear or logarithmic output are also available.

The Solu Comp II has three programmable alarm relays. Alarms can be assigned to total chlorine concentration or temperature. The third alarm can be configured as a fault alarm. The fault alarm activates when an analyzer or sensor fault occurs.

The analyzer fully compensates chlorine readings for changes in membrane permeability caused by temperature changes.

Solu Comp II Model 1055-24 for the determination of total chlorine is a single input instrument. The Solu Comp II is also available with dual input, for example, chlorine and pH. For additional information concerning the dual input option see Product Data Sheet (PDS 71-1055).

### MODEL 499A CL-02 SENSOR

The Model 499ACL-02 total chlorine sensor is used in the TCL sample conditioning system. Although the sensor is called a chlorine sensor, it really measures iodine. The iodine comes from the reaction between halogen oxidants in the sample and the acetic acid/potassium iodide reagent added by the sample conditioning system.

The sensor consists of a gold cathode and a silver anode in an electrolyte solution. A silicone membrane, permeable to iodine, is stretched over the cathode. The analyzer applies a voltage to the cathode sufficiently negative to reduce all the iodine reaching it. Because the concentration of iodine in the sensor is always zero, a concentration gradient continuously forces iodine from the sample through the membrane into the sensor.

The reduction of iodine in the sensor generates a current directly proportional to the diffusion rate of iodine through the membrane, which is directly proportional to the concentration of iodine in the sample. Because the iodine concentration depends on the amount of total chlorine in the sample, the sensor current is ultimately proportional to the total chlorine concentration.

The permeability of the membrane to iodine is a function of temperature. A Pt100 RTD in the sensor measures the temperature, and the analyzer uses the temperature to compensate the total chlorine reading for changes in membrane permeability.

Sensor maintenance is fast and easy. Replacing the membrane requires no special tools or fixtures. Simply place the membrane assembly on the cathode and screw the retainer in place. Installing a new membrane and replenishing the electrolyte takes only a few minutes.

### 1.2 SPECIFICATIONS — SAMPLE CONDITIONING SYSTEM

#### GENERAL

**Enclosure:** Fiberglass reinforced polyester, NEMA 3 (IP53) suitable for marine environments  
**Dimensions:** 14.5 x 13.0 x 8.6 in. (369 x 329 x 218 mm)  
**Mounting:** Wall  
**Ambient Temperature:** 32° - 122°F (0 - 50°C)  
**Ambient Humidity:** 0 - 90% (non-condensing)  
**Power:** 115 Vac, 6.9 W, 50/60 Hz;  
 230 Vac, 7.0 W, 50/60 Hz  
**Hazardous Location:** The TCL sample conditioning system has no hazardous location approvals.  
**Pumps:**   
 EN 809:1998  
**Weight/Shipping Weight:** 14 lb/16 lb (6.5 kg/7.5 kg)

#### SAMPLE REQUIREMENTS

**Inlet Connection:** compression fitting, accepts 1/4 in. OD tubing  
**Drain Connection:** 3/4 in. barbed fitting (must drain to open atmosphere)  
**Inlet Pressure:** <100 psig (791 kPa abs)  
**Flow:** at least 0.25 gph (15 mL/min)  
**Temperature:** 32 - 122°F (0 - 50°C)  
**Total Alkalinity:** <300 mg/L as CaCO<sub>3</sub>. For samples containing <50 mg/L alkalinity, consult the factory.

#### SAMPLE CONDITIONING SYSTEM

**Reagent:** Potassium iodide in vinegar.  
**Reagent Usage:** 5 gallons lasts approximately 60 days.  
**Reagent Pump:** Fixed speed peristaltic pump, about 0.2 mL/min  
**Sample Pump:** Fixed speed peristaltic pump, about 11 mL/min

### 1.3 SPECIFICATIONS — MODEL 1055-24 ANALYZER

**Case:** ABS. Pipe, surface, and panel mount versions are NEMA 4X/CSA 4 (IP65).  
**Dimensions**  
**Panel (code -10):** 6.10 x 6.10 x 3.72 in. (155 x 155 x 94.5 mm)  
**Surface/Pipe (code -11):** 6.23 x 6.23 x 3.23 in. (158 x 158 x 82 mm); see page 8 for dimensions of pipe mounting bracket.  
**Conduit openings:** Accepts PG13.5 or 1/2 in. conduit fittings  
**Display:** Two line, 16-character, back-lit display. Character height: 4.8 mm. Display can be customized to meet individual requirements.  
**Ambient temperature and humidity:** 0 to 50°C, (32 to 122°F) RH 5 to 95% (non-condensing)  
 Note: The analyzer is operable from -20 to 60°C (-4 to 140°F) with some degradation in display performance.

**Power:**  
 115/230 Vac ±15%, 50/60 Hz ±6%, 8.0W  
 Installation Category II  
 Equipment protected throughout by double insulation.  
**Hazardous Location:** Applies to analyzer only, not to system

**RFI/EMI:** EN-61326   
**LVD:** EN-61010-1

**Outputs:** Two 4-20 mA or 0-20 mA isolated outputs. Continuously adjustable. Linear or logarithmic. Maximum load 600 ohms. Output dampening with time constant of 5 sec is user-selectable.

**Alarms:** Three alarm relays for process measurement(s) or temperature. Alarm 3 can be configured as a fault alarm, instead of a process alarm. Each relay can be configured independently. Alarm logic (high or low activation) and deadband are user-programmable.

**Relays:** Form C, single pole double throw, epoxy sealed



	Resistive	Inductive
28 Vdc	5.0 A	3.0 A
115 Vac	5.0 A	3.0 A
230 Vac	5.0 A	1.5 A

**Terminal Connections Rating:** 26-14 AWG wire size  
**Weight/Shipping weight** (rounded up to nearest lb or nearest 0.5 kg): 3 lb (1.5 kg)/4 lb (2.0 kg)

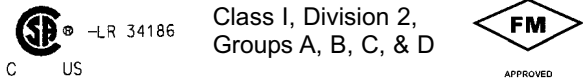

**POLLUTION DEGREE 4:** Extended Environment  
 Outdoor use where conductive contamination such as rain, snow, or dust may be present. (Hazardous Location only)

## 1.4 SPECIFICATIONS — MODEL 499ACL-02 SENSOR

**Wetted Parts:** Gold, Noryl<sup>1</sup> (PPO), Viton<sup>2</sup>, EPDM, Silicone

**Dimensions:** 1.0 x 5.6 in. (25.4 x 143 mm)

**Cable:** 25 ft. (7.6m) standard

**Pressure Rating:** 0 to 65 psig (101 to 549 kPa)

**Temperature Rating:** 32 to 122°F (0 to 50°C)

**Electrolyte Capacity:** Approximately 25 mL

**Electrolyte Life:** Approximately 4 months

**Weight/Shipping Weight:** 1 lb/3 lb (0.5 kg/1.5 kg)

<sup>1</sup> Noryl is a registered trademark of General Electric.

<sup>2</sup> Viton is a registered trademark of DuPont Performance Elastomers.

## 1.5 PERFORMANCE SPECIFICATIONS — COMPLETE SYSTEM

**Linear Range:** 0 to 20 ppm (mg/L) as Cl<sub>2</sub> (for higher ranges, consult factory)

**Linearity (per ISO 15839):** 0-10 ppm: 2%; 0-20 ppm: 3%

**Response Time:** Following a step change in concentration, the reading reaches 90% of final value within 7 minutes at 25°C.

**Drift:** At about 1.5 ppm in clean water and constant temperature, drift is typically less 0.05 ppm over two weeks.

**Detection Limit (per ISO 15839):** 0.02 ppm (mg/L) in clean water at room temperature

## 1.6 ORDERING INFORMATION AND ACCESSORIES

**Model TCL Reagent-Based Chlorine System.** The TCL is used for the continuous determination of total chlorine in water. The TCL consists of a sample conditioning system, a reagent carboy, a sensor, and an analyzer. **Reagents must be ordered separately. Regent kits for 0-5 ppm and 0-10 ppm chlorine are available. For higher ranges, consult the factory. See ACCESSORIES - Sample Conditioning System.**

MODEL TCL	REAGENT-BASED CHLORINE SYSTEM
CODE	POWER (required selection)
11	115 V 50/60 Hz
12	230 V 50/60 Hz

CODE	ANALYZER (optional selection)
250	1055-01-10-24 analyzer, panel mount
251	1055-01-11-24 analyzer, pipe/wall mount
260	54eA-01 analyzer
261	54eA-01-09 analyzer with HART communications
262	54eA-01-20 controller with PID and TPC control
263	54eA-01-09-20 controller with PID and TPC control and HART communications

CODE	SENSOR (optional selection)
30	499ACL-02-54 sensor with standard cable
31	499ACL-02-54-60 sensor with optimum EMI/RFI cable
32	499ACL-02-54-VP sensor with Variopol 6.0 fitting (interconnecting cable must be ordered separately)

## ACCESSORIES — SAMPLE CONDITIONING SYSTEM

PN	Description	Weight*	Ship Weight**
24134-00	Air pump, 115 Vac, 50/60 Hz	1 lb (0.5 kg)	1 lb (0.5 kg)
24134-01	Air pump, 230 Vac, 50/60 Hz	1 lb (0.5 kg)	1 lb (0.5 kg)
9160578	Air pump repair kit	1 lb (0.5 kg)	1 lb (0.5 kg)
9322052	Check valve for air injection line	1 lb (0.5 kg)	1 lb (0.5 kg)
24153-00	Carboy for reagent, 5 gal/19 L, includes cap	4 lb (1.5 kg)	5 lb (2.0 kg)
9100204	Fuse, 0.25 A, 250 V, 3AG, slow blow for option -11 (115 Vac)	1 lb (0.5 kg)	1 lb (0.5 kg)
9100132	Fuse, 0.125 A, 250 V, 3AG, slow blow for option -12 (230 Vac)	1 lb (0.5 kg)	1 lb (0.5 kg)
9380094	Reagent pump, 115 Vac, 50/60 Hz	1 lb (0.5 kg)	2 lb (1 kg)
9380095	Reagent pump, 230 Vac, 50/60 Hz	1 lb (0.5 kg)	2 lb (1 kg)
9380091	Reagent pump replacement tubing	1 lb (0.5 kg)	2 lb (1 kg)
24151-00	Reagent tubing replacement kit	1 lb (0.5 kg)	2 lb (1 kg)
24135-00	Reagent uptake tubing, 6 ft (1.8 m), includes weight	1 lb (0.5 kg)	2 lb (1 kg)
9380090	Sample pump, 115 Vac, 50/60 Hz	1 lb (0.5 kg)	2 lb (1 kg)
9380093	Sample pump, 230 Vac, 50/60 Hz	1 lb (0.5 kg)	2 lb (1 kg)
9380092	Sample pump replacement tubing	1 lb (0.5 kg)	2 lb (1 kg)
24152-00	Sample tubing replacement kit	1 lb (0.5 kg)	2 lb (1 kg)

PN	Description	Weight*	Ship Weight**
24165-00	Acetic acid, 2 x 2.5 gal (9.5 L) bottles/case, with 25 g potassium iodide (0-5 ppm total chlorine)	45 lb (20.5 kg)	48 lb (22.0 kg)
24165-01	Acetic acid, 2 x 2.5 gal (9.5 L) bottles/case, with 50 g potassium iodide (0-10 ppm total chlorine)	45 lb (20.5 kg)	48 lb (22.0 kg)
24164-00	Potassium iodide, 25 g, sufficient for 5 gallons (19 L) of vinegar (0-5 ppm total chlorine)	1 lb (0.5 kg)	1 lb (0.5 kg)
24164-01	Potassium iodide, 50 g, sufficient for 5 gallons (19 L) of vinegar (0-10 ppm total chlorine)	1 lb (0.5 kg)	1 lb (0.5 kg)

\*Weights are rounded up to the nearest whole pound or 0.5 kg.

## ACCESSORIES — 1055-24 Analyzer

PN	DESCRIPTION	WEIGHT*	SHIP WEIGHT*
9240048-00	Tag, stainless steel, specify marking	1 lb (0.5 kg)	1 lb (0.5 kg)
23820-00	Pipe mounting kit	2 lb (1.0 kg)	3 lb (1.5 kg)
23554-00	Gland fitting PG 13.5, 5 per package	1 lb (0.5 kg)	1 lb (0.5 kg)

## ACCESSORIES — 54eA Analyzer

PN	DESCRIPTION	WEIGHT*	SHIP WEIGHT*
2002577	Wall and two inch pipe mounting kit	2 lb (1.0 kg)	3 lb (1.5 kg)
23545-00	Panel mounting kit	2 lb (1.0 kg)	3 lb (1.5 kg)
23554-00	Cable glands, kit (Qty 5 of PG 13.5)	1 lb (0.5 kg)	1 lb (0.5 kg)
9240048-00	Stainless steel tag (specify marking)	1 lb (0.5 kg)	1 lb (0.5 kg)

## ACCESSORIES — Sensor

PN	DESCRIPTION	WEIGHT*	SHIP WEIGHT*
23501-02	Total Chlorine Membrane, includes one membrane assembly and one O-ring	1 lb (0.5 kg)	1 lb (0.5 kg)
23502-02	Total Chlorine Membrane Kit, includes 3 membrane assemblies and three O-rings	1 lb (0.5 kg)	1 lb (0.5 kg)
R434-6OZ	Total Chlorine Sensor Fill Solution, includes electrolyte and KI crystals to be mixed before use, sufficient for 3 recharges	1 lb (0.5 kg)	2 lb (1.0 kg)

## FOR FIRST TIME VARIOPOL INSTALLATIONS

PN	DESCRIPTION	WEIGHT*	SHIP WEIGHT*
23747-02	VP 6.0 interconnecting cable, 10 ft (3 m)	1 lb (0.5 kg)	2 lb (1.0 kg)
23747-03	VP 6.0 interconnecting cable, 50 ft (15 m)	5 lb (2.5 kg)	6 lb (3.0 kg)
23747-04	VP 6.0 interconnecting cable, 4 ft (1.2 m)	1 lb (0.5 kg)	1 lb (0.5 kg)

\*Weights are rounded up to the nearest whole pound or 0.5 kg.

## SECTION 2. PRINCIPLES OF OPERATION

Total chlorine by definition is the iodine produced in a sample when it is treated with potassium iodide at a pH between 3.5 and 4.5. Typically, acetic acid (or vinegar) is used to adjust the pH.

The total chlorine analyzer consists of a sample conditioning system, which injects the reagent into the sample, and a sensor and analyzer, which measure the amount of iodine produced. Figure 2-1 shows the sample conditioning system. The sample enters the sample conditioning enclosure and flows to an overflow sampler from which the sample pump takes suction. Excess sample drains to waste. At the same time, the reagent pump draws reagent, a solution of potassium iodide in vinegar, from the reagent carboy and injects it into the suction side of the sample pump. The sample and reagent mix as they pass through the pump, and total chlorine in the sample is converted to the chemically equivalent amount of iodine. The flow rates are 11 mL/min for the sample and 0.2 mL/min for the reagent.

The treated sample next enters the flow cell. Bubbles injected into the flow cell produce turbulence, which improves the stability of the reading. A membrane-covered amperometric sensor in the flow cell measures the concentration of iodine. The analyzer receives the raw signal from the sensor and displays the concentration of total chlorine. Display units are ppm (mg/L) chlorine as  $\text{Cl}_2$ . The treated sample leaves the flow cell and drains to waste along with the excess sample.

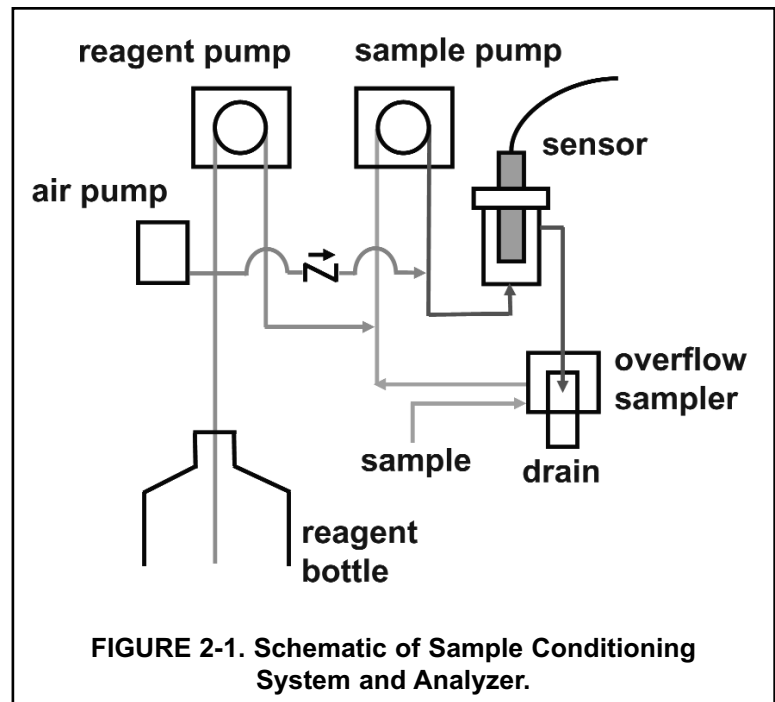

## SECTION 3. INSTALLATION

### 3.1 UNPACKING AND INSPECTION

Inspect the shipping containers. If there is damage, contact the shipper immediately for instructions. Save the boxes. If there is no apparent damage, unpack the containers. Be sure all items shown on the packing list are present. If items are missing, notify Rosemount Analytical immediately.

### 3.2 INSTALLATION.

#### 3.2.1 General Information

1. Although the analyzer and sample conditioning system are suitable for outdoor use, do not install them in direct sunlight or in areas of extreme temperature.

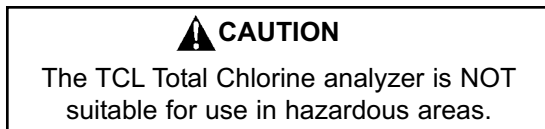

2. Install the analyzer and sample conditioning system in an area where vibration and electromagnetic and radio frequency interference are minimized or absent.
3. Keep the analyzer and sensor wiring at least one foot from high voltage conductors. Be sure there is easy access to the analyzer and sample conditioning system.
4. The analyzer is suitable for panel, pipe or wall mounting. The sample conditioning enclosure must be mounted on a wall. Provide adequate room beneath the enclosure for the 5-gallon reagent carboy.
5. Be sure that the distance between the analyzer and sample conditioning cabinet does not exceed the length of the sensor cable.

#### 3.2.2 Install the Analyzer

1. The analyzer enclosure has two conduit openings and three knockouts. Refer to Section 4.1 for removal of the conduit knockouts.
2. Refer to the appropriate figure for installation details.

Type of Mounting	Figure
Panel	3-1
Pipe	3-2
Wall or surface	3-3

3. See Section 4.2 for wiring instructions.

Panel Mounting.

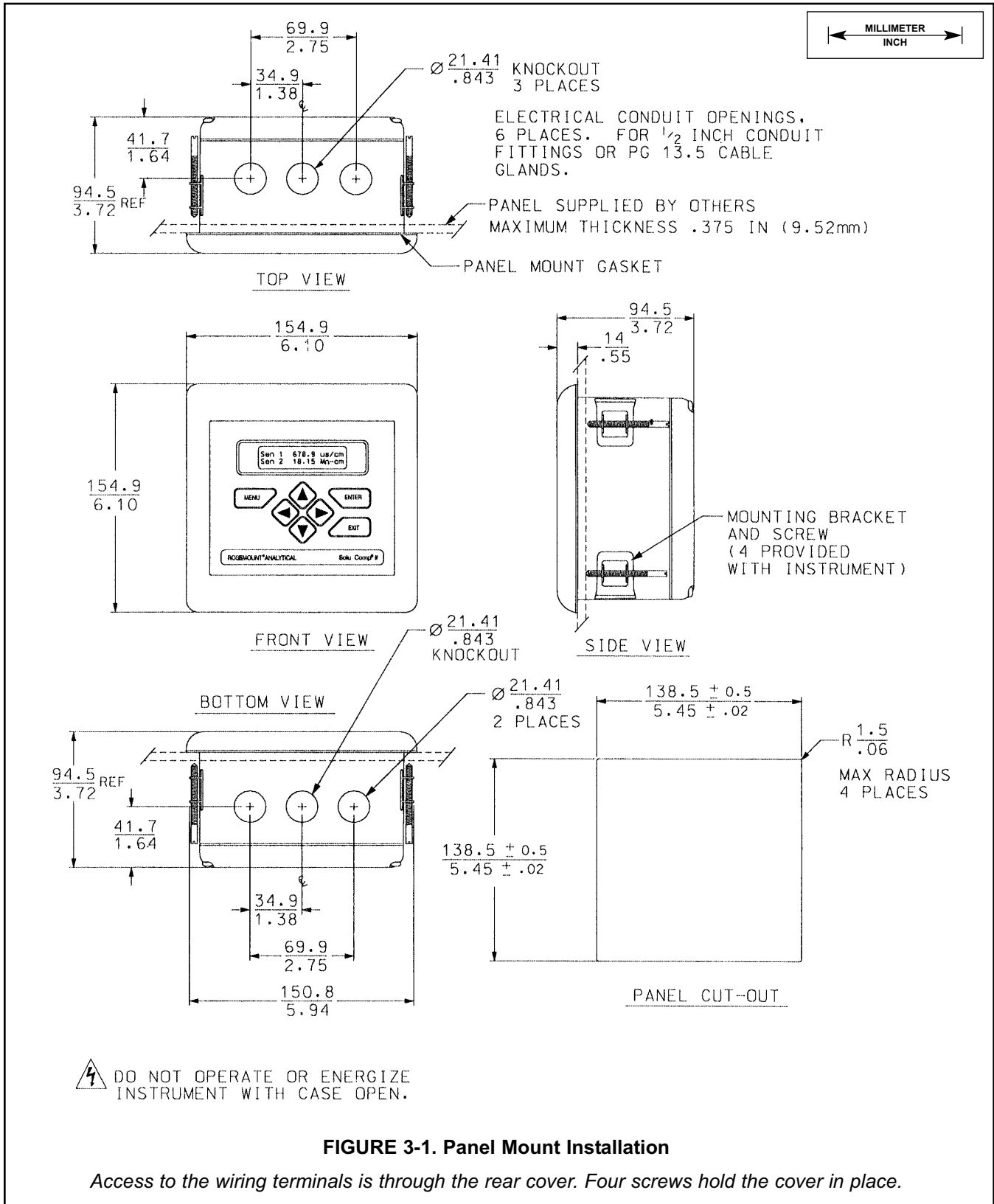

Pipe Mounting.

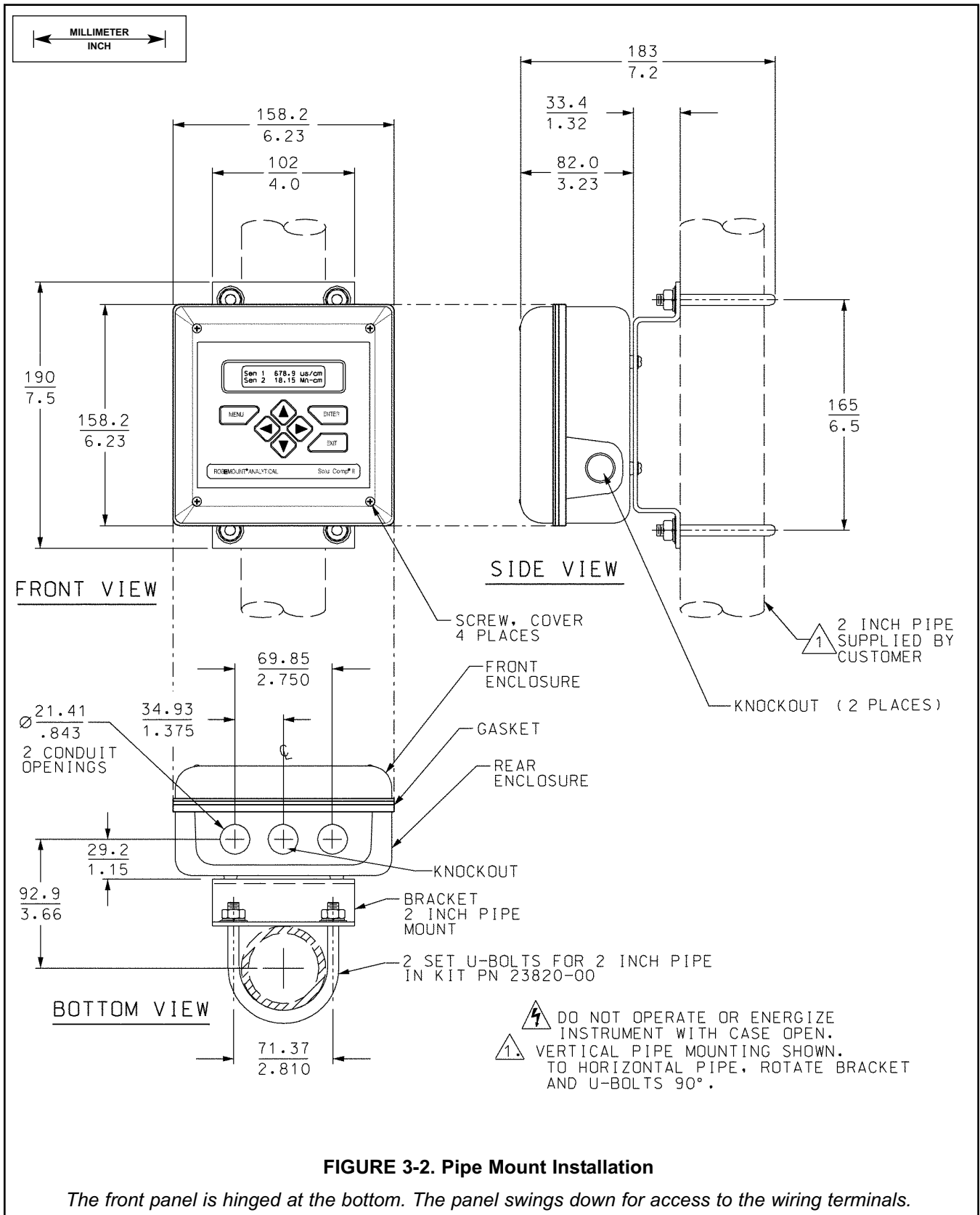

**FIGURE 3-2. Pipe Mount Installation**

*The front panel is hinged at the bottom. The panel swings down for access to the wiring terminals.*

Surface Mounting.

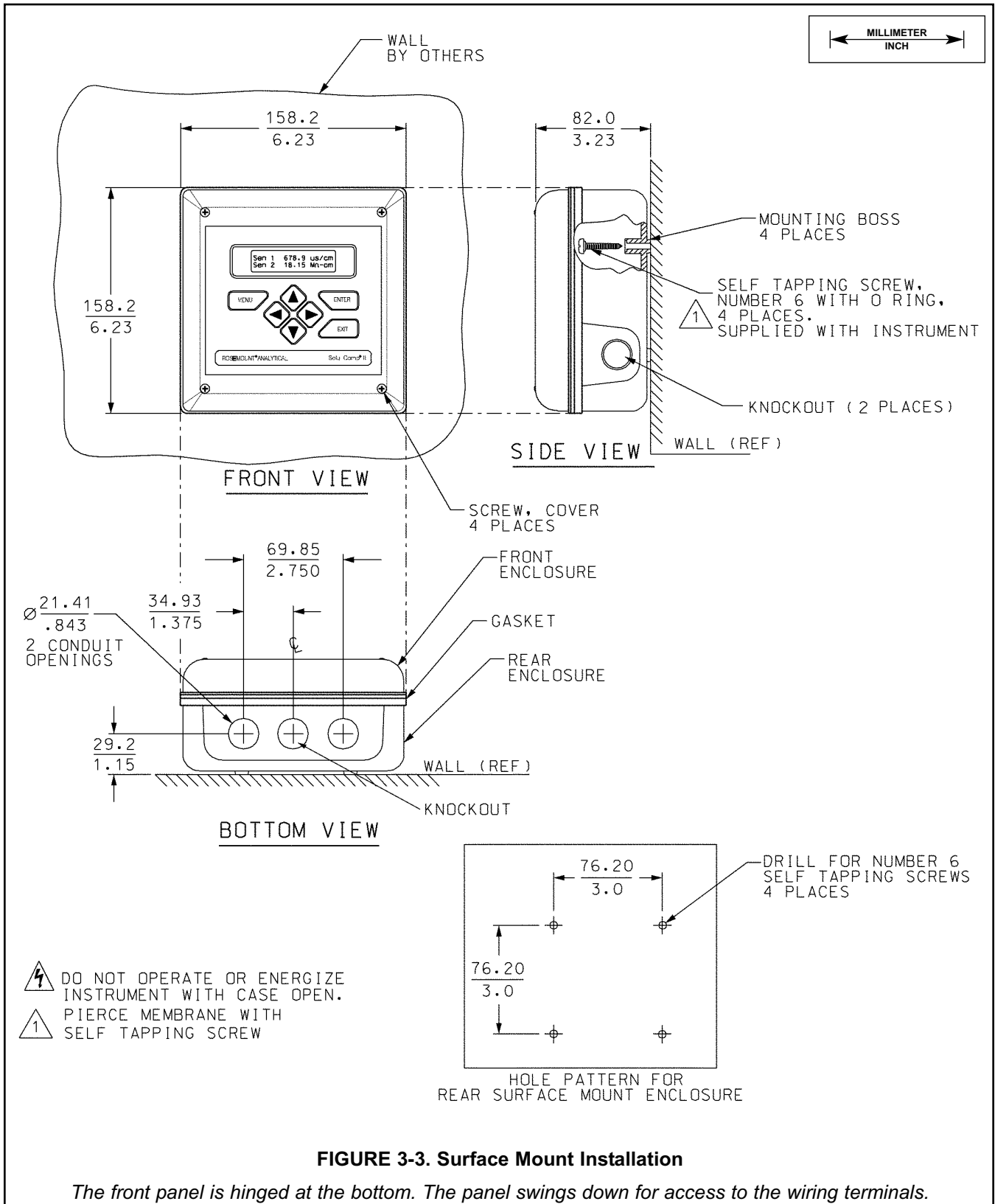

**FIGURE 3-3. Surface Mount Installation**

*The front panel is hinged at the bottom. The panel swings down for access to the wiring terminals.*

### 3.2.3 Install the Sample Conditioning Enclosure

1. Refer to Figures 3-4, 3-5, and 3-6 for installation details.
2. Connect the sample line to the sample conditioning system. Use ¼-inch OD hard plastic or stainless steel tubing. If dechlorinated water is being measured, provide a way of substituting a chlorinated water sample for the dechlorinated sample. Chlorinated water is needed to calibrate the sensor and to check its response.
3. If a grab sample tap is not already available, install one in the process piping. Choose a point as close as possible to the sample line supplying the TCL. Be sure that opening the sample valve does not appreciably alter the flow of sample to the instrument.
4. Connect the drain to a length of ¾-inch ID flexible plastic tubing. The sample **must** drain to open atmosphere.
5. Find the reagent tubing and fitting in the plastic bag taped to the inside of the enclosure door. Screw the reagent fitting onto the bulkhead fitting at the bottom left of the enclosure. Pass the reagent tubing through the hole in the carboy cap. Be sure the plastic weight will be inside the carboy when the cap is in place. Attach the reagent tubing to the barbed connector. See Figure 3-6.
6. Place the blue plastic carboy beneath the enclosure. Screw the cap and tubing on to the carboy. To prepare reagent, see Section 5.2.

### 3.2.4 Install the Sensor

1. From inside the sample conditioning enclosure, thread the sensor cable through the gland on the upper left side. Leave about one foot of cable inside the enclosure.
2. Wire the sensor to the analyzer. Refer to Section 4.2.3.
3. Remove the nut and adapter from the flow cell. Slip the nut over the end of the sensor. Thread the adapter onto the sensor. Hand tighten only. Remove the protective cap from the end of the sensor.
4. Insert the sensor in the flow cell. Hand tighten the nut.

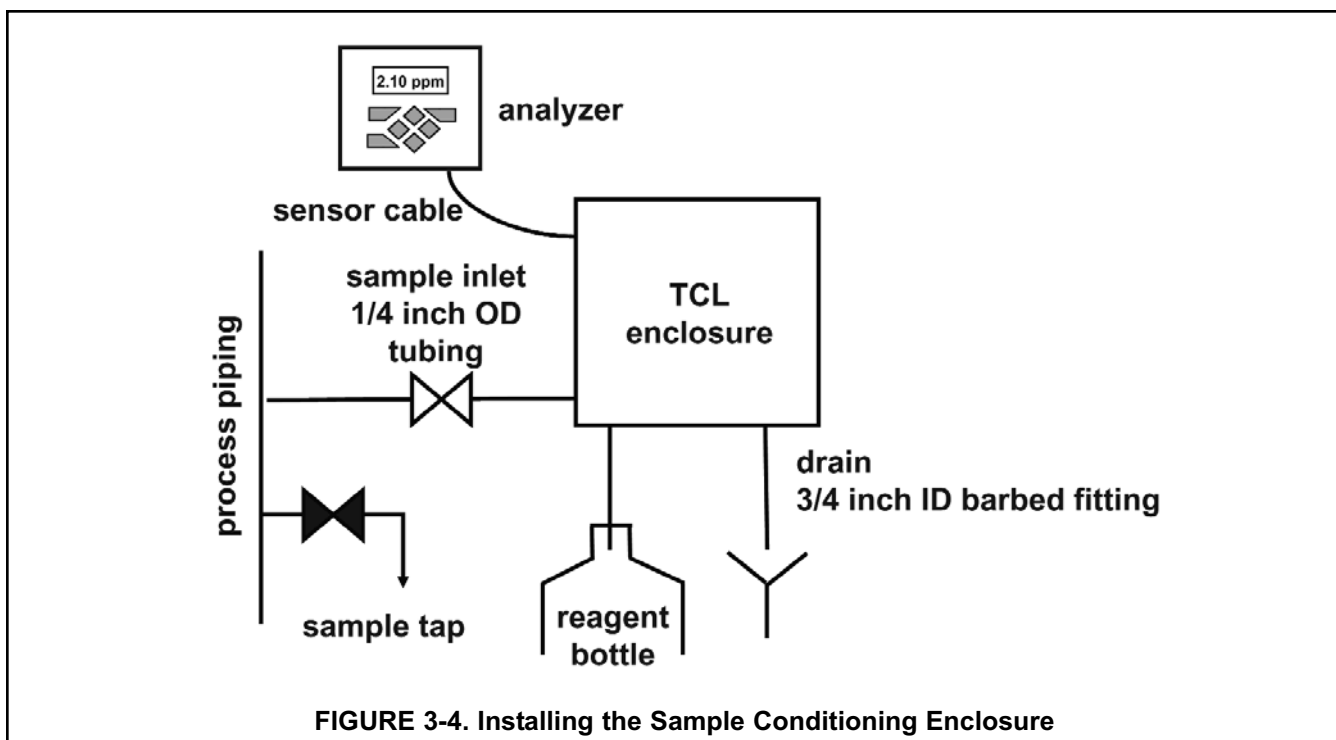

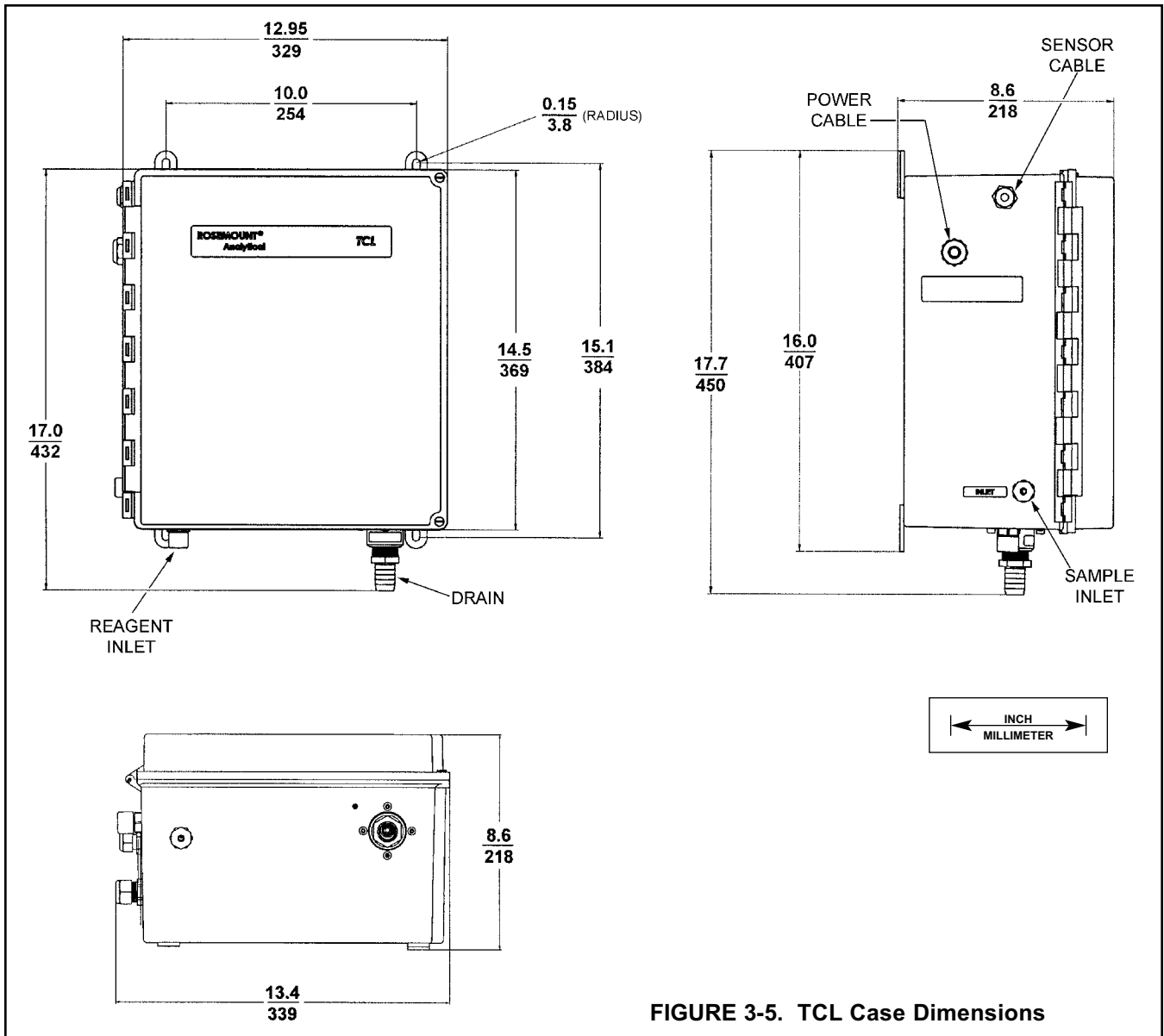

FIGURE 3-5. TCL Case Dimensions

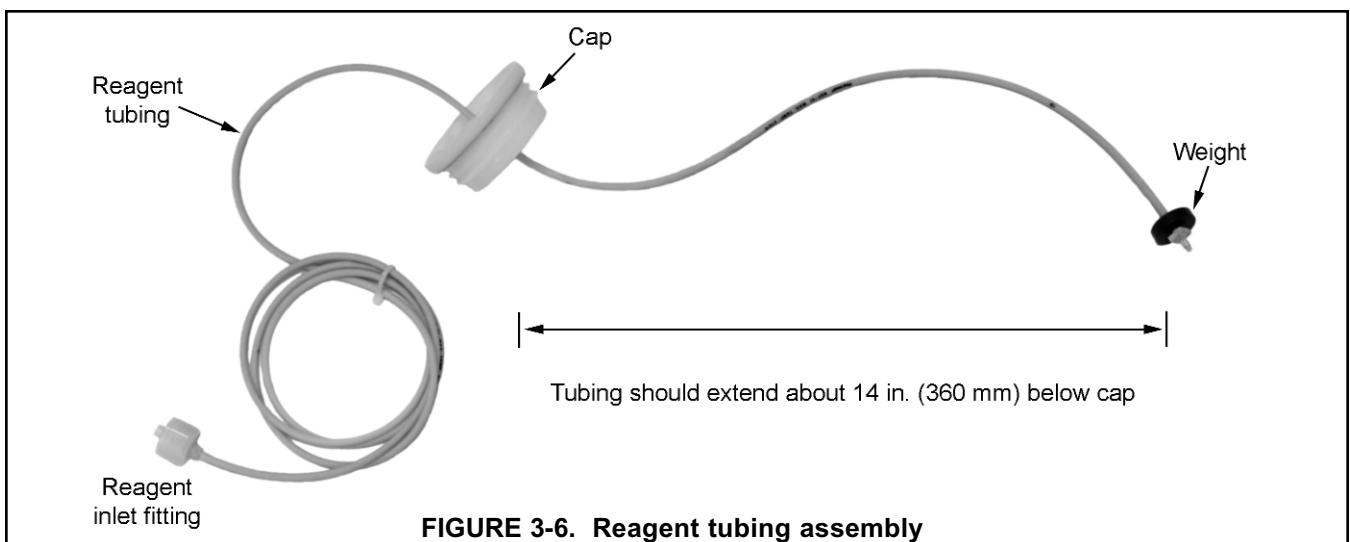

FIGURE 3-6. Reagent tubing assembly

## SECTION 4. WIRING

### 4.1 PREPARE ANALYZER CONDUIT OPENINGS

The analyzer enclosure has two conduit openings and three knockouts.

Conduit openings accept 1/2-inch conduit fittings or PG 13.5 cable glands. To keep the case watertight, block unused openings with NEMA 4X or IP65 conduit plugs.

#### NOTE

Use watertight fittings and hubs that comply with the requirements of UL514B. Connect the conduit hub to the conduit before attaching the fitting to the analyzer (UL508-26.16).

Figure 4-1 shows how to remove the knockouts. The knockout grooves are on the outside of the case. Place the screwdriver blade on the inside of the case and align it approximately along the groove. Rap the screwdriver sharply with a hammer until the groove cracks. Move the screwdriver to an uncracked portion of the groove and continue the process until the knockout falls out. Use a small knife blade to remove the flash from the inside of the hole.

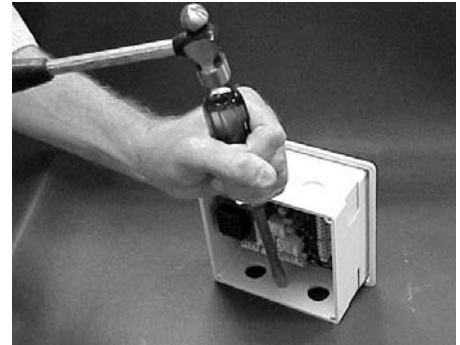



FIGURE 4-1. Removing the Knockouts

### 4.2 PROVIDE POWER TO THE SAMPLE CONDITIONING SYSTEM



**WARNING: RISK OF ELECTRICAL SHOCK**  
AC connections and grounding must be in compliance with UL 508 or local electrical code. DO NOT apply power to the analyzer until all electrical connections are verified and secure.

#### NOTE

Provide a switch or breaker to disconnect the sample conditioning cabinet from the main power supply. Install the switch or breaker near the unit and identify it as the disconnecting device for the sample conditioning system.

1. Be sure the pump switches on the wiring access panel are in the off position.
2. Remove the four screws securing the wiring access panel. Pull the panel out of the way to reveal the power terminal strip.
3. Insert the power cable through the strain relief connection labeled power (see Figure 3-5). Wire the power cable to the terminal strip as shown in Figure 4-2. Do not apply 230 Vac power to a 115 Vac TCL (Model option -11). Doing so will damage the instrument.
4. **Leave the pump power switches off until ready to start up the unit.** See Section 5.

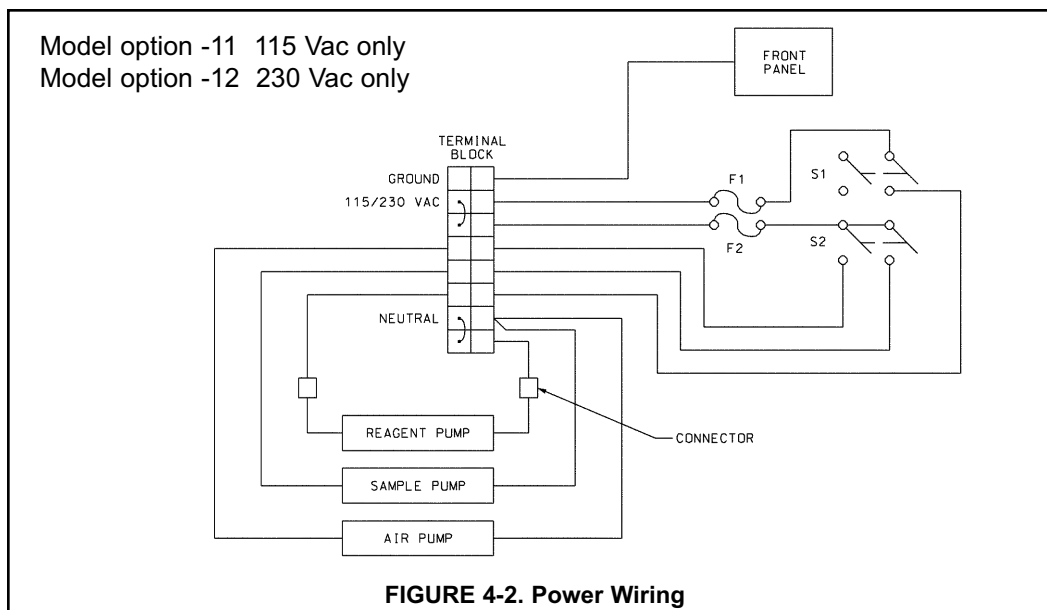

### 4.3 MAKE POWER, ALARM, OUTPUT, AND SENSOR CONNECTIONS IN THE ANALYZER



**WARNING: RISK OF ELECTRICAL SHOCK**  
AC connections and grounding must be in compliance with UL 508 or local electrical code. DO NOT apply power to the analyzer until all electrical connections are verified and secure.

The Solu Comp II is available in two mounting configurations. The positions of the power, alarm, output, and sensor terminals are different in each. Figure 4-3 shows wiring for the panel mount version. Figure 4-4 shows wiring for the wall/pipe mount version.

For best EMI/RFI protection use shielded output signal cable enclosed in an earth-grounded metal conduit. Connect the shield to earth ground at terminal 4 on TB1.

Do not run sensor and power or relay wiring in the same conduit or close together in a cable tray.

AC wiring should be 14 gauge or greater.

**NOTE**

Provide a switch or breaker to disconnect the analyzer from the main power supply. Install the switch or breaker near the analyzer and label it as the disconnecting device for the analyzer.

**Do not bring AC power and relay wiring in through the top conduit opening (panel mount analyzer only).**

**Keep AC power and relay wiring separated from other wiring in the analyzer.**

**Do not allow wiring to press on the transformer and power supply board.**

**To reduce the likelihood of stress on wiring connections, do not remove the hinged front cover of the wall/pipe mount enclosure while making connections. Be sure there is sufficient cable slack in the enclosure to avoid stress on conductors.**

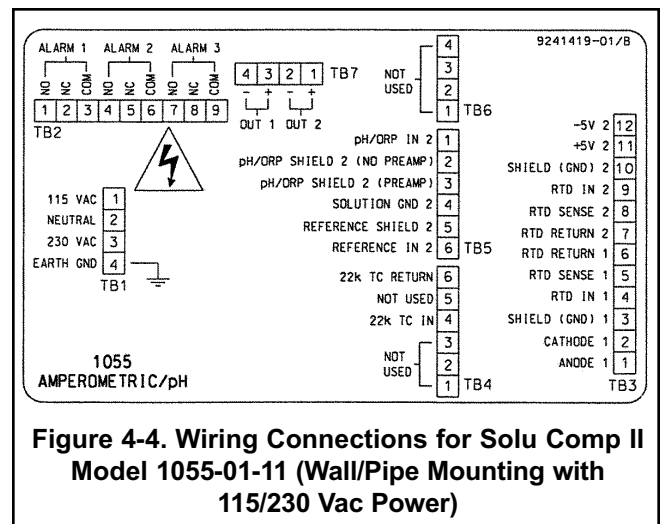
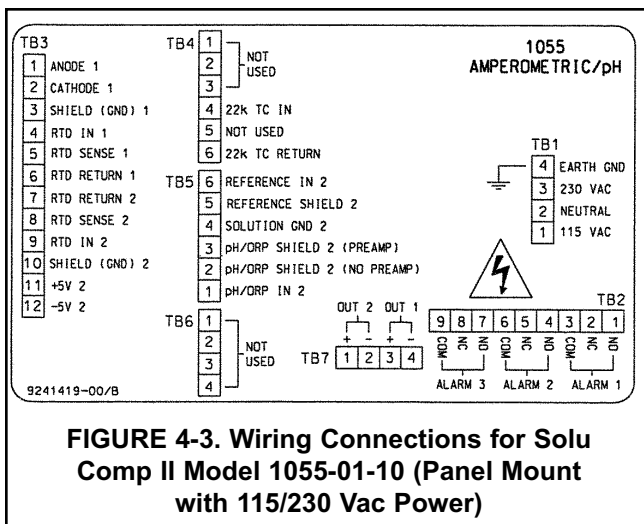

Refer to Figures 4-5 and 4-6 for sensor wiring. Use the pigtail wire and wire nuts provided with the sensor when more than one wire must be attached to a single terminal.

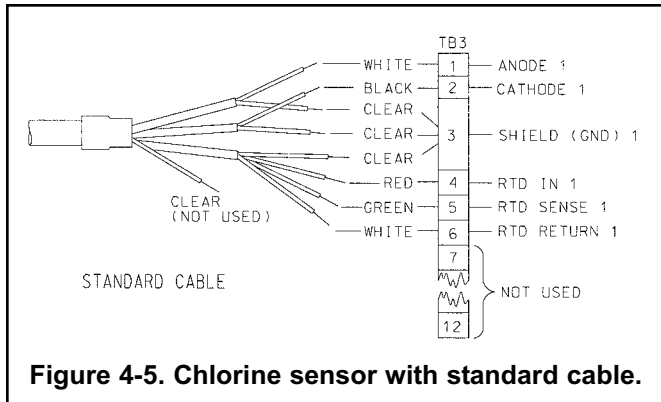

Figure 4-5. Chlorine sensor with standard cable.

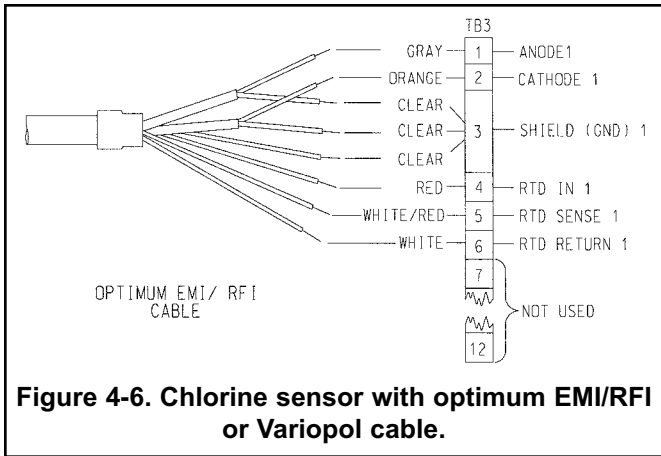

Figure 4-6. Chlorine sensor with optimum EMI/RFI or Variopol cable.

#### 4.4 APPLY POWER TO THE ANALYZER AND COMPLETE QUICK START

1. Once all wiring connections are secure, apply power to the analyzer.
2. When the analyzer is powered up for the first time, **Quick Start** screens appear. Using **Quick Start** is easy.
  - a. A blinking field shows the position of the cursor.
  - b. Use the ◀ or ▶ key to move the cursor left or right. Use the ▲ or ▼ key to move the cursor up or down or to increase or decrease the value of a digit. Use the ▲ or ▼ key to move the decimal point.
  - c. Press ENTER to store a setting. Press EXIT to leave without storing changes. Pressing EXIT also returns the display to the previous screen.

```

English      Fran ais
Espa ol      >>

S1 Chlorine Type
free        total >>

Temperature in?
C          F
    
```

3. Choose the desired language. Choose >> to show more choices.
4. Choose **total** for chlorine type.
5. Choose temperature units.
6. The main display appears. The outputs and alarms are assigned to default values.
7. To change outputs, alarms, and temperature-related settings, go to the main menu and choose **Program**. Follow the prompts. For a guide to the Program menu, see the menu tree on the following page.
8. To return the analyzer to the default settings, choose **Reset Analyzer** in the Program menu.

## SECTION 5. START-UP

### NOTE

Complete Section 4 before starting this section.

### 5.1 PREPARE THE REAGENT



### WARNING

The reagent contains potassium iodide dissolved in distilled vinegar or 5% acetic acid. Avoid contact with skin and eyes. Wash thoroughly after using.

1. **DO NOT PREPARE THE SOLUTION UNTIL READY TO USE.**
2. Position the blue plastic carboy under the sample conditioning cabinet. Unscrew the cap and reagent tube assembly.
3. Add the potassium iodide reagent to the carboy. See the table.

Expected range, ppm as Cl <sub>2</sub>	Amount of KI needed per 5 gal (19 L) of vinegar	Part number
0 – 5 ppm	25 grams	24164-00
0 – 10 ppm	50 grams	24164-01
0 – 20 ppm	2 x 50 grams	24164-01

4. Add five gallons (19 L) of distilled white vinegar one gallon (4 L) at a time. Swirl the carboy after each addition
5. Screw the cap on the carboy. Be sure the reagent uptake tube extends to the bottom of the carboy.
6. Connect the reagent tube to the small fitting on the bottom left hand side of the enclosure.

### NOTE

The shelf life of the potassium iodide vinegar solution is at least two months if stored in the blue carboy. Do not store the reagent in a container other than the blue carboy. The reagent is sensitive to sunlight, which the blue carboy effectively blocks.

### 5.2 ZERO THE SENSOR

1. Place the sensor in a beaker of deionized water or simply place the sensor in air.
2. Let the sensor operate until the sensor current is stable, then zero the sensor. See Section 8.3.2 for detailed instructions.

### 5.3 START SAMPLE FLOW

Adjust the sample flow until a slow stream of liquid is running down the inside tube of the sampling cup.



### 5.4 BEGIN OPERATION AND CALIBRATE THE SENSOR

1. Turn on the reagent and sample pump switches. Observe that liquid begins to fill the flow cell. The sample flow is about 11 mL/min, so the flow cell will fill rather slowly. Also observe that the air pump is operating. The pump will produce very vigorous bubbling in the flow cell.
2. Once the flow of reagent starts, it takes about two minutes for the reagent to reach the flow cell. If the concentration of total chlorine in the sample is greater than about 0.5 ppm, the treated sample in the flow cell will be pale yellow. Sample containing more chlorine will be dark yellow.
3. Monitor the sensor current. Once the reading is stable, calibrate the unit. See Section 8.3.3 for detailed instructions. It may take thirty minutes or longer for the reading to stabilize when the sensor is first put in service.

## SECTION 6. DISPLAY AND OPERATION

### 6.1. DISPLAY

The Solu Comp II analyzer has a two-line display. The display can be customized to meet user requirements. Figure 6-1 shows the two displays available.

The Solu Comp II has information screens that supplement the data in the main display. Press  or  to view the information screens. **The last information screen is the software version.**

During calibration and programming, key presses cause different displays to appear. The displays are self-explanatory and guide the user step-by-step through the procedure.

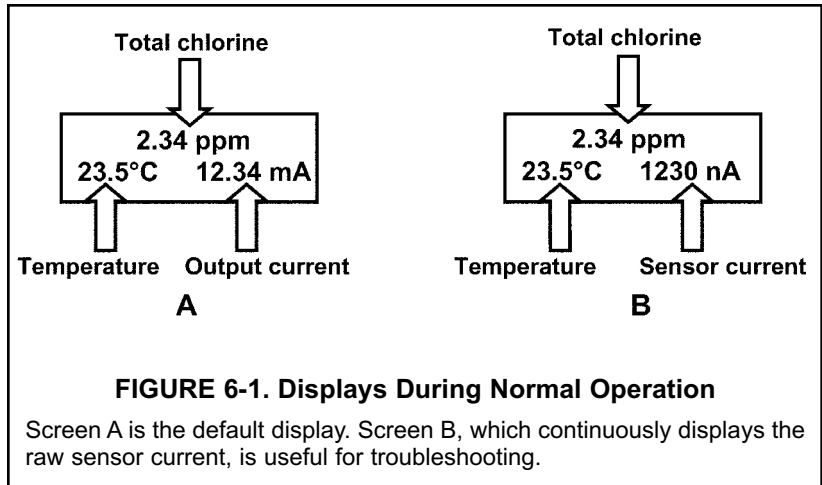

### 6.2 KEYPAD

Figure 6-2 shows the Solu Comp II keypad.

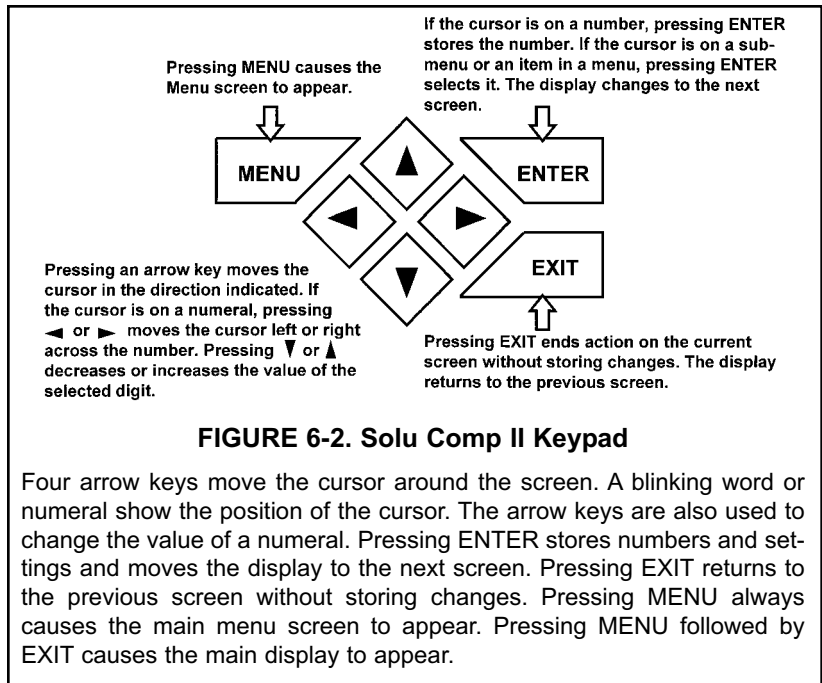

### 6.3 PROGRAMMING AND CALIBRATING THE SOLU COMP II - TUTORIAL

Setting up and calibrating the Solu Comp II is easy. The following tutorial describes how to move around in the programming menus. For practice, the tutorial also describes how to assign chlorine values to the 4 and 20 mA outputs for sensor 1.

```

Calibrate          Hold
Program           Display
  
```

```

Calibrate          Hold
Program           Display
  
```

```

Outputs           Alarms
Measurement       >>
  
```

```

Output Range
Output Configure
  
```

```

Output Range?
Output1          Output2
  
```

```

Out1 S1 Range?
4mA              00.00PPM
  
```

```

Out1 S1 Range?
20mA             20.00PPM
  
```

```

Output Range?
Output1          Output2
  
```

1. If the MENU screen (shown at the left) is not already showing, press MENU. **Calibrate** is blinking, which means the cursor is on **Calibrate**.
2. To assign chlorine or pH values to current outputs, the **Program** sub-menu must be open. Press **▼**. The cursor moves to **Program** (**Program** blinking). Press ENTER. Pressing ENTER opens the **Program** sub-menu.
3. The **Program** sub-menu permits the user to set outputs, alarms, automatic or manual temperature compensation, and a security code. When the sub-menu opens, **Outputs** is blinking, which means the cursor is on Outputs. Press **▼** or **▶** (or any arrow key) to move the cursor around the display. Move the cursor to **>>** and press ENTER to cause a second screen with more program items to appear. There are three screens in the **Program** menu. Pressing **>>** and ENTER in the third screen causes the display to return to the first screen (**Outputs**, **Alarms**, **Measurement**).
4. For practice, assign values to the 4 and 20 mA outputs for sensor 1. Move the cursor to **Outputs** and press ENTER.
5. The screen shown at left appears. The cursor is on **Output Range** (blinking). Output range is used to assign values to the low and high current outputs. Press ENTER.
6. The screen shown at left appears. The Solu Comp II has two outputs, output 1 and output 2. Move the cursor to the desired output and press ENTER. For purposes of the example, choose **Output 1**.
7. The screen shown at left appears. **Out1 S1** in the top line means output 1 (**Out1**) is assigned to sensor 1 (**S1**). Either output can be assigned to either sensor (sensor and output assignments are made under the **Output Configure** menu shown in step 5). Use the **Out1 S1 Range?** screen to assign a chlorine concentration to the **4 mA** output.
  - a. Use the arrow keys to change the concentration to the desired value. Press **◀** or **▶** to move the cursor from digit to digit. Press **▲** or **▼** to increase or decrease the value of the digit. Holding **▲** or **▼** down causes the numeral to continuously scroll up or down.
  - b. To move the decimal point, press **◀** or **▶** until the cursor is on the decimal point. Press **▲** to move the decimal point to the right. Press **▼** to move the decimal point to the left.
  - c. Press ENTER to store the setting.
8. The screen shown at left appears. Use this screen to assign a full scale chlorine concentration to the **20 mA** output. Use the arrow keys to change the chlorine to the desired value. Press ENTER to store the setting.
9. The screen shown at left appears. To assign values to the low and high currents for output 2, select **Output 2** and follow the prompts.
10. To return to the main menu, press MENU. To return to the main display press MENU then EXIT, or press EXIT repeatedly until the main display appears. To return to the previous display press EXIT.

#### NOTE

To store values or settings, press ENTER before pressing EXIT.

## 6.4 SECURITY

### 6.4.1 How the Security Code Works

Use the security code to prevent accidental or unwanted changes to program settings, displays, and calibration.

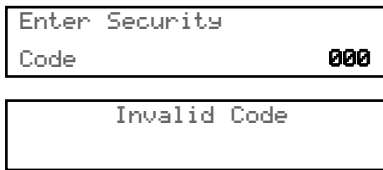

1. If a security code has been programmed, pressing MENU causes the security screen to appear.
2. Enter the three-digit security code.
3. If the entry is correct, the main menu screen appears. If the entry is incorrect, the **Invalid Code** screen appears. The **Enter Security Code** screen reappears after 2 seconds.

### 6.4.2 Bypassing the Security Code

Enter 555. The main menu will open.

### 6.4.3 Setting a Security Code

See Section 7.7.

## 6.5 USING HOLD

### 6.5.1 Purpose

The analyzer output is always proportional to measured chlorine. To prevent unwanted alarms and improper operation of control systems or dosing pumps, place the analyzer in hold before removing the sensor for calibration and maintenance. Be sure to remove the analyzer from hold once calibration is complete. During hold, both outputs remain at the last value. **Once in hold, the analyzer remains there indefinitely.** While in hold, the screen shown to the left appears periodically.

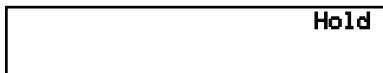

### 6.5.2 Using the Hold Function

**To choose a menu item, move the cursor to the item and press ENTER.  
To store a number or setting, press ENTER.**

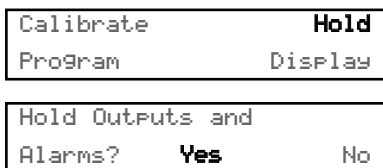

1. Press MENU. The main menu screen appears. Choose **Hold**.
2. The **Hold Outputs and Alarms ?** screen appears. Choose **Yes** to place the analyzer in hold. Choose **No** to take the analyzer out of hold.
3. The main display screen will appear.

## SECTION 7. PROGRAMMING THE ANALYZER

### 7.1 GENERAL

This section describes how to do the following:

1. configure and assign values to the current outputs
2. configure and assign setpoints to the alarm relays
3. choose the type of chlorine measurement being made
4. choose temperature units and manual or automatic temperature mode
5. set a security code
6. tell the analyzer the frequency of the ac power (needed for optimum noise rejection)
7. reset the analyzer to factory calibration and default settings
8. select a default display screen

Default settings are shown in Table 7-1. To change a default setting, refer to the section listed in the table. To reset default settings, see Section 7.10.

**TABLE 7-1. DEFAULT SETTINGS**

#### 1. OUTPUT SETTINGS

Output	Assignment	Range	Dampening	Current	Mode	Section
1	chlorine	0 - 10 ppm	off	4-20 mA	Linear	7.3
2	temperature	0-100°C	off	4-20 mA	Linear	7.3

#### 2. ALARM CONFIGURATION AND SETPOINTS

	Alarm			If Alarm 3 is a sensor alarm	Section
	1	2	3		
Assigned to	total chlorine	total chlorine	Fault	Temperature	7.4
High or low	High	Low	NA	Low	7.4
Deadband	0	0	NA	0.00	7.4
Setpoint	10 ppm	0 ppm	NA	0°C	7.4

#### 3 MISCELLANEOUS SETTINGS

		Section
Temperature units	°C	7.6
Automatic Temperature Correction	On	7.6
Sensor input filter	5 sec	7.5
Language	English	7.11
Hold	off	7.5
Security code	000 (no security code)	7.7
ac power frequency	60 Hz	7.8

### 7.2 CHANGING STARTUP SETTINGS

When the Solu Comp II is powered up for the first time, Quick Start screens appear, which enable the user to quickly configure the analyzer to measure total chlorine. Because the analyzer can be used to measure other chlorine compounds, it must be specifically configured to measure total chlorine. If incorrect settings were entered at startup, enter the correct settings now.

## 7.3 CONFIGURING AND RANGING THE OUTPUTS.

### 7.3.1 Purpose

The analyzer has two current outputs. This section describes how to configure and range the outputs. **CONFIGURE THE OUTPUTS FIRST.**

1. Configuring an output means
  - a. Selecting either a 4-20 mA or 0-20 mA output,
  - b. Turning on or turning off output current dampening,
  - c. Choosing a linear or logarithmic output.
2. Ranging the outputs means assigning values to the low (0 or 4 mA) and high (20 mA) outputs.

### 7.3.2 Definitions

1. **CURRENT OUTPUTS.** The analyzer provides either a continuous 4-20 mA or 0-20 mA output current directly proportional to total chlorine concentration.
2. **DAMPEN.** Output dampening smooths out noisy readings. It also increases the response time of the output. With output dampening the time to reach 63% of final reading following a step change is 5 sec. Output dampening does not affect the response time of the display.
3. **MODE.** The current output can be made directly proportional to the displayed value (linear mode) or directly proportional to the common logarithm of the displayed value (log mode).

### 7.3.3. Procedure: Configure Outputs.

**To choose a menu item, move the cursor to the item and press ENTER.  
To store a number or setting, press ENTER.**

Calibrate	Hold
<b>Program</b>	Display

1. Press MENU. The main menu screen appears. Choose **Program**.

<b>Outputs</b>	Alarms
Measurement	>>

2. Choose **Outputs**.

Output Range
<b>Output Configure</b>

3. Choose **Output Configure**.

Output Config?
<b>Output1</b> Output2

4. Choose **Output1** or **Output2**.

OutM is for?
<b>Measurement</b> Temp

5. Choose **Measurement** or **Temp**. **Measurement** means total chlorine.

6. Make the appropriate settings:
  - a. Choose **4-20 mA** or **0-20 mA**.
  - b. Choose **Yes** or **No** for output dampening.
  - c. Choose **Linear** or **Log** output.

7. The display returns to the **Output Config?** screen. Select the other output or press EXIT to return to the previous screen. To return to the main display, press MENU followed by EXIT.

## 7.3.4. Procedure: Assigning Values to the Low and High Current Outputs (Output Ranging)

To choose a menu item, move the cursor to the item and press ENTER.

To store a number or setting, press ENTER.

Calibrate	Hold
<b>Program</b>	Display

<b>Outputs</b>	Alarms
Measurement	>>

<b>Output Range</b>
Output Configure

1. Press MENU. The main menu screen appears. Choose **Program**.
2. Choose **Outputs**.
3. Choose **Output Range**. Choose **Output1** or **Output2**.
4. Make the appropriate settings.
  - a. Assign a value to the low current (**0 mA** or **4 mA**) output.
  - b. Assign a value to the high current (**20 mA**) output.
5. The display returns to the **Output Range** screen. Select the other output or press EXIT to return to the previous screen. To return to the main display, press MENU followed by EXIT.

## 7.4 CONFIGURING ALARMS AND ASSIGNING SETPOINTS

### 7.4.1 Purpose

This section describes how to do the following:

1. assign alarm 3 relay to the sensor or leave as a fault alarm,
2. set the alarm logic to high or low,
3. assign values to the alarm setpoints,
4. set the alarm deadbands.

**ALARM RELAYS MUST BE CONFIGURED BEFORE ASSIGNING SETPOINTS.**

### 7.4.2 Definitions

1. **ASSIGNING ALARMS.** There are three alarms (**AL1**, **AL2**, and **AL3**). Alarms 1 and 2 are always assigned to the sensor. Alarm 3 can be assigned to the sensor or used as a fault alarm. The fault alarm activates when a fault exists in a sensor or the analyzer.
2. **FAULT ALARM.** A fault condition exists when the Solu Comp II detects a problem with a sensor or with the analyzer that is likely to cause seriously erroneous readings. If Alarm 3 was programmed as a fault alarm, the alarm 3 relay will activate. The word **Fault** will appear alternately in the display with the reading.
3. **ALARM LOGIC, SETPOINTS, AND DEADBANDS.** See Figures 7-1 and 7-2.

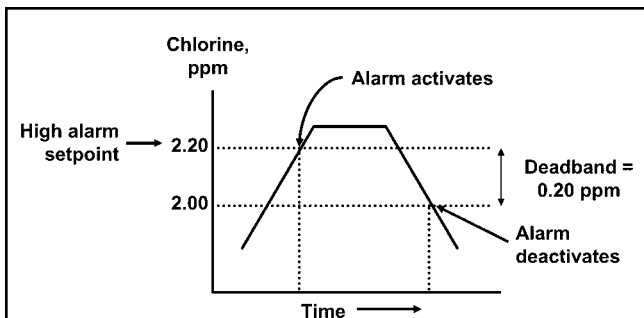

**FIGURE 7-1. High Alarm Logic**

The alarm activates when the chlorine exceeds the high setpoint. The alarm remains activated until the reading drops below the value determined by the deadband.

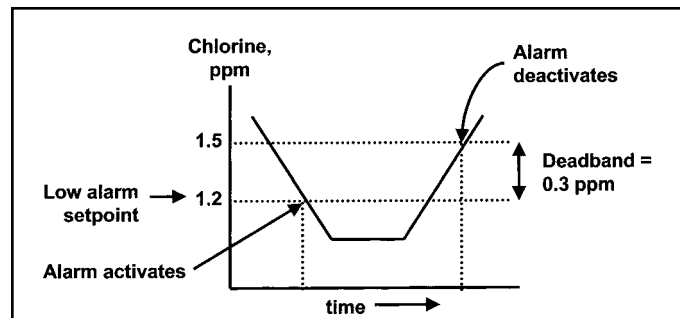

**FIGURE 7-2. Low Alarm Logic**

The alarm activates when the chlorine concentration drops below the low setpoint. The alarm remains activated until the reading increases above the value determined by the deadband.

Alarm relays are single pole-double throw (SPDT). When an alarm is activated, the coil is energized. When an alarm activates, **AL1**, **AL2**, or **AL3** (as appropriate) appears periodically in the display.

## 7.4.3 Procedure: Configuring Alarms

To choose a menu item, move the cursor to the item and press ENTER.  
To store a number or setting, press ENTER.

Calibrate	Hold
<b>Program</b>	Display

Outputs	<b>Alarms</b>
Measurement	>>

Alarm Setpoints	
<b>Alarm Configure</b>	

Alarm Config?		
<b>AL1</b>	AL2	AL3

AL1 S1 is for?	
<b>Measurement</b>	Temp

AL3 is for?	
<b>Fault</b>	Sensor1

1. Press MENU. The main menu screen appears. Choose **Program**.
2. Choose **Alarms**.
3. Choose **Alarm Configure**.
4. Choose Alarm 1 (**AL1**), Alarm 2 (**AL2**), or Alarm 3 (**AL3**).
5. For **AL1** or **AL2**
  - a. Choose **Measurement** or **Temp**.
  - b. Choose **High** or **Low**.
  - c. Set the alarm **Deadband**.
6. The display returns to the **Alarm Configure?** screen. Select another alarm or press EXIT to return to the previous screen. To return to the main display, press MENU followed by EXIT.
7. For **AL3**
  - a. Choose **Sensor1** or **Fault**.
  - b. Choose **Measurement** or **Temp**.
  - c. Choose **High** or **Low**. Set the deadband.
  - d. Choosing **Fault** means **AL3** will activate when a sensor or analyzer fault exists. There is no user setting to make.
8. The display returns to the **Alarm Configure?** screen. Select another alarm or press EXIT to return to the previous screen. To return to the main display, press MENU followed by EXIT.

## 7.4.4 Procedure: Programming Alarm Setpoints

To choose a menu item, move the cursor to the item and press ENTER.  
To store a number or setting, press ENTER.

Calibrate	Hold
<b>Program</b>	Display

1. Press MENU. The main menu screen appears. Choose **Program**.

Outputs	<b>Alarms</b>
Measurement	>>

2. Choose **Alarms**.

<b>Alarm Setpoints</b>
Alarm Configure

3. Choose **Alarm Setpoints**.

Select Alarm?
<b>AL1</b> AL2            AL3

4. Choose Alarm 1 (**AL1**), Alarm 2 (**AL2**), or Alarm 3 (**AL3**).

AL1 S1 Setpoint?
High <b>20.00PPM</b>

5. The display shows the alarm selected (**AL1**) and the configuration. The alarm is for Sensor 1 (**S1**), and the logic is high. Use the arrow keys to change the high and low alarm setpoints.

6. The display returns to the **Select Alarm?** screen. Select another alarm or press EXIT to return to the previous screen. To return to the main display, press MENU followed by EXIT.

## 7.5 SELECTING THE TYPE OF MEASUREMENT

### 7.5.1 Purpose

This section describes how to do the following:

1. Program the Solu Comp II to measure total chlorine. This step is necessary because the analyzer can be used with other sensors to measure other chlorine oxidants.
2. Determine the level of electronic filtering of the sensor current
3. Enable or disable dual slope calibration

### 7.5.2 Definitions — Chlorine

1. **FREE CHLORINE.** Free chlorine is the result of adding sodium hypochlorite (bleach), calcium hypochlorite (bleaching powder), or chlorine gas to fresh water. Free chlorine is the sum of hypochlorous acid (HOCl) and hypochlorite ion (OCl<sup>-</sup>).
2. **TOTAL CHLORINE.** Total chlorine is the sum of free and combined chlorine. Combined chlorine generally refers to chlorine oxidants in which chlorine is combined with ammonia or organic amines. Monochloramine, used to disinfect potable water, is an example of combined chlorine. The term total chlorine also refers to other chlorine oxidants such as chlorine dioxide. To measure total chlorine the sample must first be treated with a mixture of acetic acid and potassium iodide. Total chlorine reacts with iodide to produce an equivalent amount of iodine, which the sensor measures.
3. **MONOCHLORAMINE.** Monochloramine (NH<sub>2</sub>Cl) is a type of combined chlorine. It is produced by the reaction between ammonia and chlorine (or sodium hypochlorite). Monochloramine is used extensively for drinking water disinfection in the United States.
4. **INPUT FILTER.** Before converting the sensor current to a chlorine reading, the Solu Comp II applies an input filter. The filter reduces noisy readings, but increases the response time. The level of filtering is selected by choosing the amount of time required for the display to reach 63% of a step change.
5. **DUAL SLOPE CALIBRATION.** The Model 499ACL-02 (total chlorine) sensor loses sensitivity at high concentrations of chlorine. The Solu Comp II has a dual slope feature that allows the user to compensate for the non-linearity of the sensor. For the vast majority of applications, dual slope calibration is unnecessary.

### 7.5.3 Procedure.

To choose a menu item, move the cursor to the item and press ENTER.

To store a number or setting, press ENTER.

Calibrate	Hold
<b>Program</b>	Display

1. Press MENU. The main menu screen appears. Choose **Program**.

Outputs	Alarms
<b>Measurement</b>	>>

2. Choose **Measurement**.

S1 Chlorine Type	
<b>free</b>	total >>

3. Choose **total**.

Input filter?
63% in 005sec

4. Choose the amount of filtering desired.

Dual Range Cal?	
<b>Disable</b>	Enable

5. Enable or disable dual slope calibration. In the vast majority of applications, dual slope calibration is unnecessary.

6. The display returns to the screen shown in step 3.

## 7.6 CHOOSING TEMPERATURE UNITS AND MANUAL OR AUTOMATIC TEMPERATURE COMPENSATION

### 7.6.1 Purpose

This section describes how to do the following:

1. Choose temperature display units (°C or °F).
2. Choose automatic or manual temperature compensation for membrane permeability.
3. Enter a temperature for manual temperature compensation.

### 7.6.3 Definitions

#### 1. AUTOMATIC TEMPERATURE COMPENSATION.

The total chlorine sensor is a membrane-covered amperometric sensor. The permeability of the membrane is a function of temperature. As temperature increases, membrane permeability increases. Thus, an increase in temperature will cause the sensor current and the analyzer reading to increase even though the chlorine level remained constant. A correction equation in the analyzer software automatically corrects for changes in membrane permeability. In automatic temperature compensation, the analyzer uses the temperature measured by the sensor for the correction.

#### 2. MANUAL TEMPERATURE COMPENSATION.

In manual temperature compensation, the analyzer uses the temperature entered by the user for membrane permeability correction. It does not use the actual process temperature. Do NOT use manual temperature compensation unless the measurement and calibration temperatures differ by no more than about 2°C. Manual temperature compensation is useful if the sensor temperature element has failed and a replacement sensor is not available.

### 7.6.3 Procedure.

To choose a menu item, move the cursor to the item and press ENTER.

To store a number or setting, press ENTER.

Calibrate	Hold
<b>Program</b>	Display

1. Press MENU. The main menu screen appears. Choose **Program**.

Outputs	Alarms
Measurement	>>

2. Choose >>.

<b>Temp</b>	Security
#Sensors	>>

3. Choose **Temp**.

Conf19 Temp?	
°C/F	Live/Manual

4. Choose **°C/F** to change temperature units. Choose **Live/Manual** to turn on (Live) or turn off (Manual) automatic temperature compensation.
  - a. If **°C/F** is chosen, select **°C** or **°F** in the next screen.
  - b. If **Live/Manual** is chosen, select **Live** or **Manual** in the next screen.
  - c. If **Manual** is chosen, enter the temperature in the next screen. The temperature entered in this step will be used in all subsequent measurements, no matter what the process temperature is.

## 7.7 SETTING A SECURITY CODE

### 7.7.1 Purpose.

This section describes how to set a security code. The security code prevents program and calibration settings from accidentally being changed. Refer to Section 6.4 for additional information.

### 7.7.2 Procedure.

**To choose a menu item, move the cursor to the item and press ENTER.**  
**To store a number or setting, press ENTER.**

Calibrate	Hold
<b>Program</b>	Display

1. Press MENU. The main menu screen appears. Choose **Program**.

Outputs	Alarms
Measurement	>>

2. Choose >>, then **Security**.

Temp	<b>Security</b>
#Sensors	>>

3. Enter a three digit security code. The security code takes effect two minutes after the last key stroke.
4. The display returns to the security menu screen. Press EXIT to return to the previous screen. To return to the main display, press MENU followed by EXIT.

## 7.8 NOISE REJECTION

### 7.8.1 Purpose.

For maximum noise rejection, the frequency of the ac power must be entered in the analyzer.

### 7.8.2. Procedure.

**To choose a menu item, move the cursor to the item and press ENTER.**  
**To store a number or setting, press ENTER.**

Calibrate	Hold
<b>Program</b>	Display

1. Press MENU. The main menu screen appears. Choose **Program**.

<b>Outputs</b>	Alarms
Measurement	>>

2. Choose >>.

<b>Temp</b>	Security
#Sensors	>>

3. Choose >>.

<b>Noise Rejection</b>	
ResetAnalyzer	>>

4. Choose **Noise Rejection**.
5. Enter the mains frequency, 50 Hz or 60 Hz.
6. The display returns to the **Noise Rejection** screen. To return to the main menu, press EXIT. To return to the main display, press MENU followed by EXIT.

## 7.9 RESETTING FACTORY CALIBRATION AND FACTORY DEFAULT SETTINGS

### 7.9.1 Purpose.

This section describes how to re-install factory calibration and default values. The process also clears all fault messages and returns the display to the first quick start screen.

### 7.9.2. Procedure.

To choose a menu item, move the cursor to the item and press ENTER.  
To store a number or setting, press ENTER.

Calibrate	Hold
<b>Program</b>	Display

1. Press MENU. The main menu screen appears. Choose **Program**.

<b>Outputs</b>	Alarms
Measurement	>>

2. Choose >>.

<b>Temp</b>	Security
#Sensors	>>

3. Choose >>.

Noise Rejection	
ResetAnalyzer	>>

4. Choose **ResetAnalyzer**.

Load factory settings?	<b>Yes</b>	No
------------------------	------------	----

5. Choose **Yes** or No. If **Yes** is selected, previous settings are cleared and the **Quick Start Menu** appears.

## 7.10 SELECTING A DEFAULT SCREEN, LANGUAGE, AND SCREEN CONTRAST

### 7.10.1 Purpose

This section describes how to do the following:

1. set a default display screen
2. select a language
3. change the screen contrast

To choose a menu item, move the cursor to the item and press ENTER.  
To store a number or setting, press ENTER.

### 7.10.2 Procedure: Selecting a Display Screen

Calibrate	Hold
Program	<b>Display</b>

<b>Default Display</b>	
Language	Contrst

1. Press MENU. The main menu screen appears. Choose **Display**.
2. Choose **Default Display**.
3. Press  $\leftarrow$  or  $\rightarrow$  until the desired display appears. Press ENTER.
4. The display returns to the screen in step 2. To return to the main menu, press MENU. To return to the main display, press MENU followed by EXIT.

### 7.10.3 Procedure: Choosing a Language

Calibrate	Hold
Program	<b>Display</b>

Default Display	
<b>Language</b>	Contrast

<b>English</b>	Fran ais
Espa ol	>>

1. Press MENU. The main menu screen appears. Choose **Display**.
2. Choose **Language**.
3. Choose **English, Français, Español, Deutsch, Italiano, or Portugues**.
4. The display returns to the screen in step 2. To return to the main menu, press MENU. To return to the main display, press MENU followed by EXIT.

### 7.10.2 Procedure: Changing Screen Contrast

Calibrate	Hold
Program	<b>Display</b>

Default Display	
Units	<b>Contrst</b>

Screen Contrast:
<b>50</b>

1. Press MENU. The main menu screen appears. Choose **Display**.
2. Choose **Contrst**.
3. Press  $\leftarrow$  or  $\rightarrow$  to increase or decrease the screen contrast. As contrast increases, the number increases.
4. The display returns to the screen shown in step 2. To return to the main menu, press MENU. To return to the main display, press MENU followed by EXIT.

## SECTION 8. CALIBRATION

### 8.1 INTRODUCTION

The Calibrate Menu allows the user to calibrate the total chlorine sensor. Both the ppm reading and the temperature can be calibrated.

Total chlorine sensors require periodic full-scale calibration. The purpose of the full-scale standard is to establish the slope of the calibration curve. Because stable chlorine standards do not exist, **the sensor must be calibrated against a test run on a grab sample of the process liquid.** Several manufacturers offer portable test kits for this purpose.

New chlorine sensors must be zeroed before being placed in service. Sensors should also be zeroed every time the electrolyte solution is replaced. Zeroing involves placing the sensor in a chlorine-free sample until the sensor current drops to its lowest stable value.

### 8.2 CALIBRATING TEMPERATURE

#### 8.2.1 Purpose

The total chlorine sensor is a membrane-covered amperometric sensor. As the sensor operates, iodine, produced by the reaction between total chlorine and the vinegar/potassium iodide reagent, diffuses through the membrane and is consumed at an electrode immediately behind the membrane. The reaction produces a current that depends on the rate at which iodine diffuses through the membrane. The diffusion rate, in turn, depends on the concentration of the iodine and how easily it passes through the membrane (the membrane permeability). Because membrane permeability is a function of temperature, the sensor current will change if either the concentration or temperature changes. To account for changes in sensor current caused by temperature alone, the analyzer automatically applies a membrane permeability correction. The membrane permeability changes about 3%/°C at 25°C, so a 1°C error in temperature produces about a 3% error in the reading.

Without calibration the accuracy of the temperature measurement is about  $\pm 0.4^\circ\text{C}$ . Calibrate the sensor/analyzer unit if...

1.  $\pm 0.4^\circ\text{C}$  accuracy is not acceptable
2. the temperature measurement is suspected of being in error. Calibrate temperature by making the analyzer reading match the temperature measured with a **standard thermometer**.

**8.2.2 Procedure**

1. Remove the sensor from the process. Place it in an insulated container of water along with a **calibrated thermometer**. Submerge at least the bottom two inches of the sensor. Stir continuously.
2. Allow the sensor to reach thermal equilibrium. The time constant for a change in temperature is about 5 min., so it may take as long as 30 min. for temperature equilibration.
3. Change the Solu Comp II display to match the **calibrated thermometer** using the procedure below.

<b>Calibrate</b>	Hold
Program	Display

- a. Press MENU. The main menu screen appears. Choose **Calibrate**.

CalSensor1?	
Measurement	<b>Temp</b>

- b. Choose **Temp**.

Live	25.0°C
CalS1	+25.0°C

- c. If the analyzer was programmed in Section 5.6 to use the actual process temperature, the screen at left will appear. To calibrate the temperature, change the number in the second line to match the temperature measured with the **standard thermometer**. Press ENTER. Go to step e.

If the calibration temperature is more than 2 or 3°C different from the live reading, see Section 10.3.7.

If the analyzer was programmed to use a temperature entered by the user, go to step d.

ManualTemp?	
S1: +25.0°C	

- d. The screen at left will appear. Change the temperature to the desired value, then press ENTER. The analyzer will use the temperature entered in this step in all measurements and calculations, no matter what the true temperature is.

CalSensor1?	
Measurement	<b>Temp</b>

- e. The screen at left will appear. Press EXIT.

- f. To return to the main display, press MENU followed by EXIT.

## 8.3 CALIBRATION

### 8.3.1 Purpose

The continuous determination of total chlorine requires two steps. See Figure 8-1. First, the sample flows into a conditioning system (The Model TCL) where it is treated with acetic acid (vinegar) and potassium iodide. The acid lowers the pH, which allows total chlorine in the sample to quantitatively oxidize the iodide to iodine. The treated sample then flows to the sensor. The sensor is a membrane-covered amperometric sensor, whose output is proportional to the concentration of iodine. Because the concentration of iodine is proportional to the concentration of total chlorine, the analyzer can be calibrated to read total chlorine.

Figure 8-2 shows a typical calibration curve for a total chlorine sensor. Because the sensor really measures iodine, calibrating the sensor requires exposing it to a solution containing no iodine (zero standard) and to a solution containing a known amount of iodine (full-scale standard).

The zero standard is necessary because the sensor, even when no iodine is present, generates a small current called the residual current. The analyzer compensates for the residual current by subtracting it from the measured current before converting the result to a total chlorine value. New sensors require zeroing before being placed in service, and sensors should be zeroed whenever the electrolyte solution is replaced. Deionized water is a good zero standard.

The purpose of the full-scale standard is to establish the slope of the calibration curve. Because stable total chlorine standards do not exist, the sensor must be calibrated against a test run on a grab sample of the process liquid. Several manufacturers offer portable test kits for this purpose. Observe the following precautions when taking and testing the grab sample.

- Take the grab sample from a point as close as possible to the inlet of the TCL sample conditioning system.
- Total chlorine solutions are unstable. Run the test immediately after taking the sample. Try to calibrate the sensor when the chlorine concentration is at the upper end of the normal operating range.

The Model 499ACL-02 (total chlorine) sensor loses sensitivity at high concentrations of chlorine. The Solu Comp II has a dual slope feature that allows the user to compensate for the non-linearity of the sensor. However, for the vast majority of applications, dual slope calibration is unnecessary.

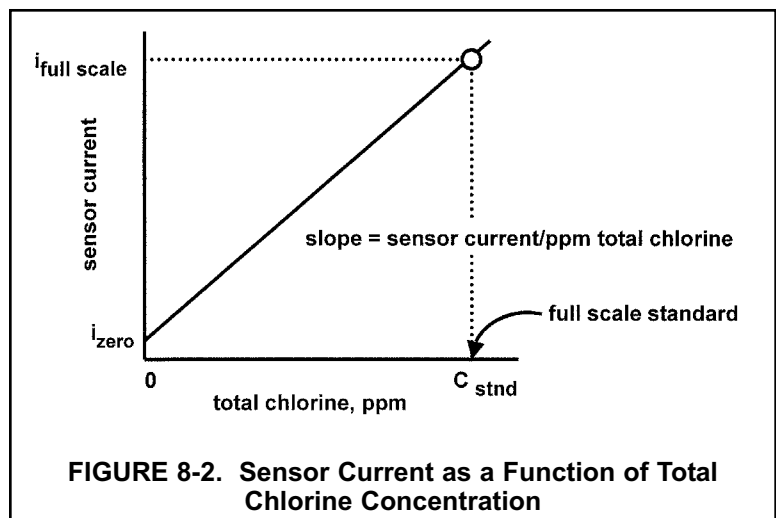
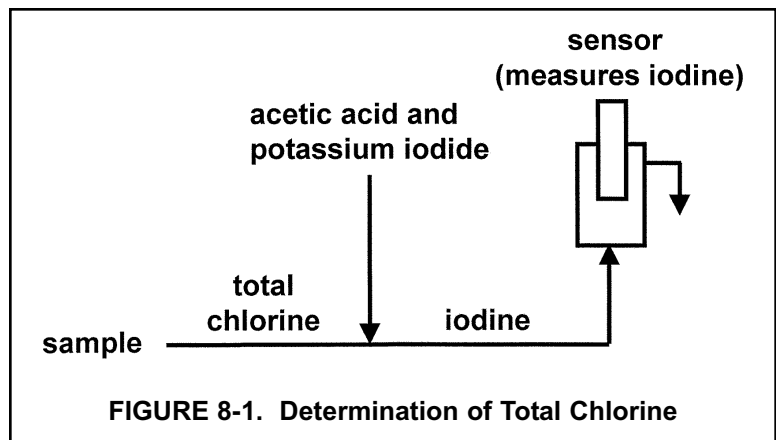

**8.3.2 Procedure — Zeroing the sensor.**

1. Place the sensor in a beaker of deionized water.
2. Let the system run until the current is stable. The sensor current will drop rapidly at first and then gradually reach a stable zero value. To monitor the sensor current, go to the main display press ▼ until the sensor input current is showing. Typical sensor current for a total chlorine sensor is -10 to +50 nA.

A new sensor or a sensor in which the electrolyte solution has been replaced may require several hours (occasionally as long as overnight) to reach a minimum zero current. DO NOT START THE ZERO ROUTINE UNTIL THE SENSOR HAS BEEN IN THE ZERO SOLUTION FOR AT LEAST TWO HOURS.

<b>Calibrate</b>	Hold
Program	Display

3. Press MENU. The main menu screen appears. Choose **Calibrate**.

CalSensor1?	
<b>Measurement</b>	TEMP

4. Choose **Measurement**.

Cal S1?	
InProcess	<b>Zero</b>

5. Choose **Zero**.

S1 Live	1.000PPM
Zeroing	<b>Wait</b>

6. The screen at left appears. The top line is the current chlorine reading based on the previous calibration or, for a first time calibration, the default sensitivity.

S1 Live	0.000PPM
Sensor Zero Done	

7. Once the reading is stable, the screen at left appears. Sensor zero is complete and the analyzer has stored the zero current. The screen remains until the operator presses MENU then EXIT to return to the main display.

**NOTE**

Pressing ENTER during the zero step will cause the analyzer to use the present sensor current as the zero current. If the sensor is zeroed before the current has reached a minimum stable value, subsequent readings will be in error.

After zeroing, leave the sensor in the zero solution and verify that the sensor current is between -10 and +50 nA. To display the sensor current, go to the main display and press ▼ until the input current is showing.

Sensor Zero Fail	
Current Too High	

8. This screen appears if the zero current is extremely high. See Section 10.3 for troubleshooting. To repeat the zero step, press EXIT and choose **Zero**.

Possible ZeroErr	
Proceed? Yes	<b>No</b>

9. This screen appears if the zero current is moderately high. To continue, choose **Yes**. To repeat the zero step, choose **No**.

8.3.3 Procedure — Calibrating the sensor (single slope)

NOTE

Single slope calibration is the commonly used calibration method for total chlorine. Dual slope calibration, described in Section 8.3.4, is rarely needed.

1. If the sensor was just zeroed, place the sensor back in the flow cell. Confirm that excess sample is flowing down the inside tube of the overflow sampler. Also, verify that reagent is being delivered to the sample and that the air pump is working.
2. Adjust the chlorine concentration until it is near the upper end of the control range. Wait until the analyzer reading is stable before starting the calibration. When the TCL is first started up or when a new sensor is put in service, allow at least 30 minutes for the reading to stabilize.

<b>Calibrate</b>	Hold
Program	Display

CalSensor1?	
<b>Measurement</b>	TEMP

Cal S1?	
<b>InProcess</b>	Zero

Live	10.000PPM
Cal S1	10.000PPM

3. Press MENU. The main menu screen appears. Choose **Calibrate**.
4. Choose **Measurement**.
5. Choose **InProcess**.
6. The screen shown at left appears. The top line is the current chlorine reading based on the previous calibration.

Sample the process liquid. Make a note of the reading before taking the sample. Immediately determine free chlorine. Note the analyzer reading again. If the present reading (X) differs from the reading when the sample was taken (Y), calculate the value to enter (C) from the following formula:

$$C = (X/Y) (A)$$

where A is the concentration of chlorine in the grab sample.

Change the reading in the second line to match the results of the grab sample test.

7. During calibration, the analyzer stores the measured current and calculates the sensitivity. Sensitivity is sensor current in nA divided by the concentration of chlorine. The sensitivity of a 499ACL-02 (total chlorine) sensor is 1100-2200 nA/ppm at 25°C.

Possible Cal Err	
Proceed? Yes	<b>No</b>

8. This screen appears if the sensitivity is much higher or lower than expected. See Section 10.3 for troubleshooting. To repeat the calibration step, press EXIT and choose **InProcess**.

Calibration	
Error	

9. This screen appears if the sensitivity is moderately higher or lower than expected. To continue, choose **Yes**. To repeat the calibration, choose **No**. For troubleshooting assistance, see Section 10.3.

**8.3.4 Procedure — Calibrating the sensor (dual slope)**

Figure 8-3 shows the principle of dual slope calibration. Between zero and concentration C1, the sensor response is linear. When the concentration of chlorine becomes greater than C1, the response is non-linear. In spite of the non-linearity, the response can be approximated by a straight line between point 1 and point 2.

Dual slope calibration is rarely needed. It is probably useful in fewer than 5% of applications.

1. Place the sensor in a beaker of distilled water.
2. Let the system run until the current is stable. The sensor current will drop rapidly at first and then gradually reach a stable zero value. To monitor the sensor current, go to the main display and press ▼ until the sensor input current is showing. Typical sensor current for a total chlorine sensor is -10 to +50 nA.

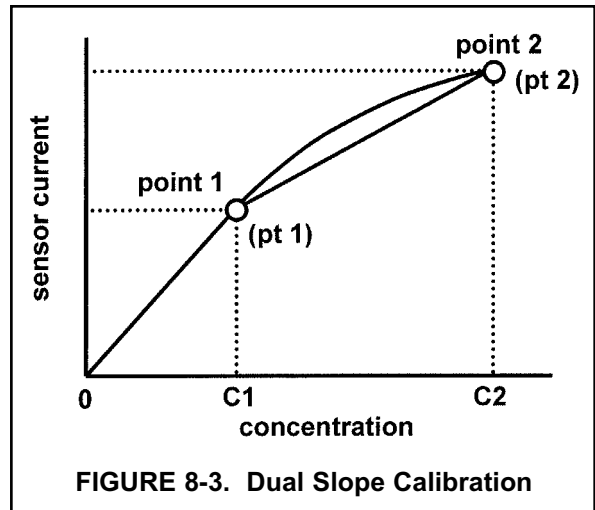

**FIGURE 8-3. Dual Slope Calibration**

A new sensor or a sensor in which the electrolyte solution has been replaced may require several hours (occasionally as long as overnight) to reach a minimum zero current. **DO NOT START THE ZERO ROUTINE UNTIL THE SENSOR HAS BEEN IN ZERO SOLUTION FOR AT LEAST TWO HOURS.**

3. Be sure the analyzer has been configured for dual slope calibration. See Section 7.5.2.

<b>Calibrate</b>	Hold
Program	Display

4. Press MENU. The main menu screen appears. Choose **Calibrate**.

CalSensor1?	
<b>Measurement</b>	TEMP

5. Choose **Measurement**.

Cal S1?		
<b>Zero</b>	pt1	pt2

6. Choose **Zero**.

S1 Live	1.000PPM
Zeroing	<b>Wait</b>

7. The screen at left appears. The top line is the current chlorine reading based on the previous calibration or, for a first time calibration, the default sensitivity.

S1 Live	0.000PPM
Sensor	Zero Done

8. Once the reading is stable, the screen at left appears. Sensor zero is complete, and the analyzer has stored the zero current. The screen remains until the operator presses EXIT to return to the screen in step 9. If a "Sensor zero fail" or "Possible zero error" screen appears, refer to Section 10.3 -Troubleshooting.

Cal S1?		
Zero	<b>pt1</b>	pt2

9. Place the sensor back in the flow cell. Confirm that excess sample is flowing down the inside tube of the overflow sampler. Also verify that reagent is being delivered to the sample and that the air pump is working.

Adjust the concentration of chlorine until it is near the upper end of the linear response range of the sensor (pt1 in Figure 8-3).

S1 Live	10.00PPM
<b>pt1</b>	10.00PPM

10. Choose **pt1**. The screen at left appears. The top line is the current chlorine reading based on the previous calibration or, for a first time calibration, the default sensitivity.

11. Wait until the reading is stable.

Sample the process liquid. Make a note of the reading before taking the sample. Immediately determine free chlorine. Note the analyzer reading again. If the present reading (X) differs from the reading when the sample was taken (Y), calculate the value to enter (C) from the following formula:

$$C = (X/Y) (A)$$

where A is the concentration of chlorine in the grab sample.

Change the reading in the second line to match the results of the grab sample test.

Cal S1?		
Zero	pt1	<b>pt2</b>

12. The screen returns to the display in step 9.

13. Adjust the concentration of chlorine until it is near the top end of the range (pt2 in Figure 8-3).

S1 Live	10.00PPM
<b>pt2</b>	10.00PPM

14. Choose **pt2**. The screen at left appears. The top line is the current chlorine reading based on the previous calibration or, for a first time calibration, the default sensitivity.

15. Following the procedure in step 11, determine chlorine in a sample of the process liquid. Change the reading in the second line to match the results of the grab sample test.

16. The display returns to the screen in step 9. Press MENU followed by EXIT to return to the main display.

## SECTION 9. MAINTENANCE

### 9.1 1055 ANALYZER

The 1055 analyzer requires little routine maintenance.

Clean the analyzer case and front panel by wiping with a clean soft cloth dampened with water ONLY. Do not use solvents, like alcohol, that might cause a buildup of static charge.

Only a few components of the analyzer are replaceable. See Tables 9-1 and 9-2 and Figures 9-1 and 9-2.

Circuit boards are not replaceable.

**TABLE 9-1. Replacement Parts for 1055 Analyzer (Panel Mount Version)**

Location in Figure 9-1	PN	Description	Shipping Weight
1	23823-00	Panel mounting kit, includes four brackets and four set screws	2 lb/1.0 kg
2	33654-00	Gasket, front, for panel mount version	2 lb/1.0 kg
3	33658-00	Gasket, rear cover, for panel mount version	2 lb/1.0 kg
4	note	Self-tapping screws, #6 x 1.25 in.	

*Note: Information about the size of screws and O-rings is for information only. Screws and washers cannot be purchased from Rosemount Analytical.*

*Shipping weights are rounded up to the nearest whole lb or 0.5 kg.*

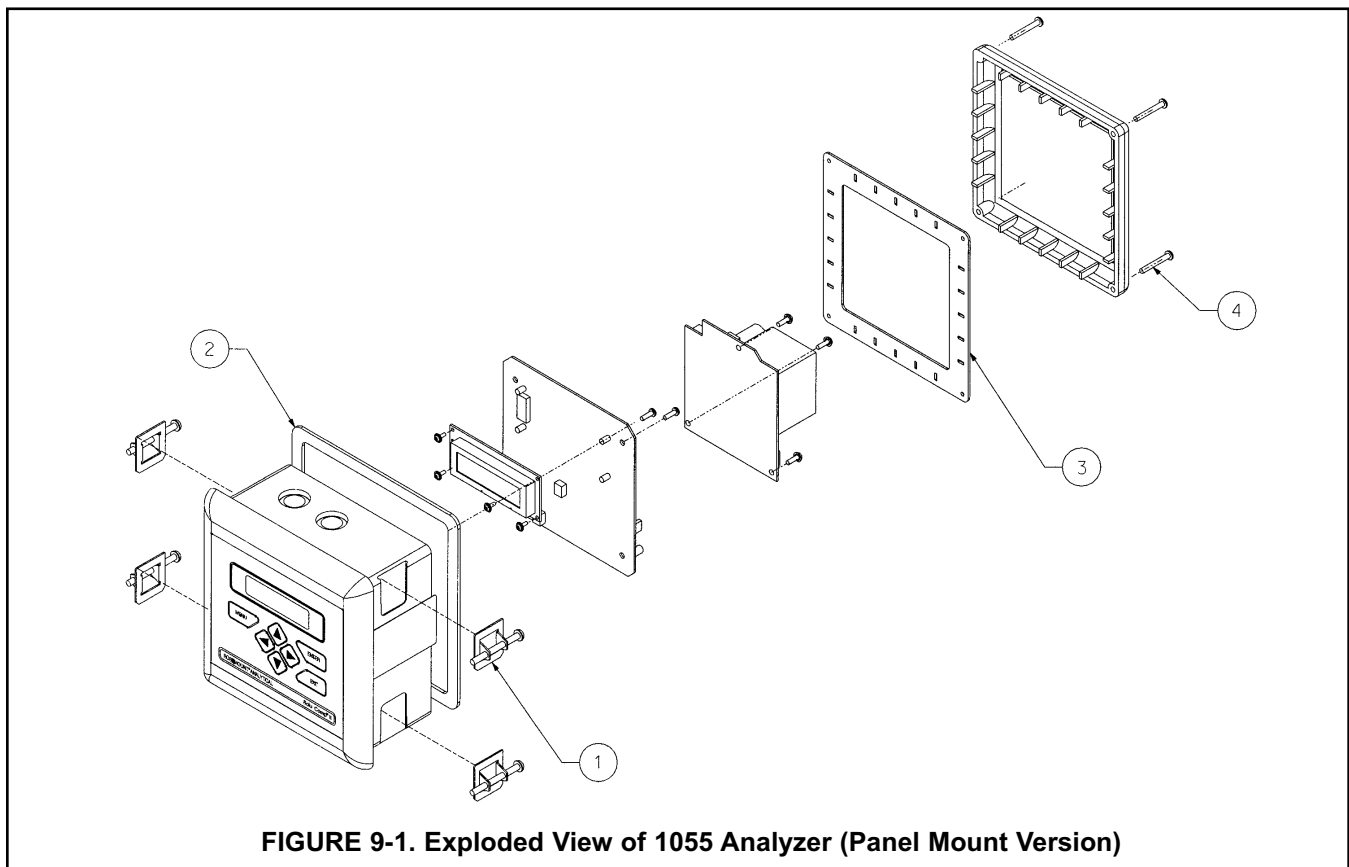

**TABLE 9-2. Replacement Parts for 1055 Analyzer (Wall Mount Version)**

Location in Figure 9-2	PN	Description	Shipping Weight
1	note	Screw, 6-32 x 1.38 in.	
2	note	O-ring 2-007	
3	33655-00	Gasket for pipe/surface mount version	2 lb/1.0 kg
not shown	23833-00	Surface mount kit; consists of four self-tapping screws #6 x 1.75 in. and four O-rings	1 lb/0.5 kg

Note: Information about the size of screws and O-rings is for information only. Screws and washers cannot be purchased from Rosemount Analytical.  
Shipping weights are rounded up to the nearest whole lb or 0.5 kg.

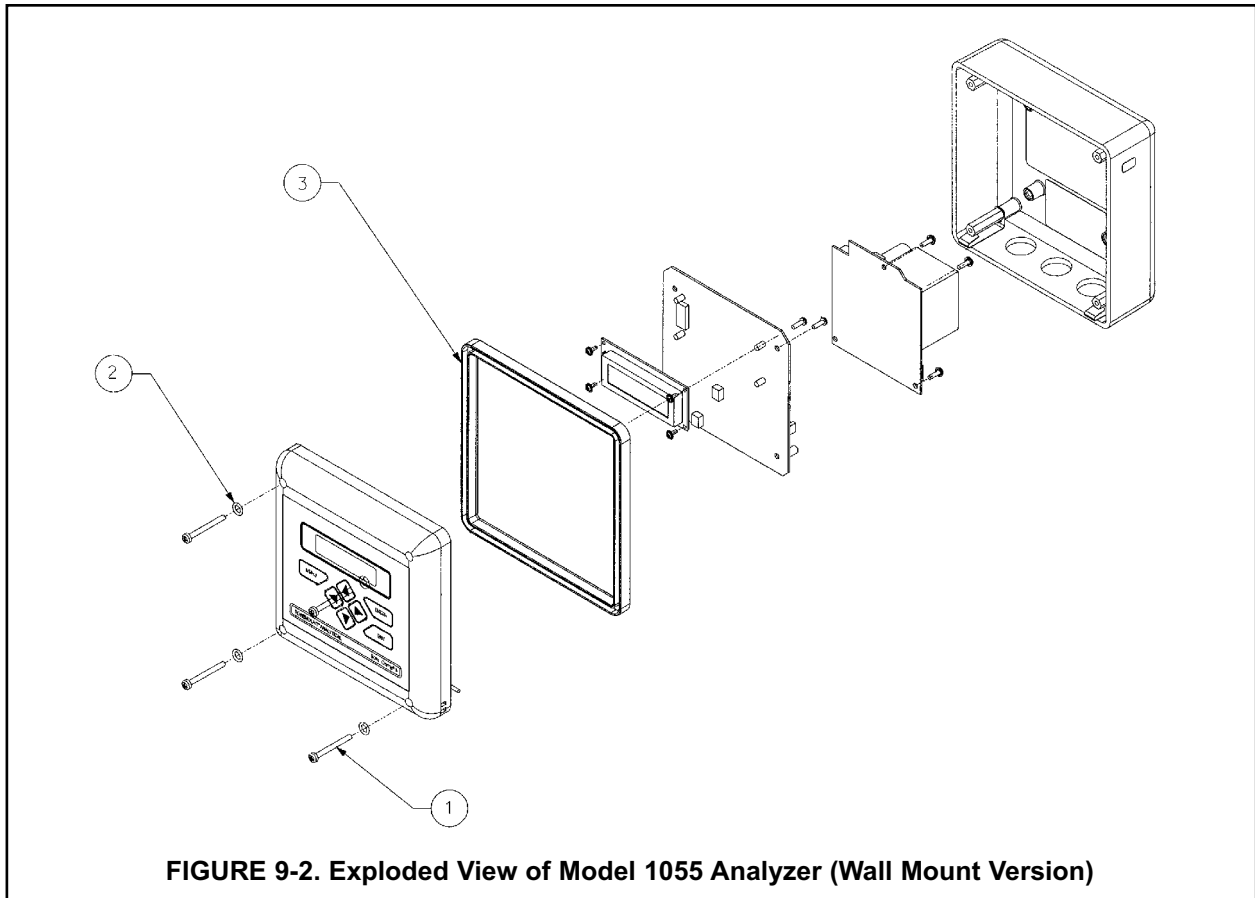

## 9.2 TOTAL CHLORINE SENSOR

### 9.2.1 General

When used in clean water, the total chlorine sensor requires little maintenance. Generally, the sensor needs maintenance when the response becomes sluggish or noisy or when readings drift follow calibration. Maintenance frequency is best determined by experience. If the sensor is used in potable water, expect to clean the membrane every month and replace the membrane and electrolyte solution every three months. Sensors used in dirty water require more frequent maintenance and calibration. However, if experience shows the sensor is holding calibration and not drifting appreciably between calibration intervals, the maintenance interval can be extended.

### 9.2.2 Cleaning the membrane.

Keep the membrane clean. Clean the membrane with water sprayed from a wash bottle. Use a soft tissue to **gently** wipe the membrane.

### 9.2.3 Replacing the membrane.

1. Hold the sensor with the membrane facing up.
2. Unscrew membrane retainer. Remove the membrane assembly and O-ring. See Figure 9-3.
3. Inspect the cathode. If it is tarnished, clean it by gently rubbing in the direction of the existing scratches (do not use a circular motion) with 400-600 grit silicon carbide finishing paper. Rinse the cathode thoroughly with water.
4. Put a new O-ring in the groove. Hold the membrane assembly with the cup formed by the membrane and membrane holder pointing up. Fill the cup with electrolyte solution.
5. Next, place a drop of electrolyte solution on the cathode. Invert the membrane assembly and place it over the cathode stem.
6. Screw the membrane retainer back in place.
7. Hold the sensor with the membrane pointing down. Shake the sensor a few times, as though shaking down a clinical thermometer.

**CAUTION**

Fill solution may cause irritation.  
Avoid contact with skin and eyes.  
May be harmful if swallowed.

### 9.2.4 Preparing the fill solution

The fill solution in the total chlorine sensor (Model 499ACL-02) is potassium iodide in a phosphate buffer. The fill solution has a limited shelf life and should be prepared immediately before use. The sensor is shipped with enough reagents to prepare three batches of fill solution.

To prepare the fill solution:

1. Pour the potassium iodide crystals (PN R-434A) into the bottle containing the phosphate buffer (PN R-434S).
2. Cap the bottle and invert a few times until the crystals dissolve. Potassium iodide dissolves rapidly.
3. Transfer the solution to the flip-top dispensing bottle. Use the dispensing bottle to fill the sensor. See Section 9.2.5.

**9.2.5 Replacing the membrane and electrolyte solution.**

1. Unscrew the membrane retainer and remove the membrane assembly and O-ring. See Figure 9-3.
2. Hold the sensor over a container with the cathode pointing down.
3. Remove the fill plug and allow the electrolyte solution to drain out.
4. Wrap the plug with several turns of pipe tape and set aside.
5. Prepare a new membrane. Hold the membrane assembly with the cup formed by the membrane and membrane holder pointing up. Fill the cup with electrolyte solution.
6. Hold the sensor at about a 45-degree angle with the cathode end pointing up. Add electrolyte solution (see Section 9.2.4) through the fill hole until the liquid overflows. Tap the sensor near the threads to release trapped air bubbles. Add more electrolyte solution if necessary.
7. Place the fill plug in the electrolyte port and begin screwing it in. After several threads have engaged, rotate the sensor so that the cathode is pointing up and continue tightening the fill plug. Do not overtighten.
8. Place a new O-ring in the groove around the cathode post. Cover the holes at the base of the cathode stem with several drops of electrolyte solution.
9. Insert a small **blunt** probe, like a toothpick with the end cut off, through the pressure equalizing port. See Figure 9-3.

**NOTE**

**Do not use a sharp probe. It will puncture the bladder and destroy the sensor.**

Gently press the probe against the bladder several times to force liquid through the holes at the base of the cathode stem. Keep pressing the bladder until no air bubbles can be seen leaving the holes. Be sure the holes remain covered with electrolyte solution.

10. Place a drop of electrolyte solution on the cathode, then place the membrane assembly over the cathode. Screw the membrane retainer in place.
11. The sensor may require several hours operating at the polarizing voltage to equilibrate after the electrolyte solution has been replenished.

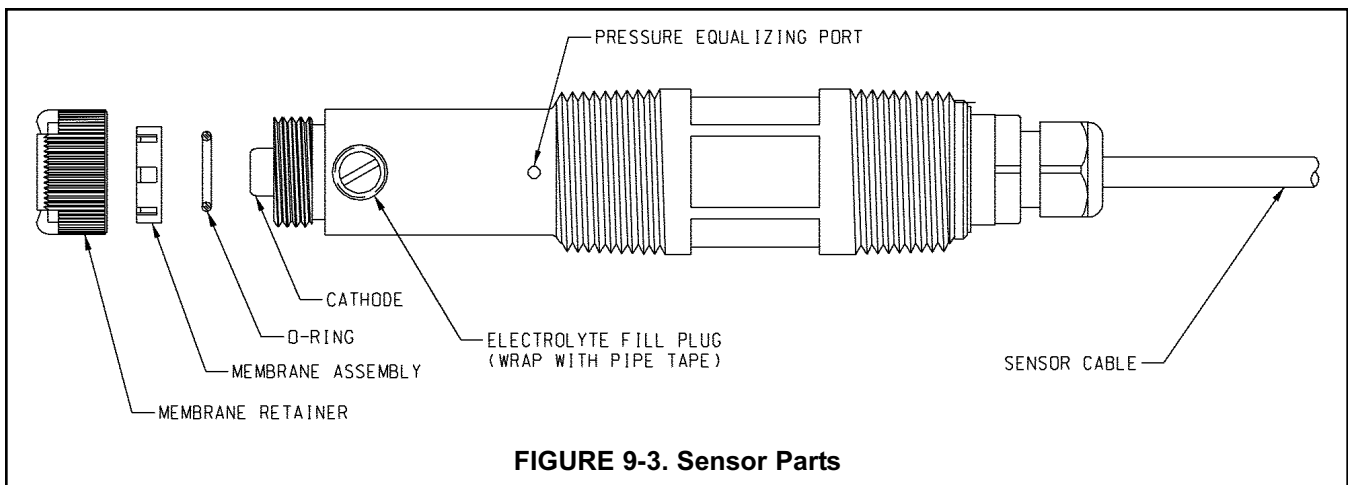
**TABLE 9-3. Spare Parts**

33523-00	Electrolyte Fill Plug
9550094	O-Ring, Viton 2-014
33521-00	Membrane Retainer
23501-02	Total Chlorine Membrane Assembly: includes one membrane assembly and one O-ring
23502-02	Total Chlorine Membrane Kit: includes 3 membrane assemblies and 3 O-rings
R-434-4OZ	Total Chlorine Sensor Fill Solution, includes buffer and KI crystals to be mixed before use, sufficient for three recharges

## 9.3 SAMPLE CONDITIONING SYSTEM

### 9.3.1 Reagent

The sample conditioning reagent lasts about 2 months. Before putting fresh reagent in the carboy, discard any small amount of remaining reagent. To prepare the reagent refer to the procedure in Section 5.1. See Table 9-4 for ordering information.

### 9.3.2 Sample and reagent tubing.

Periodically inspect sample and reagent tubing for cracks and leaks. Replace tubing if it is damaged.

After a period of time, the sample tubing may become plugged with suspended matter. The tubing is flexible and difficult to clean mechanically. Plugged sample tubing is best replaced.

Replacement tubing kits are available. See Table 9-4 for part numbers.

To replace reagent tubing:

1. Reagent tubing is shown in Figure 9-4.
2. Turn off sample and reagent pumps.
3. Luer fittings connect the reagent tubing to the pump. Disconnect the tubing by turning the fitting in the direction of the arrows shown in Figure 9-6.
4. Disconnect the other end of the suction tubing from the barb on the reagent inlet fitting in the bottom of the enclosure. Disconnect the other end of discharge tubing from the reagent injection tee.
5. Install the replacement tubing. Note that the discharge tubing is longer than the suction tubing.

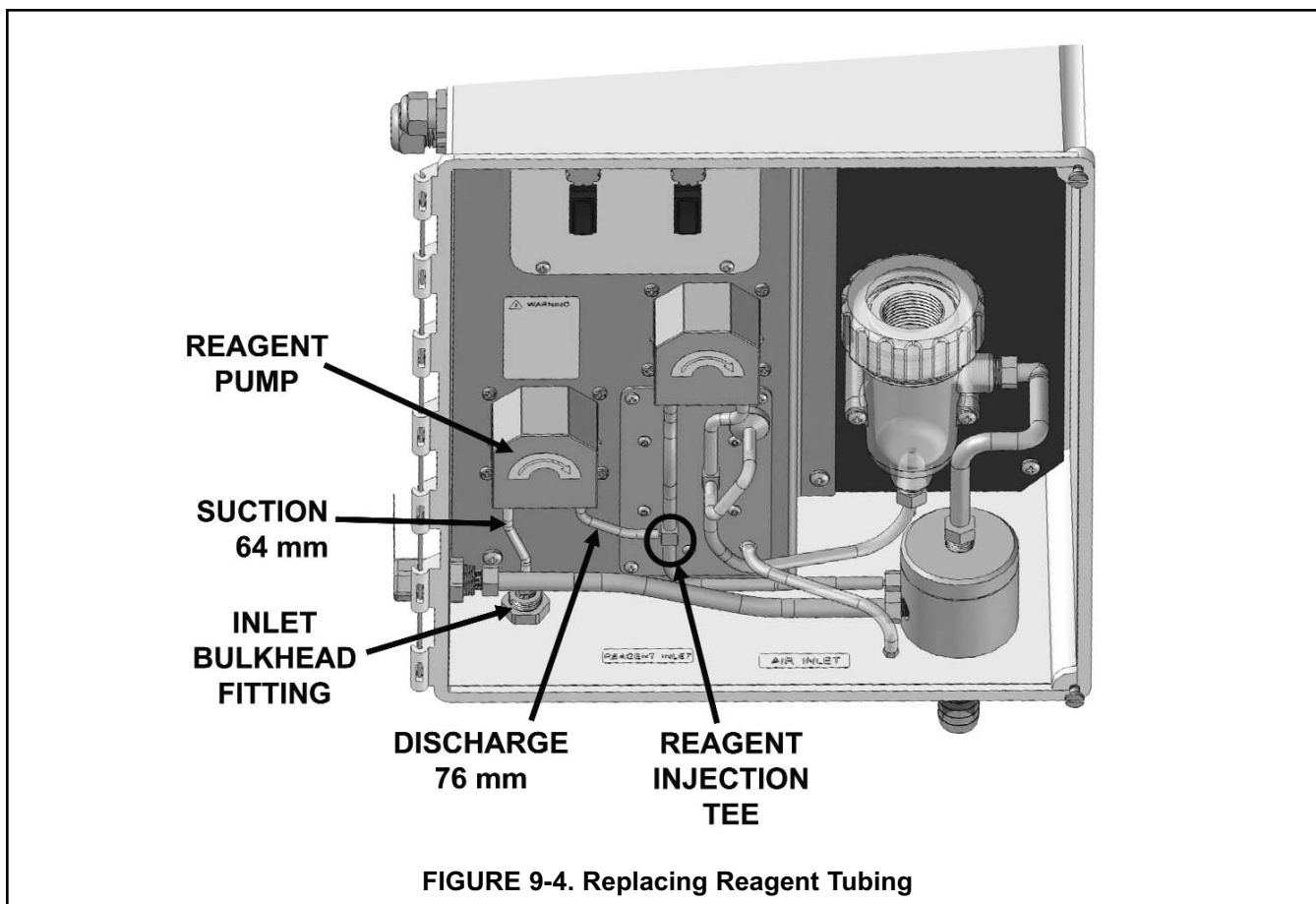

FIGURE 9-4. Replacing Reagent Tubing

To replace sample tubing:

1. Sample tubing is shown in Figure 9-5.
2. Turn off the sample and reagent pumps.
3. Luer fittings connect the sample tubing to the pump. Disconnect the tubing by turning the fitting in the direction of the arrows shown in Figure 9-6.
4. Disconnect the other end of the sample pump suction tubing from the overflow sampler. Pull the reagent injection tube off the reagent injection tee.
5. Disconnect the other end of the sample pump discharge tubing from the flow cell. Pull the air injection tube off the air injection tee.
6. Disconnect the sample inlet and drain tubing.
7. Install the replacement sample pump suction and discharge tubing assemblies. The assemblies look similar. To tell the difference, note the air injection tee in the discharge tubing assembly has a larger diameter barb than the reagent injection tee in the suction tubing assembly.
8. Install replacement sample inlet and drain tubing. The sample inlet tubing is longer than the drain tubing.

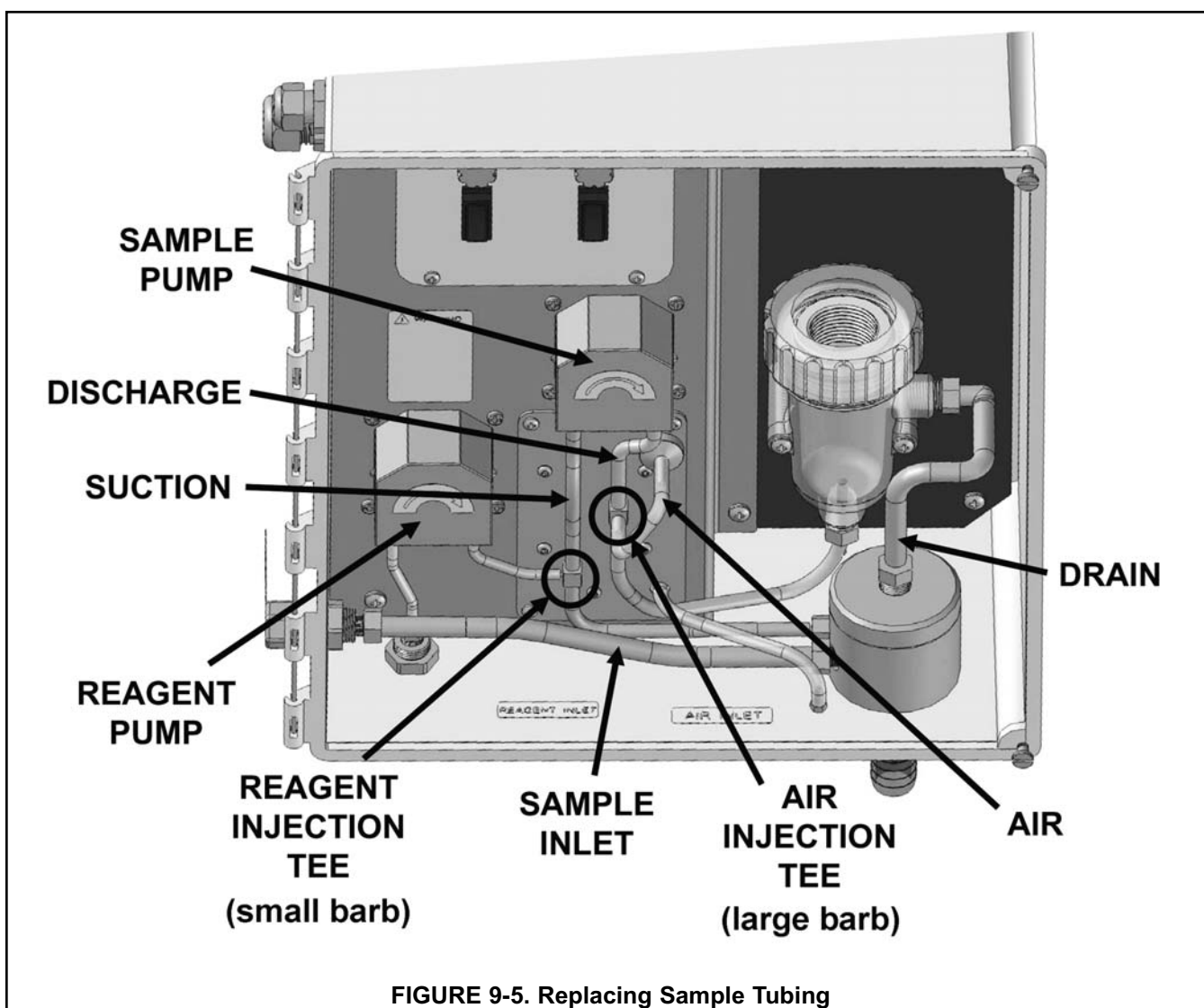

FIGURE 9-5. Replacing Sample Tubing

**9.3.3 Peristaltic pump tubing.**

The expected life of the peristaltic pump tubing is one year.

To replace pump tubing:

1. Turn off the sample and reagent pumps.
2. The reagent and sample tubing is connected to the pump tubing with luer fittings. See Figure 9-6. Disconnect the fittings from the pump by turning the fitting in the direction of the arrow.

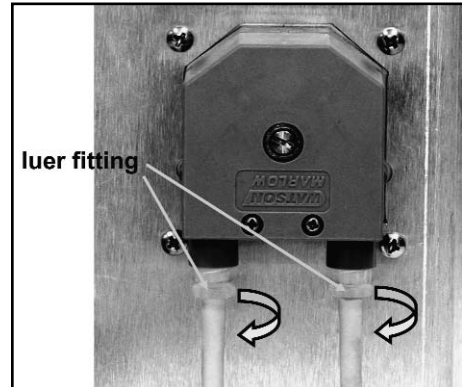

**FIGURE 9-6.**

3. Using your thumb and forefinger gently pinch the sides of the pump cover. Slide the cover upwards to remove it. See Figure 9-7.

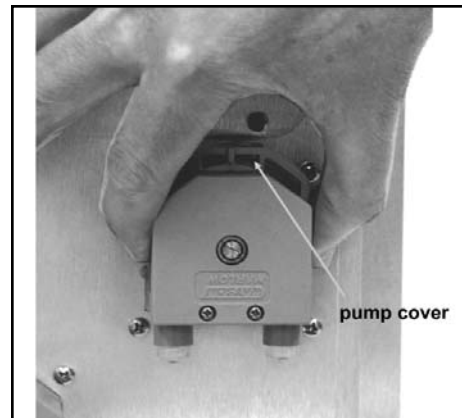

**FIGURE 9-7.**

4. Using your thumb as shown in Figure 9-8, push the tubing fitting straight outward until the fitting slides out of the socket. Repeat the process for the other fitting.

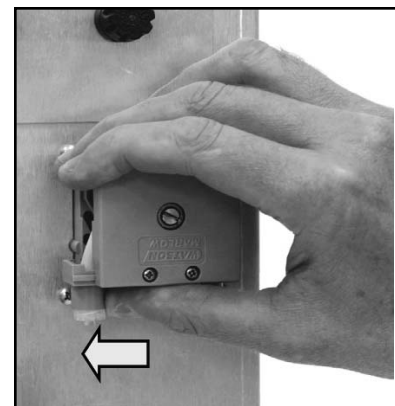

**FIGURE 9-8.**

5. Remove and discard the pump tubing.

6. Insert the new tubing one end at a time. Tongues on the sides of the gray fittings at the ends of the tube fit into receiving grooves in the pump casing. See Figure 9-9. Push the fitting into place until it clicks. Gently stretch the tubing over the rollers and insert the other fitting into the receiving socket on the other side of the pump.

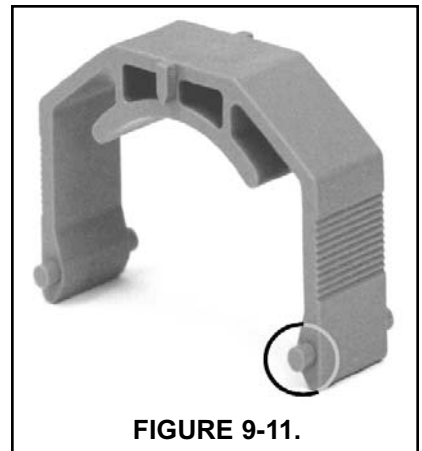

**FIGURE 9-9.**

7. Replace the pump cover.
  - a. Place the cover on the pump casing. See Figure 9-10.



- b. Be sure the pins at the bottom of the cover (Figure 9-11) ride on the tracks in the pump casing.



- c. The position of the track is outlined in Figure 9-12. The pins on the pump cover must ride in these tracks as the cover is pushed into place. Gently squeeze the ends of the cover to guide the pins.

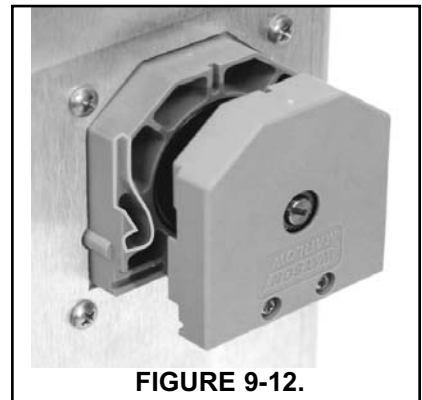

- d. Push down until the cover snaps into place.

8. Reconnect the tubing.

**9.3.4 Replacing the air pump**

1. Disconnect power to the analyzer.
2. Refer to Figure 9-13. Disconnect the reagent and air injection tubes. Disconnect the suction and discharge tubing by turning the Luer fitting in the direction shown in the figure. Disconnect the air pump inlet tubing from the barbed fitting in the bottom of the enclosure.
3. Remove the four screws (circled in Figure 9-14) holding the air pump access panel. Pull out the pump and panel.
4. Disconnect the air inlet and outlet tubing from the air pump. See Figure 9-15.
5. Remove the five screws (surrounded by squares in Figure 9-14) holding the air pump to the access panel.
6. Remove the four screws holding the wiring access panel.
7. Disconnect the air pump power wires from the terminal strip. See Figure 9-16. Discard the old air pump.
8. Remove the five screws holding the rubber base of the replacement air pump to the body.
9. Using the five screws removed in step 6, attach the replacement air pump to the access panel.
10. Connect the air pump power wires to the terminal strip.
11. Replace the wiring access panel.
12. Connect the air inlet and outlet tubing to the air pump. See Figure 9-15. The conical end of the check valve points in the direction of the air flow.
13. Replace the air pump access panel.
14. Connect the sample pump tubing to the pump. Connect the reagent and air injection tubing. Connect the air inlet tubing to the barbed fitting at the bottom of the enclosure.

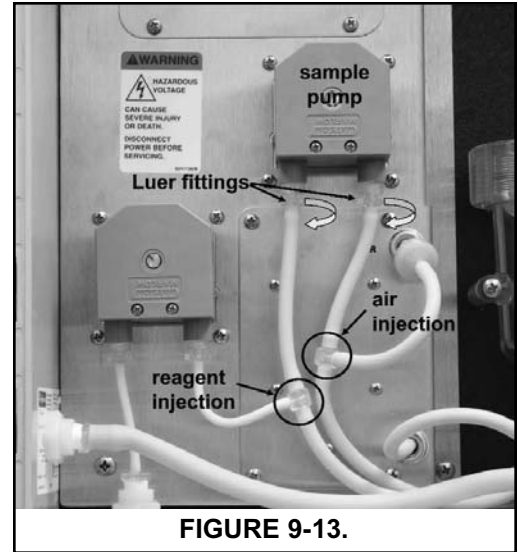
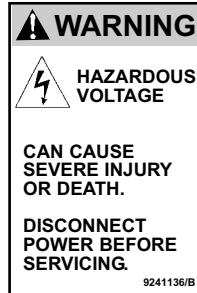

**FIGURE 9-13.**

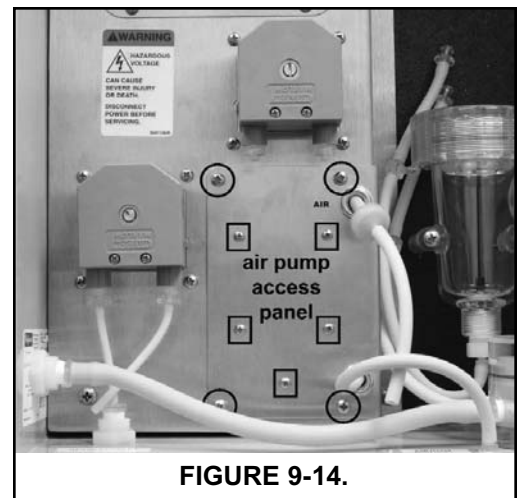

**FIGURE 9-14.**

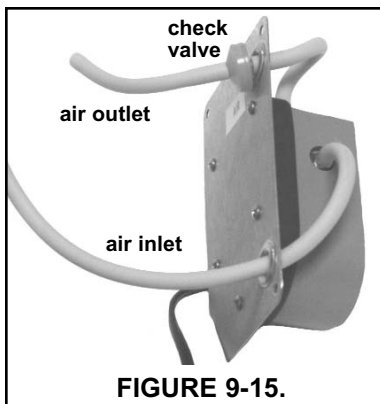

**FIGURE 9-15.**

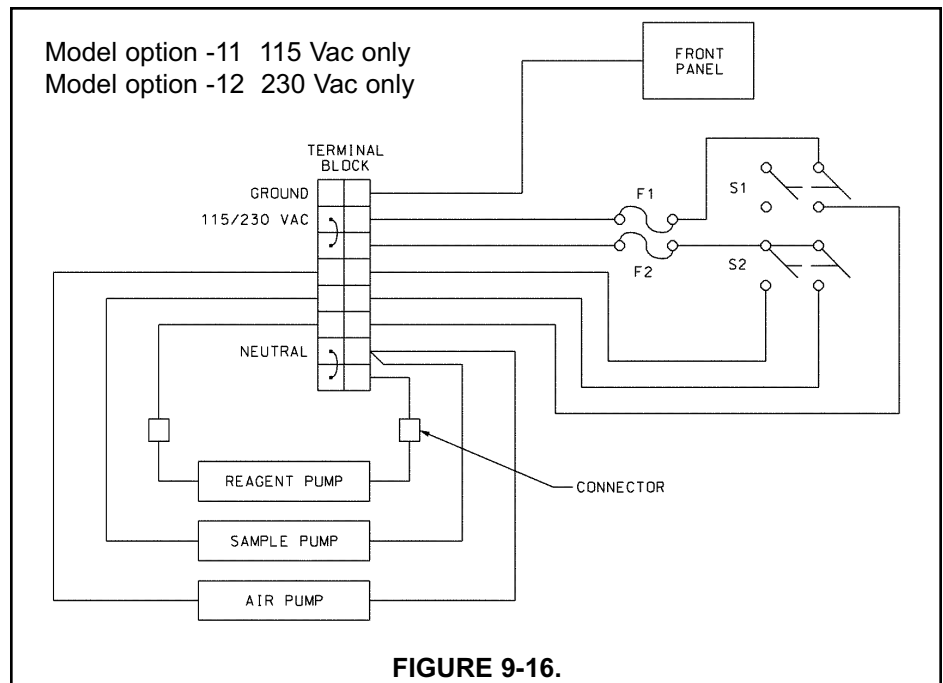

**FIGURE 9-16.**

### 9.3.5 Replacing the air pump diaphragm and check valves.

1. Disconnect power to the analyzer.
2. Refer to Figure 9-13. Disconnect the reagent and air injection tubes. Disconnect the suction and discharge tubing by turning the Luer fitting in the direction shown in the figure. Disconnect the air pump inlet tubing from the barbed fitting in the bottom of the enclosure.
3. Remove the four screws (circled in Figure 9-14) holding the air pump access panel. Pull out the pump and panel.
4. Disconnect the air inlet and outlet tubing from the air pump. See Figure 9-15.
5. Remove the five screws (surrounded by squares in Figure 9-14) holding the air pump to the access panel.
6. Pull the rubber base off the pump.
7. Using needle nose pliers, remove the air inlet fitting from the side of the air pump. See Figure 9-17.
8. Slide the pump assembly out of the air pump body. See Figure 9-18.
9. Following instructions on the package (PN 9160518), replace the diaphragm and check valves.
10. Slide the pump assembly back into the pump body and replace the barbed inlet fitting.
11. Replace the rubber base and screw the pump access panel back onto the air pump.
12. Connect the air inlet and outlet tubing to the air pump. See Figure 9-15. The conical end of the check valve points in the direction of the air flow.
13. Replace the air pump access panel.
14. Connect the sample pump tubing to the pump. Connect the reagent and air injection tubing. Connect the air inlet tubing to the barbed fitting at the bottom of the enclosure.

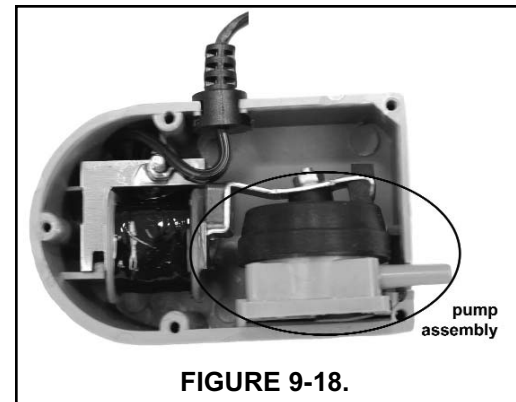
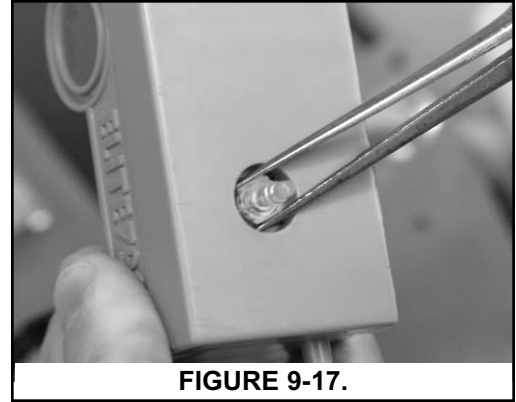
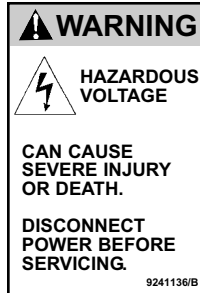

**TABLE 9-4. Replacement Parts and Reagent for Sample Conditioning System**

<b>PN</b>	<b>Description</b>
24134-00	Air pump, 115 Vac, 60 Hz
24134-01	Air pump, 230 Vac, 50 Hz
9160578	Air pump repair kit
9322052	Check valve for air injection line
24153-00	Carboy for reagent, 5 gal/19 L, includes cap
9100204	Fuse, 0.25 A, 250 V, 3AG, slow blow for option -11 (115 Vac)
9100132	Fuse, 0.125 A, 250 V, 3AG, slow blow for option -12 (230 Vac)
9380094	Reagent pump, 115 Vac, 50/60 Hz
9380095	Reagent pump, 230 Vac, 50/60 Hz
9380091	Reagent pump replacement tubing
24151-00	Reagent tubing replacement kit (see Section 9.3.2)
24135-00	Reagent uptake tubing, 6 ft (1.8 m), includes weight
9380090	Sample pump, 115 Vac, 50/60 Hz
9380093	Sample pump, 230 Vac, 50/60 Hz
9380092	Sample pump replacement tubing
24152-00	Sample tubing replacement kit (see Section 9.3.2)

<b>PN</b>	<b>Description</b>
24165-00	Acetic acid, 2 x 2.5 gal (9.5 L) bottles/case, with 25 g potassium iodide
24165-01	Acetic acid, 2 x 2.5 gal (9.5 L) bottles/case, with 50 g potassium iodide
24164-00	Potassium iodide, 25 g, sufficient for 5 gallons (19 L) of vinegar (for 0-5 ppm total chlorine)
24164-01	Potassium iodide, 50 g, sufficient for 5 gallons (19 L) of vinegar (for 0-10 ppm total chlorine)

## SECTION 10. TROUBLESHOOTING

### 10.1 OVERVIEW

The Solu Comp II continuously monitors itself and the sensor for faults. When the analyzer detects a fault, the word *fault* appears in the display alternately with the measurement. If alarm 3 was configured as a fault alarm, the alarm relay will energize. The outputs do not change during a fault condition. They continue to reflect the measured chlorine or temperature. **Press to display the fault codes.**

A large number of information screens are available to aid troubleshooting. The most useful of these are raw sensor current and sensitivity and zero current at last calibration. To view the information screens, go to the main display and press the key.

### 10.2 TROUBLESHOOTING USING FAULT CODES

Fault Code	Explanation	See Section
S1 Out of Range	Sensor current exceeds 210 $\mu$ A (chlorine only)	10.2.1
TC1 Open	RTD is open	10.2.2
TC1 Shorted	RTD is shorted	10.2.2
S1 Sense Line Open	RTD sense line is open	10.2.3
EEPROM Failure	EEPROM failure	10.2.4

#### 10.2.1 Sensor Current Exceeds 210 $\mu$ A

Excessive sensor current implies that the sensor is miswired or the membrane is torn. It can also mean that the sensor has failed.

#### 10.2.2 RTD is Open or Shorted.

There is an open or short in the sensor RTD or wiring.

- A. If sensor is being installed for the first time, check the wiring connections. See Section 4.3.
- B. Disconnect the sensor from the analyzer and measure the resistance between the RTD lead wires. See the sensor manual to identify the RTD leads. If there is an open or short circuit, replace the sensor.
- C. If there is no open or short, check the analyzer. See Section 10.5

#### 10.2.3 RTD Sense Line is Open.

The Solu Comp II measures temperature using a three-wire RTD. See Figure 10-3. The in and return leads connect the RTD to the measuring circuit in the analyzer. A third wire, called the sense line, is connected to the return line. The sense line allows the analyzer to correct for the resistance of the in and return leads and to correct for changes in lead wire resistance caused by changes in ambient temperature.

- A. Verify that all wiring connections are secure.
- B. The analyzer can be operated with the sense line open. The measurement will be less accurate because the analyzer can no longer correct for lead wire resistance and for changes in lead wire resistance with ambient temperature. However, if the sensor is to be used at approximately constant temperature, the lead wire resistance error can be eliminated by calibrating the sensor at the measurement temperature. Errors caused by changes in lead wire resistance with changes in ambient temperature cannot be eliminated. To make the error message disappear, connect the RTD sense and return terminals with a jumper.

#### 10.2.4 EEPROM Failure.

EEPROM failure means the analyzer is unable to store data in the non-volatile memory. Thus, if power is lost then restored, all configurations and calibrations will be lost. Call the factory for assistance. The analyzer will probably need to be replaced.

**10.3 TROUBLESHOOTING WHEN NO ERROR MESSAGE IS SHOWING**

<b>Problem</b>	<b>See Section</b>
Zero current was accepted, but the current is outside the range -10 to 50 nA	10.3.1
Error or warning message appears while zeroing the sensor (zero current is too high)	10.3.1
Zero current is unstable	10.3.2
Sensor can be calibrated, but current is low	10.3.3
Process readings are erratic or wander	10.3.4
Readings drift	10.3.5
Readings are too high	10.3.6
Readings are too low	10.3.3
Calibration temperature more than 3°C different from standard thermometer	10.3.7
Current output is too low	10.3.8
Alarm relays do not operate when setpoint is exceeded or do not release when reading is below setpoint	10.3.9
Display is unreadable — too faint or all pixels dark	10.3.10

**10.3.1 Zero current is too high**

- A. Is the sensor properly wired to the analyzer? See Section 4.3.
- B. Is the zero solution chlorine free? Take a sample of the zero solution and test it for total chlorine. The concentration should be less than 0.05 ppm. Avoid using tap water for zeroing the sensor. Even though the tap water contains no iodine, chlorine oxidants present in the tap water may produce a sensor current as high as 100 nA.
- C. Has adequate time been allowed for the sensor to reach a minimum stable zero current? It may take several hours, sometimes as long as overnight, for a new sensor to stabilize.
- D. Is the sensor fill solution fresh? An old, discolored fill solution may produce a high zero current.
- E. Is the membrane damaged? Inspect the membrane and replace it if necessary.

**10.3.2 Zero current is unstable**

- A. Is the sensor properly wired to the analyzer? See Section 4.3. Verify that all connections are tight.
- B. Readings can be erratic when a new sensor is first placed in service. Readings usually stabilize over about an hour.
- C. Is the space between the membrane and cathode filled with electrolyte solution and is the flow path between the electrolyte reservoir and membrane clear? Often the flow of electrolyte can be started by simply holding the sensor with the membrane end pointing down and sharply shaking the sensor a few times as though shaking down a clinical thermometer.

If shaking does not work, try clearing the holes around the cathode stem. Hold the sensor with the membrane end pointing up. Unscrew the membrane retainer and remove the membrane assembly. Use the end of a straightened paper clip to clear the holes at the base of the cathode stem.

Verify the sensor is filled with electrolyte solution. Refer to Section 9.2.

**10.3.3 Sensitivity is low or readings are low**

- A. Does the reagent carboy contain reagent? Is the reagent uptake tubing below the level of the reagent? Has potassium iodide been added to the acetic acid (vinegar) reagent?
- B. Is there adequate flow to the overflow sampler? Excess sample should be flowing down the inside tube of the flow controller.
- C. Does the reagent contain the correct amount of potassium iodide? See the table.

Expected range, ppm as Cl <sub>2</sub>	Amount of KI needed per 5 gallons of vinegar	Part number
0 – 5 ppm	25 grams	24164-00
0 – 10 ppm	50 grams	24164-01
0 – 20 ppm	2 x 50 grams	24164-01

- D. Was the comparison or calibration sample tested as soon as it was taken? Chlorine solutions can be unstable. Test the sample immediately after collecting it. Avoid exposing the sample to sunlight.
- E. Is the membrane fouled or coated? A dirty membrane inhibits diffusion of iodine through the membrane, reducing sensor current. Clean the membrane by rinsing it with a stream of water from a wash bottle. Wipe gently with a soft tissue.
- F. Are the reagent and sample pumps running? If a pump is not running, check the fuse and replace it if necessary. See Table 9-4 for part numbers. If the fuse is okay, replace the pump.
- G. Are all tube fittings tight? Pay particular attention to the luer fittings that connect the tubing to the pumps.
- H. Does the pump tubing element need replacing? Remove the tubing from the pump and inspect it. If the tubing appears permanently pinched or deformed, replace the tubing. Refer to Section 9.3.4 for instructions on how to remove and replace the tubing elements. The expected life of a tubing element is about one year.
- I. Is the sample flow to the sensor about 11 mL/min? If the sample flow is too low, the total chlorine reading will be low. If the flow is too high, the ratio between the sample flow and reagent flow will be too high, and there might be insufficient reagent to properly react with the total chlorine in the sample. To check sample flow...
1. Turn off the reagent and sample pumps.
  2. Disconnect the luer fitting on the discharge of the sample pump. See **A** in Figure 10-1.
  3. Hold a small beaker under the discharge port.
  4. Start the sample pump and collect sample for two minutes.
  5. Measure the volume of sample collected in the beaker. After two minutes, the volume should be about 22 mL.
- J. Is the reagent flow about 0.2 mL/min? If the reagent flow is too low, there might be insufficient acetic acid to lower the sample pH and insufficient potassium iodide to react with total chlorine in the sample. To check reagent flow...
1. Turn off the reagent and sample pumps.
  2. Disconnect the reagent tubing at the injection tee. See **B** in Figure 10-1.
  3. Place the end of the tubing in a 5 mL graduated cylinder.
  4. Start the reagent pump and collect reagent for ten minutes.
  5. Note the volume of reagent collected in the graduated cylinder. After ten minutes the volume should be about 2 mL.

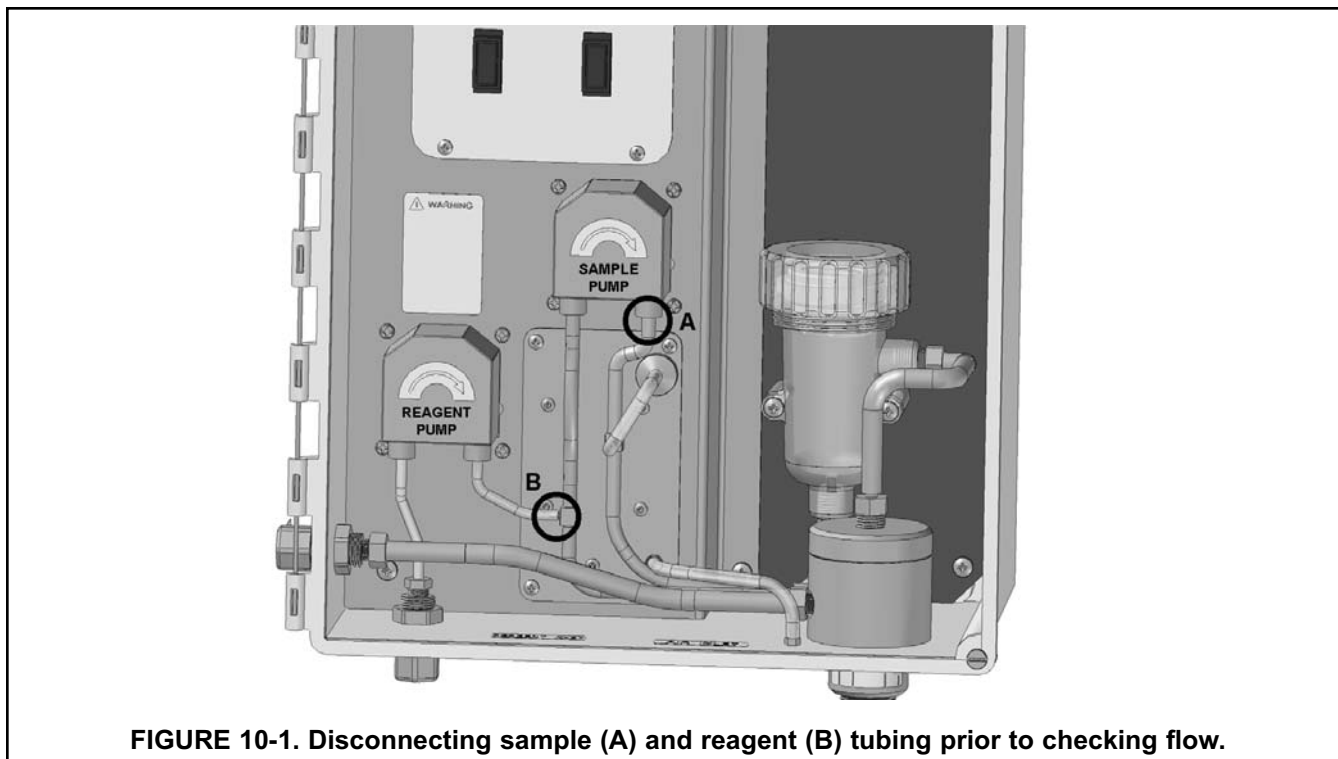

**FIGURE 10-1. Disconnecting sample (A) and reagent (B) tubing prior to checking flow.**

#### 10.3.4 Process readings are erratic or wander

- A. Is the sensor properly wired to the analyzer? See Section 4.3. Verify that all connections are tight.
- B. Readings can be erratic when a new sensor is first placed in service. Readings usually stabilize over about an hour.
- C. Is the air pump working? There should be a vigorous stream of bubbles in the flow cell. The bubbles help mix the sample and keep carbon dioxide bubbles off the membrane. Carbon dioxide forms when bicarbonate alkalinity in the sample reacts with acetic acid. The bubbles accumulate on the membrane and eventually break away, causing total chlorine reading to wander.
- D. Is the membrane damaged or loose? Replace the membrane if necessary.
- D. Is the space between the membrane and cathode filled with electrolyte solution and is the flow path between the electrolyte reservoir and membrane clear? Refer to Section 10.3.2C for more information.

#### 10.3.5 Readings drift

- A. Is the sample temperature changing? Membrane permeability is a function of temperature. The time constant for the 499ACL-01 sensor is about five minutes. Therefore the reading may drift for a while after a sudden temperature change.
- B. Is the membrane clean? For the sensor to work properly, iodine must diffuse freely through the membrane. A coating on the membrane will interfere with the passage of iodine, resulting in a gradual downward drift in readings. The coating will also slow the response on the sensor to step changes. Clean the membrane by rinsing it with a stream of water from a wash bottle. Wipe the membrane with a soft tissue.
- C. Is the sensor new or has it recently been serviced? New or rebuilt sensors may require several hours to stabilize.
- D. Is the flow of sample past the sensor about 11 mL/min? See Section 10.3.3D for more information.
- E. Is the reagent flow about 0.2 mL/min? See Section 10.3.3E for more information.

**10.3.6 Readings are too high**

- A. Is the sample conditioning reagent clear and colorless? If the reagent is pale yellow, results will be high. The pale yellow color is caused by iodine, which comes from the reaction between atmospheric oxygen and potassium iodide. The reaction is catalyzed by sunlight. The purpose of the blue carboy is to protect the reagent from sunlight.
- B. Is the sensor fill solution fresh? An old, discolored fill solution may produce a high reading.

**10.3.7 Temperature measured by standard thermometer was more than 3°C different from analyzer.**

- A. Is the standard thermometer, RTD, or thermistor accurate? General purpose liquid-in-glass thermometers, particularly ones that have been mistreated, can have surprisingly large errors.
- B. Is the temperature element in the sensor completely submerged in the liquid?
- C. Is the standard temperature sensor submerged to the correct level?

**10.3.8 Current Output Too Low.**

Load resistance is too high. Maximum load is 600 Ω.

**10.3.9 Alarm Relays Do Not Work**

- A. Verify the relays are properly wired.
- B. Verify that deadband is correctly set. See Section 7.4.

**10.3.10 Display is Unreadable.**

While holding down the MENU key, press ▲ or ▼ until the display has the correct contrast.

**10.4 SIMULATING INPUTS**

To check the performance of the analyzer, use a decade box and battery to simulate the current from the sensor. The battery, which opposes the polarizing voltage, is necessary to ensure that the sensor current has the correct sign.

- A. Disconnect the anode and cathode leads from terminals 1 and 2 on TB3 and connect a decade box and battery as shown in Figure 10-2. It is not necessary to disconnect the RTD leads.
- B. Set the decade box to the resistance shown below.

Polarizing Voltage	Resistance	Expected Current
200 mV	2.8 MΩ	500 nA

- C. Note the sensor current. It should be close to the value in the table. The actual value depends on the voltage of the battery. To view the sensor current, go to the main display and press ▼ until the sensor current is displayed.
- D. Change the decade box resistance and verify that the correct current is shown. Calculate current from the equation:

$$\text{current (nA)} = \frac{V_{\text{battery}} - V_{\text{polarizing (mV)}}}{\text{resistance (M}\Omega\text{)}}$$

The voltage of a fresh 1.5 volt battery is about 1.6 volt (1600 mV).

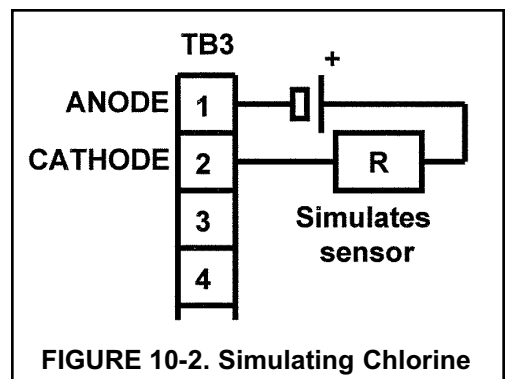

## 10.5 SIMULATING TEMPERATURE

### 10.5.1 General.

The Solu Comp II accepts either a Pt100 RTD (for pH and chlorine sensors). The Pt100 RTD is in a three-wire configuration. See Figure 10-3.

### 10.5.2 Simulating temperature

To simulate the temperature input, wire a decade box to the analyzer or junction box as shown in Figure 10-4.

To check the accuracy of the temperature measurement, set the resistor simulating the RTD to the values indicated in the table and note the temperature readings. The measured temperature might not agree with the value in the table. During sensor calibration an offset might have been applied to make the measured temperature agree with a standard thermometer. The offset is also applied to the simulated resistance. The Solu Comp II is measuring temperature correctly if the difference between measured temperatures equals the difference between the values in the table to within  $\pm 0.1^\circ\text{C}$ .

For example, start with a simulated resistance of  $103.9\ \Omega$ , which corresponds to  $10.0^\circ\text{C}$ . Assume the offset from the sensor calibration was  $-0.3\ \Omega$ . Because of the offset, the analyzer calculates temperature using  $103.6\ \Omega$ . The result is  $9.2^\circ\text{C}$ . Now change the resistance to  $107.8\ \Omega$ , which corresponds to  $20.0^\circ\text{C}$ . The analyzer uses  $107.5\ \Omega$  to calculate the temperature, so the display reads  $19.2^\circ\text{C}$ . Because the difference between the displayed temperatures ( $10.0^\circ\text{C}$ ) is the same as the difference between the simulated temperatures, the analyzer is working correctly.

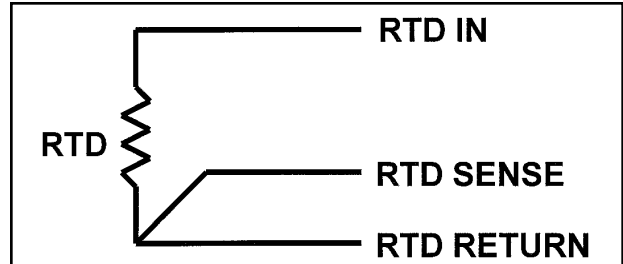

FIGURE 10-3. Three-Wire RTD Configuration.

Although only two wires are required to connect the RTD to the analyzer, using a third (and sometimes fourth) wire allows the analyzer to correct for the resistance of the lead wires and for changes in the lead wire resistance with temperature.

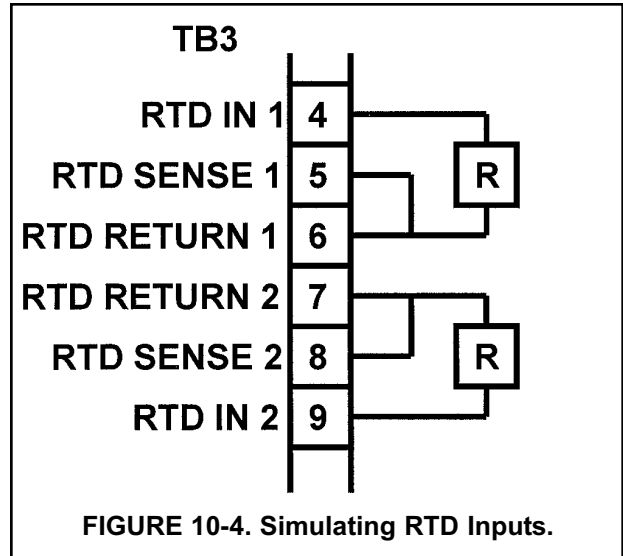

FIGURE 10-4. Simulating RTD Inputs.

Temp. ( $^\circ\text{C}$ )	Pt 100 ( $\Omega$ )
0	100.0
10	103.9
20	107.8
25	109.7
30	111.7
40	115.5
50	119.4
60	123.2
70	127.1
80	130.9
85	132.8
90	134.7
100	138.5

## SECTION 11. RETURN OF MATERIAL

- 11.1 GENERAL**
- 11.2 WARRANTY REPAIR**
- 11.3 NON-WARRANTY REPAIR**

### 11.1 GENERAL.

To expedite the repair and return of instruments, proper communication between the customer and the factory is important. Before returning a product for repair, call 1-949-757-8500 for a Return Materials Authorization (RMA) number.

### 11.2 WARRANTY REPAIR.

The following is the procedure for returning instruments still under warranty:

1. Call Rosemount Analytical for authorization.
2. To verify warranty, supply the factory sales order number or the original purchase order number. In the case of individual parts or sub-assemblies, the serial number on the unit must be supplied.
3. Carefully package the materials and enclose your "Letter of Transmittal" (see Warranty). If possible, pack the materials in the same manner as they were received.
4. Send the package prepaid to:

Emerson Process Management, Liquid Division  
Liquid Division  
2400 Barranca Parkway  
Irvine, CA 92606

Attn: Factory Repair

RMA No. \_\_\_\_\_

Mark the package: Returned for Repair

Model No. \_\_\_\_\_

### 11.3 NON-WARRANTY REPAIR.

The following is the procedure for returning for repair instruments that are no longer under warranty:

1. Call Rosemount Analytical for authorization.
2. Supply the purchase order number, and make sure to provide the name and telephone number of the individual to be contacted should additional information be needed.
3. Do Steps 3 and 4 of Section 11.2.

#### NOTE

Consult the factory for additional information regarding service or repair.

## WARRANTY

Seller warrants that the firmware will execute the programming instructions provided by Seller, and that the Goods manufactured or Services provided by Seller will be free from defects in materials or workmanship under normal use and care until the expiration of the applicable warranty period. Goods are warranted for twelve (12) months from the date of initial installation or eighteen (18) months from the date of shipment by Seller, whichever period expires first. **Consumables, such as glass electrodes, membranes, liquid junctions, electrolyte, o-rings, catalytic beads, etc., and Services are warranted for a period of 90 days from the date of shipment or provision.**

Products purchased by Seller from a third party for resale to Buyer ("Resale Products") shall carry only the warranty extended by the original manufacturer. Buyer agrees that Seller has no liability for Resale Products beyond making a reasonable commercial effort to arrange for procurement and shipping of the Resale Products.

If Buyer discovers any warranty defects and notifies Seller thereof in writing during the applicable warranty period, Seller shall, at its option, promptly correct any errors that are found by Seller in the firmware or Services, or repair or replace F.O.B. point of manufacture that portion of the Goods or firmware found by Seller to be defective, or refund the purchase price of the defective portion of the Goods/Services.

All replacements or repairs necessitated by inadequate maintenance, normal wear and usage, unsuitable power sources, unsuitable environmental conditions, accident, misuse, improper installation, modification, repair, storage or handling, or any other cause not the fault of Seller are not covered by this limited warranty, and shall be at Buyer's expense. Seller shall not be obligated to pay any costs or charges incurred by Buyer or any other party except as may be agreed upon in writing in advance by an authorized Seller representative. All costs of dismantling, reinstallation and freight and the time and expenses of Seller's personnel for site travel and diagnosis under this warranty clause shall be borne by Buyer unless accepted in writing by Seller.

Goods repaired and parts replaced during the warranty period shall be in warranty for the remainder of the original warranty period or ninety (90) days, whichever is longer. This limited warranty is the only warranty made by Seller and can be amended only in a writing signed by an authorized representative of Seller. Except as otherwise expressly provided in the Agreement, THERE ARE NO REPRESENTATIONS OR WARRANTIES OF ANY KIND, EXPRESS OR IMPLIED, AS TO MERCHANTABILITY, FITNESS FOR PARTICULAR PURPOSE, OR ANY OTHER MATTER WITH RESPECT TO ANY OF THE GOODS OR SERVICES.

## RETURN OF MATERIAL

Material returned for repair, whether in or out of warranty, should be shipped prepaid to:

**Emerson Process Management  
Liquid Division  
2400 Barranca Parkway  
Irvine, CA 92606**

The shipping container should be marked:

Return for Repair

Model \_\_\_\_\_

The returned material should be accompanied by a letter of transmittal which should include the following information (make a copy of the "Return of Materials Request" found on the last page of the Manual and provide the following thereon):

1. Location type of service, and length of time of service of the device.
2. Description of the faulty operation of the device and the circumstances of the failure.
3. Name and telephone number of the person to contact if there are questions about the returned material.
4. Statement as to whether warranty or non-warranty service is requested.
5. Complete shipping instructions for return of the material.

Adherence to these procedures will expedite handling of the returned material and will prevent unnecessary additional charges for inspection and testing to determine the problem with the device.

If the material is returned for out-of-warranty repairs, a purchase order for repairs should be enclosed.



*The right people,  
the right answers,  
right now.*

ON-LINE ORDERING NOW AVAILABLE ON OUR WEB SITE  
<http://www.raihome.com>

*Specifications subject to change without notice.*

**Pollardwater** dot com

Phone 800-437-1146  
Fax 425-861-7235  
[info@pollardwater.com](mailto:info@pollardwater.com)

**West Coast Branch**  
17515 NE 67<sup>th</sup> Ct  
Redmond, WA 98052

**East Coast Branch**  
200 Atlantic Ave  
New Hyde Park, NY 11040

Credit Cards for U.S. Purchases Only.

