

# DL75

## DATA LOGGER SYSTEM INSTRUCTIONS



DL75 DATALOGGER SYSTEM  
INSTRUCTIONS

# SeaMetrics

19026 72ND AVENUE SOUTH  
KENT, WA 98032 USA  
(P) 253.872.0284 (F) 253.872.0285  
WWW.SEAMETRICS.COM  
1.800.975.8153

## GENERAL INFORMATION

The DL75 is a battery-powered flow logger that can be used with any SeaMetrics flowmeter, and many others with pulsers, such as a propeller meter with a reed switch. It can store pulses for weeks or months, depending on the user-set frequency of reading. An indicator light on the unit flashes to indicate that it is functioning, and another indicator flashes when the battery is low.

The housing of the DL75 connects directly to SeaMetrics IP, TX, or WT flow meters. It can be ordered with a wall mount housing for other applications.

Retrieval of data from the unit is by means of a low-cost handheld computer loaded with special software. The handheld can also be used to instantly read flow rate and total, and all of the normal handheld functions (address, calendar, note storage) are available as well. One handheld can be used to retrieve data from up to 16 loggers. After the data is downloaded into the handheld, hot-syncing transfers the data into the desktop computer for graphing and other processing.

When a DL75 Data Logger is placed into operation, it is easily set up using the handheld. This involves assigning an identifier to the logger, choosing units, entering the meter k-factor, specifying the frequency of reading, and choosing stop or overwrite when the logger is full.



## SPECIFICATIONS

POWER		
• 3.6 VDC lithium battery (included)		
BATTERY LIFE		
• 3 years		
VOLUME UNITS		
• mL, liter, gallon, cubic foot, cubic meter, million gallons, acre feet		
TIME UNITS		
• Seconds, minutes, hours, days		
CAPACITY @ (SAMPLE)	DAYS	SECS
	• 11	• 15
	• 22	• 30
	• 60	• 60
	• 90	• 120
	• 180	• 240
INDICATORS		
• Replace battery, power/flow (dual rate blinking)		
MEMORY WRAPAROUND		
• Selectable options		
CLOCK ACCURACY		
• 10 minutes/month (.02%)		

## DIMENSIONAL DRAWINGS

### WALL MOUNT

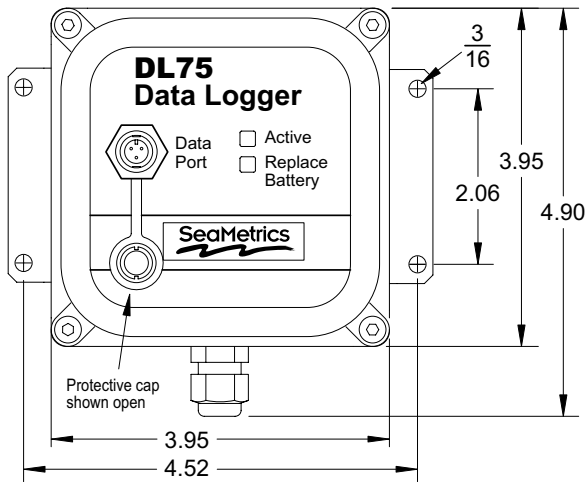

### SENSOR MOUNT

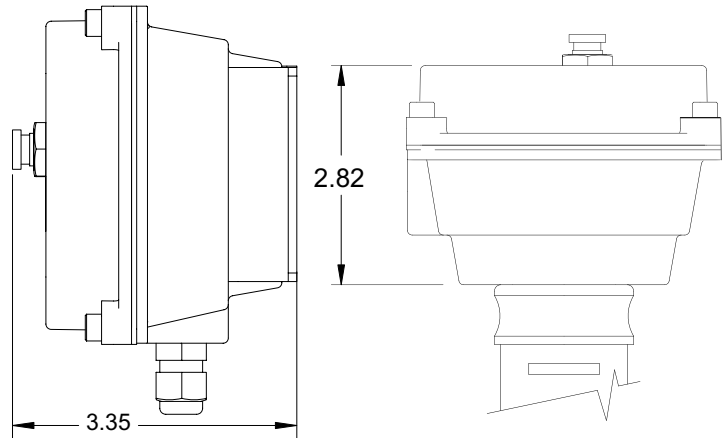

### DL75 FEATURES OVERVIEW

Tighten screws evenly after making connections, to ensure a good seal. Gasket should be visibly compressed all around.

Data port connector with waterproof cap. Connects to data collection cable (cap shown open). Replace cap after removing cable.

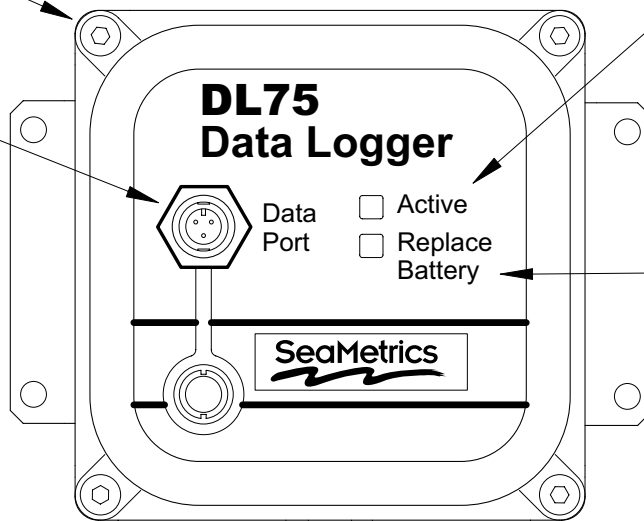

Signal LED  
 - Slow blink means functioning unit / no flow  
 - Fast blink means functioning unit / flow

If blinking, battery should be replaced within a few days. Dead battery will result in failure to log new data.

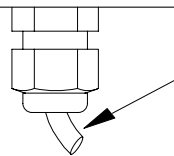

Cable to meter (wall mount only). Tighten strain relief firmly around cable to prevent leakage.

## DL75 INSTALLATION

### Mounting and Connections

There are two mounting configurations for a DL75, meter and wall. It can be factory ordered or field-installed in either configuration. The unit matches up to any SeaMetrics lower square housing. These come installed on any 100/200-Series IP or TX insertion meter, and can be added to any 80-Series flow sensor (requires MK10 mounting kit). Any DL75 can be field-converted to a wall mount using the MK20 wall mount kit.

To install a DL75 module to an existing meter, remove the four screws which hold on the blind cover with a 5/32" Allen wrench. After connecting the leads to their respective terminals, (see the "Connection" diagram) put the DL75 in place of the blind cover and tighten the screws evenly. The gasket on the DL75 should be compressed by the tightening.

### DL75 CONNECTION DIAGRAM

3.6 VDC Lithium C-cell. Normal life is three years. When battery light on the front of the logger begins to blink, remove and replace the battery as soon as possible. Logger data is non-volatile, and will be preserved during battery change.

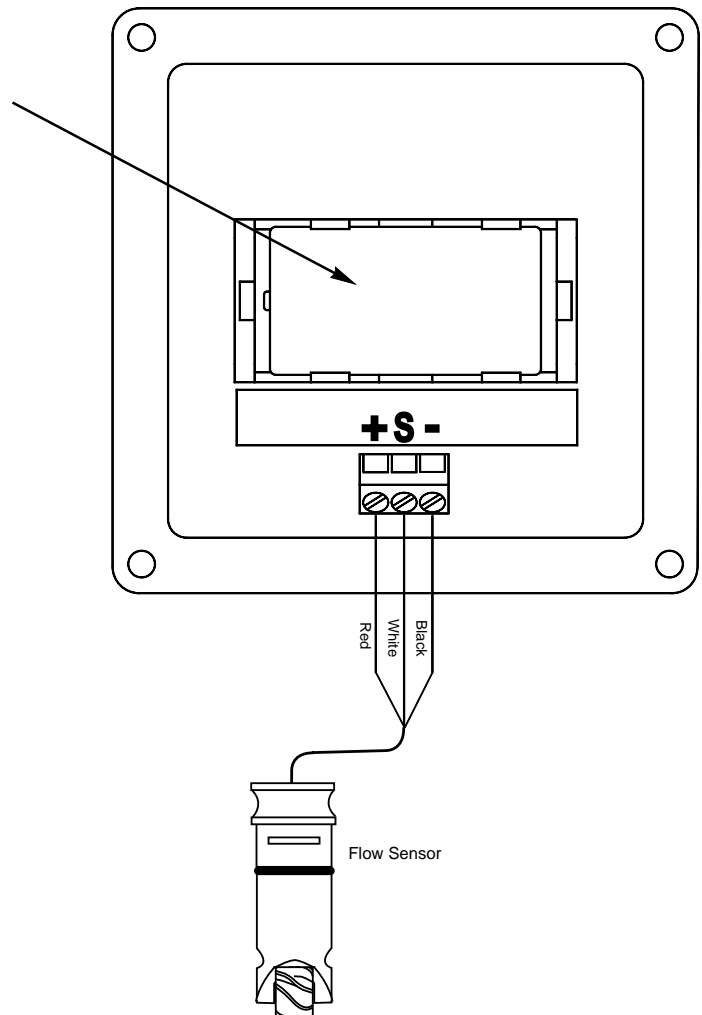

## DL75 INITIAL SETUP

A handheld computer is used for setup and data transport. It is necessary to load the handheld with its FlowRetriever (FRETRIEVE.PRC) software before setting up the DL75. This software is installed on your desktop computer during installation of FlowInspector software, and is loaded into your handheld during the next HotSync operation, causing the  icon to appear on its screen.

**Data Cable:** Pull the dust cap off of the Data Port on the DL75, and plug the round end of the data cable. Plug the rectangular end of the cable into the handheld.

**Buttons:** From the home menu on the handheld, tap the  icon marked "Flow Retr." Four buttons will appear. Tap "Initialize" to bring up "settings."



Tap "initialize"  
to bring up "settings"  
for initial setup



## SETTINGS

All of the following should be set before putting the logger into service.

**Start Date and Start Time:** These will be automatically set when you tap "Start New Session."

**K-factor:** This is the pulses per gallon which the meter produces. For a SeaMetrics meter, get the number from the meter fitting (80-Series) or the k-factor table in the instruction manual.

**Datalogger Number:** This is the identifier for the datalogger, which allows one handheld to service multiple loggers. Assign any number you choose, up to 6 digits.

**ID:** This is a name to help you identify the logger later, for example "Pump Station 3."

**Cycle:** Choose the frequency of recording (in seconds), from 15 to 240. Shorter times provide a smoother flow curve, but shorten the number of days until the logger memory is full.

**Stop when Full:** If this box is checked, the DL75 will stop reading when its memory is full. If the box is not checked, it will begin overwriting the oldest data when it is full, and that data will be lost.

**Start New Session:** Do not press this button unless you wish to erase all previous data and begin an entirely new session.

**OK:** This brings back the four main buttons.

When all of the settings have been made, disconnect the cable and replace the dust cap. The logger is now operational.

## DL75 SETUP & FIELD MONITORING



Tap "Rate/Total"  
to set the volume  
and time units.

### FLOW RATE AND TOTAL

Press this button to set the volume and time units.  
It can also be used to read the meter in real time.

Tap the desired volume unit (milliliters, liters, gallons, imperial gallons, cubic feet, cubic meters, million gallons, or acre feet) and then the desired time unit (seconds, minutes, hours, days). Rate and total will be displayed and recorded in these units.

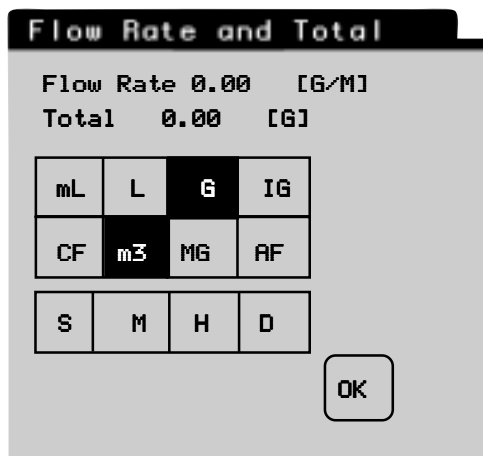

### STORAGE

This display shows the files which are being stored in the PDA. To delete a file, highlight and tap "delete."

File name format is:

Year, Month, Date, Logger number

Example: July 24, 2003 Logger #365

appears as: 030724365



## DL75 DATA RETRIEVAL

### DOWNLOAD FUNCTION



Tap "Download" to transfer data from the Data Logger to your handheld computer.

When the Download button is pressed, the upper part of the display reads "Downloading 0%." The percent rises, giving an indication of progress. Download and processing can take up to four minutes. A "Please wait" icon indicates that the download is complete, and processing has begun. As processing progresses, a graph of the flow rate for the period appears. The period to be graphed on the handheld's screen can be changed by using the "From" and "To" buttons and tapping on the appropriate dates.

When downloading is complete, press the "OK" button. The cable can now be disconnected and the data can be carried back to the desktop computer in the handheld.

Screen 1



If you press "YES," Screen 2 will appear with % increasing.

If you press "NO" you will return to the four button display.

Screen 2

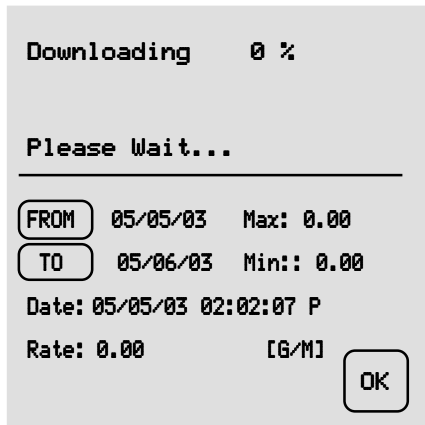

Screen 3

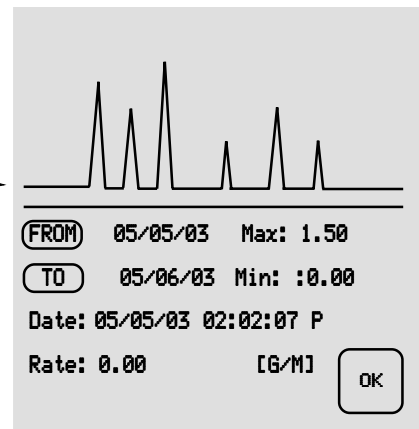

When data finishes downloading, the graph will automatically be drawn.

## DL75 TROUBLESHOOTING

Problem	Probable Cause	Try...
Handheld reads, "No connection," but "Active" light is <u>NOT</u> blinking.	<ul style="list-style-type: none"> <li>• DL75 is transmitting data. Wait two minutes before taking action.</li> <li>• Dead battery in DL75</li> </ul>	<ul style="list-style-type: none"> <li>• Wait for "Active" light to blink</li> <li>• Replace battery</li> </ul>
Handheld reads, "No connection," but "Active" light <u>IS</u> blinking.	<ul style="list-style-type: none"> <li>• Loose cable</li> <li>• Bad Cable</li> </ul>	<ul style="list-style-type: none"> <li>• Tighten cable</li> <li>• Replace Cable</li> </ul>
Flow rate incorrect	<ul style="list-style-type: none"> <li>• K-factor setting is incorrect</li> </ul>	<ul style="list-style-type: none"> <li>• Make sure K-factor in DL75 matches flow sensor</li> </ul>
No flow rate	<ul style="list-style-type: none"> <li>• Damaged flow sensor</li> <li>• Broken wire</li> </ul>	<ul style="list-style-type: none"> <li>• Spin flow sensor</li> <li>• Check for flow rate</li> </ul>



19026 72ND AVE SOUTH, KENT, WA 98032 USA  
(P) 253.872.0284 (F) 253.872.0285  
WWW.SEAMETRICS.COM 1.800.975.8153