



OWNER'S MANUAL

AccUView

UV Transmission Monitor

Pollardwater dot com

Phone 800-437-1146
Fax 425-861-7235
info@pollardwater.com

Catalog No. 24238 (8/06)
Rev. 2.3

West Coast Branch
17515 NE 67th Ct
Redmond, WA 98052

East Coast Branch
200 Atlantic Ave
New Hyde Park, NY 11040

DECLARATION OF CONFORMITY

Application of Council Directive
Standards to Which Conformity is Declared:

Product Safety - Tested and passed CE EN61010-1: 1990 + A1: 1992 (73/32 EEC)
- Tested and passed ETL (tested to UL3111-1), 1st Edition, 1994,
w/Bulletin June 5, 1996
- Tested and passed ETLc (tested to CSA C22.2#1010.1-92)

Immunity – Tested and passed EN61326: 1997+A1: 1998
Including:
IEC61000-4-2
IEC 61000-4-3
IEC 61000-4-4
IEC 61000-4-5
IEC 61000-4-6
IEC 61000-4-8
IEC 61000-4-11

Emissions - Tested and passed EN61326: 1997+A1: 1998
Including:
CISPR 11 Radiated Emissions Class B
CISPR 11 Conducted Emissions Class B
EN 61000-3-2
EN 61000-3-3

Manufacturer's Name: HF scientific, inc.

Manufacturer's Address: 3170 Metro Parkway, Fort Myers, Florida 33916-7597

Importer's Name:

Importer's Address:

Type of Equipment: Process Monitor

Model No: AccUView

I, the undersigned, hereby declare that the equipment specified above conforms to the above Directive and Standard

Place: Fort Myers, Florida USA

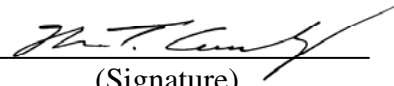
(Signature)

Rowan T. Connelly, General Manager

Table of Contents

Section	Page
Specifications.....	1
1.0 Overview.....	2
1.1 Unpacking and Inspection of the Instrument and Accessories	2
1.2 The Display	3
1.3 The Touch Pad	3
1.4 Vapor Purge	4
2.0 Safety	4
3.0 Installation and Commissioning	5
3.1 Mounting and Site Selection.....	5
3.2 Plumbing	6
3.2.1 Pressurized Systems.....	7
3.2.2 Drain Vent.....	7
3.3 Electrical Connections	7
3.3.1 Power	8
3.3.2 RS-485	8
3.3.3 Relays.....	8
3.3.4 4-20 mA	8
4.0 Operation	9
4.1 Warm-up	9
4.2 Routine Measurement	9
4.3 Security Access Feature.....	10
5.0 Instrument Calibration	11
5.1 100%T Calibration.....	11
5.2 100%T Calibration Error	12
6.0 Instrument Offset	13
6.1 Restoring Factory Settings.....	14
7.0 Instrument Configuration (CONFIG mode)	15
7.1 Selecting the Output (O/P)	15
7.2 Setting the 4-20 mA.....	15
7.3 Configuring the RS-485 Port	16
7.4 Configuring the Alarms	17
7.4.1 Alarm 1	17
7.4.2 Alarm 2	18
7.5 Offset Calibration.....	18
7.6 Enabling the Security Access.....	19

Table of Contents (continued)

Section		Page
	7.7	Extended Settings.....19
	7.8	Speed of Response19
	7.9	LCD Backlight Brightness.....20
	7.10	Ultrasonic Cleaning20
	7.11	RS-485 Parameter - Bits20
	7.12	RS-485 Parameter - Parity21
	7.13	RS-485 Parameter – Stop Bits21
	7.14	Lamp Duty Cycle.....21
	7.15	Desiccant Alarm.....22
	7.16	Saving Configuration Settings22
8.0		Additional Features and Options23
	8.1	Backlit LCD23
	8.2	Ultrasonic Cleaning23
	8.3	RS-485 Output23
	8.3.1	HF Online.....23
	8.3.2	Simple Communication24
	8.3.3	Modbus Communication.....24
	8.4	Flow Alarm24
	8.5	Remote Panel Meter.....24
9.0		Routine Maintenance25
	9.1	Cleaning the Flow Through Cuvette.....25
	9.2	Replacing or Installing the Desiccant Pouch25
	9.3	Replacing the Source Lamp26
10.0		Troubleshooting27
	10.1	AccUView Fault Detection.....27
	10.2	System Fail Message27
	10.3	Diagnostic Chart28
	10.4	Technical and Customer Assistance28
11.0		Accessories and Replacement Parts List29
12.0		Warranty30

Specifications

Measurement Range	0 – 100.0 %T
Reproducibility	± 0.1 %T
Resolution	0.1 % T
Accuracy	± 1.0 % T
Response Time	Adjustable 4 to 60 seconds
Path Length	22 mm(Readings corrected to 10 mm)
Display	Multi-Line Liquid Crystal Backlit Display
Alarms	Two Programmable, 120-240VAC 2A Form C Relay
Analog Output	Powered loop isolator 4-20 mA, 600 Ω drive
Communications Port	Optional bi-directional RS-485 with Modbus
Maximum Water Pressure	1380 kPa (200 psi.) with integral pressure regulator
Flow Rate	100 ml/min. – 1 liter/min. (.026-.26 Gal/min) with integral flow regulator
Operating Temperature	0°C – 50°C (32°F – 122°F)
Wetted Materials	Nylon, Quartz, Silicon, Polypropylene, Stainless Steel, CAB
Sample Temperature Range	0°C – 50°C (34°F – 122°F)
Power Supply	100– 240 VAC, 47 – 63 Hz, 80VA
Insulation Rating	Double Insulated, Pollution Degree 2, Overvoltage Category II
Environmental Conditions	Not recommended for outdoor use. Altitude up to 2000 meters Up to 95 % RH (non-condensing)
Enclosure Rating	IP 66 /NEMA 4X
Regulatory Compliance And Certifications	CE Approved, ETL listed to UL 3111-1 & ETL Certified to CSA 22.2 No. 1010-1-92
Shipping Weight	2.5 kg (5.5 lbs.)
Warranty	1 Year from date of shipment

1.0 Overview

The AccUView process transmission monitor allows for the UV transmission measurement of process water on-line.

A unique feature of the instrument is the ultrasonic cleaning. Refer to section 8.2 for more information.

1.1 Unpacking and Inspection of the Instrument and Accessories

The table below indicates the items in the monitor shipment.

Item	Quantity
AccUView Monitor c/w Field Terminal Box & Flow Through Assembly	1
Instruction Manual	1
Desiccant Pack	1
Quartz Cuvette with Ultrasonic Transducer (Single Pack)	2
100 % T Calibration Standard	1
Tubing Kit *	1

* Note - Tubing Kit includes:

- 1-shutoff clamp
 - 1-backpressure valve
 - 2-connecting tubings with fittings for flow through assembly
 - 1-drain vent screw (used in pressurized systems)
- Refer to Figure 4.

Remove the instrument from the packing carton. Carefully inspect all items to ensure that no visible damage has occurred during shipment. If the items received do not match the order, please immediately contact the local distributor or the HF scientific, inc. Customer Service department.

Note: The Quartz cuvette is shipped separate from the flow through unit. This cuvette must be installed on the flow through, prior to running water through the system.

1.2 The Display

Figure 1 illustrates all the items that can appear on the display. The upper row of the display (1) is used for reporting the % T levels and to provide user guidance in the customer setting routine. The lower row of the display (2) is used to communicate error messages and provide user guidance. All error messages will be added to a queue along with the units (%T). The display has two icons (3) that are used to indicate the use of access code and offset mode. In addition, mode arrows (4) are used to indicate the current instrument operating mode; AUTO (normal operation), CAL (calibration) and CONFIG (configuration).

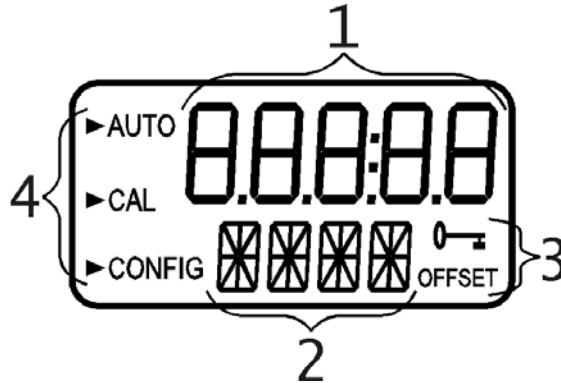

Figure 1 – Display used in the instrument.

All items used on the display are shown in this figure

1.3 The Touch Pad

Figure 2 illustrates the touch pad. The touch pad has four buttons: **MODE/EXIT**, \leftarrow , \uparrow , and \downarrow . The **MODE/EXIT** button is used to cycle between the three operational modes of the instrument: **CAL**, **CONFIG**, and **AUTO** (Measurement) mode. The \leftarrow button enters the option (or mode that is highlighted or chosen. The \uparrow and \downarrow buttons are used to change settings.

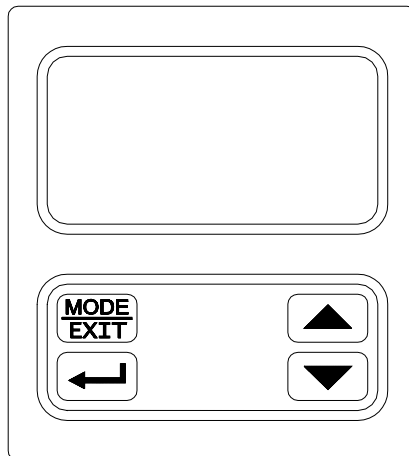

Figure 2: The AccUView touch pad.

1.4 Vapor Purge

The AccUView is equipped with a continuous vapor purge system. A replaceable desiccant pouch in the lower portion of the instrument dries the air. System heat is used to warm the air. A fan inside the instrument continuously circulates heated dry air around the optical well and the flow through cuvette. This feature eliminates the need for a dry purge line.

The AccUView monitors the replaceable desiccant pouch condition continuously. The LCD display will show **DESC** on the lower line in the event that the desiccant pouch needs replacement. Replacement desiccant pouches are available from HF scientific, inc. or the local representative (Part # 21555R). Refer to section [9.2 Replacing or Installing the Desiccant Pouch](#)

2.0 Safety

This manual contains basic instructions that must be followed during the commissioning, operation, care and maintenance of the instrument. The safety protection provided by this equipment may be impaired if it is commissioned and/or used in a manner not described in this manual. Consequently, all responsible personnel must read this manual prior to working with this instrument.

In certain instances **Notes**, or helpful hints, have been highlighted to give further clarification to the instructions. Refer to the *Table of Contents* to easily find specific topics and to learn about unfamiliar terms.

3.0 Installation and Commissioning

Prior to use for the first time, the supplied desiccant pouch will need to be installed. Refer to section [9.2 Replacing or Installing the Desiccant Pouch](#).

3.1 Mounting & Site Selection

The instrument is designed for wall mounting. For ease of service there should be about 20 cm (8") free area above the instrument; this will ensure enough room for calibration and cuvette maintenance. Choose a location that is easily accessible for operation and service and ensure that the front display rests at eye level. The overall mounting dimensions of the instrument are shown in Figure 3. The recommended mounting screws are M6 (1/4") for the instrument enclosure and M4 (3/16") for the field terminal box. The AccUView is designed to have the field terminal box cradled under the sensor portion of the instrument. It is recommended that the field terminal box be mounted first, and then the rest of the instrument be mounted on top. The template included on the last page of this manual may be used to establish mounting-hole locations.

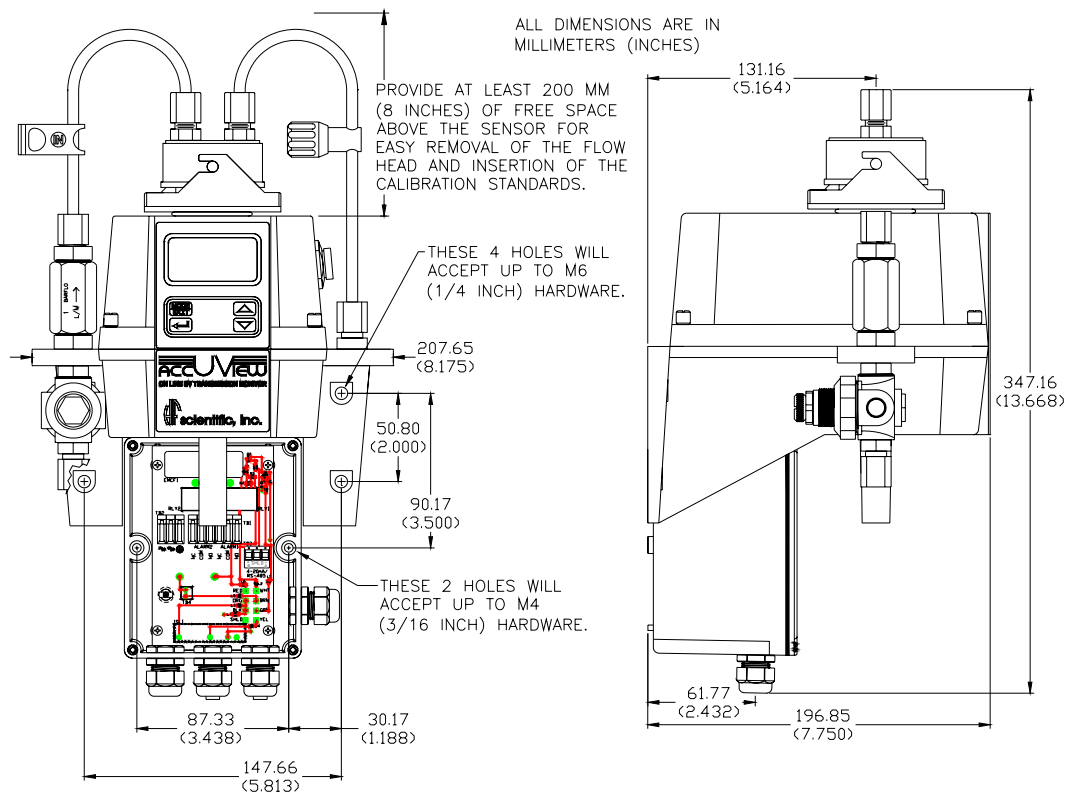

Figure 3: Overall Mounting Dimensions of the Instrument

It is critical that the instrument be mounted as close as possible to the sampling point to ensure a quick response time (within 2-3 meters (6-10 ft) of the sampling point).

3.2 Plumbing

The recommended plumbing for the instrument is shown in Figure 4. The instrument is designed to require very little head pressure to operate; around 6.9kPa (1 PSI). Flow requirements are 100ml/min. – 1 liter/min. (0.026-0.26Gal/min). The integral flow regulator will limit flow to around 1 liter/min. The pressure regulator will allow for a maximum pressure of 1380kPa (200 PSI.). The maximum allowable fluid temperature is 50°C (122°F).

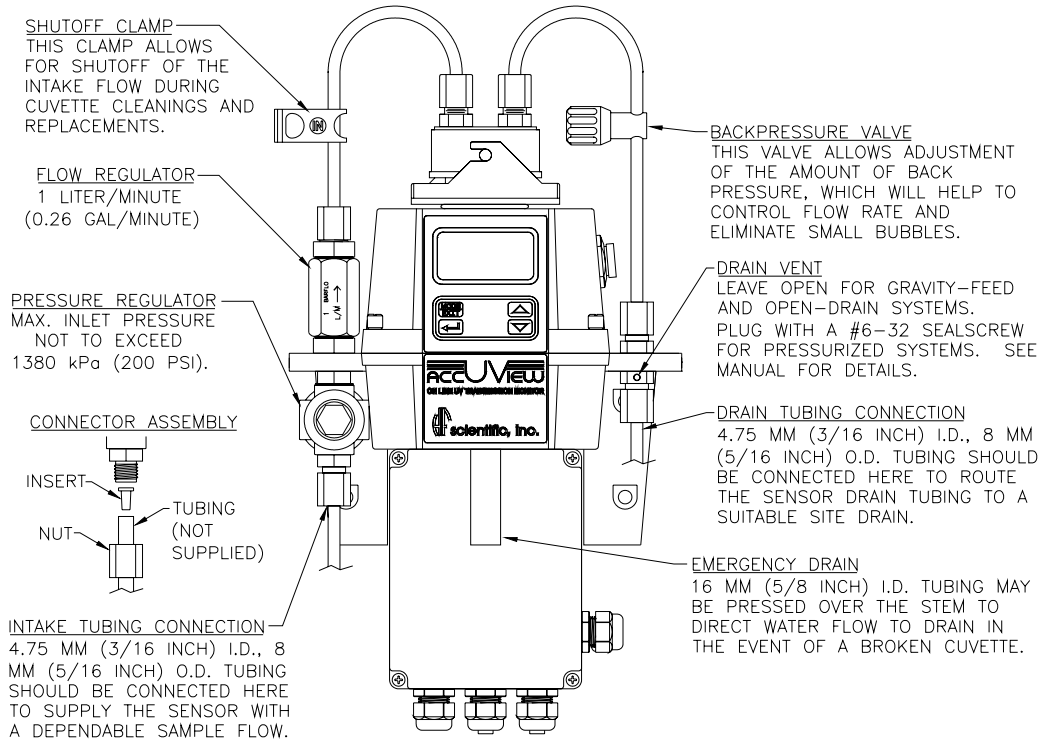

Figure 4: Recommended Plumbing for the Instrument

The instrument is equipped to be plumbed using 4.75 mm (3/16”) ID, 8 mm (5/16”) OD flexible tubing. Opaque tubing should be used if the tubing will be exposed to sunlight, to prevent algae growth.

In figure 4, there are two operator controlled flow adjustment devices shown. The one on the input side is a shutoff clamp used during cuvette maintenance. The other device, located on the output side of the flow cell, is a backpressure valve. Backpressure may be required to prevent air from coming out of solution, which may be observed as tiny air bubbles.

The instrument is equipped with an internal foot valve, which opens in case the flow through cuvette ruptures to prevent damage to the sensor. The stem of the emergency drain can be connected to a 16 mm (5/8”) tube (not supplied) to direct the flow of water to a convenient drain in the event of a cuvette breakage. Keep the length of this emergency drain to a minimum.

3.2.1 Pressurized Systems: A standard feature of the AccUView is a pressure regulator. The regulator is rated for use up to 1380 kPa (200 PSI) and will lower the pressure down to a pressure more suitable for use in the AccUView. If inlet pressures can exceed 325 kPa (47 PSI) use appropriate tubing to connect to the AccUView. The integral flow regulator will limit the flow to 1 liter per minute.

3.2.2 Drain Vent: The AccUView has been fitted with a drain vent in the “OUT” bulkhead fitting. This fitting allows for atmospheric equalization, thus helping to alleviate bubble formation in the cuvette. Refer to Figure 4.

Upon initial flow minor leakage may occur through the drain vent. This will subside once normal flow is established.

For some high pressure systems, where the vent hole continuously leaks, a 6:32 seal screw is provided which should be inserted into the vent hole and tightened.

3.3 Electrical Connections

All of the electrical connections to the instrument are made through the field terminal box, which should be located directly under the sensor portion of the instrument. The connections are labeled within the terminal box and are self-descriptive (see Figure 5). Please follow all local and government recommendations and methods for installation of electrical connections to and between the instrument and other peripheral devices.

Plugs are inserted into the alarm and 4-20mA/RS-485 cable bulkheads when shipped, to ensure a watertight seal. These plugs should be removed and discarded when cabling to either of these connections.

The power cable bulkhead will accept cable diameters from 5.8mm (.230 in.) up to 10 mm (.395 in.). All terminals are designed to accept wires in the range of 14-28 AWG. All wires should be stripped to a length of 6 mm (¼”). A strain relief strap is provided to reduce tension on the power terminals.

It is the user’s responsibility to assure that the watertight seal is maintained after the terminal box has been wired for operation. If any of the bulkheads are not tightened properly around a cable or plug, the ratings of the instrument will be jeopardized and there is a possibility of creating a shock hazard.

Note: Only qualified electricians should be allowed to perform the installation of the instrument as it involves a line voltage that could endanger life.

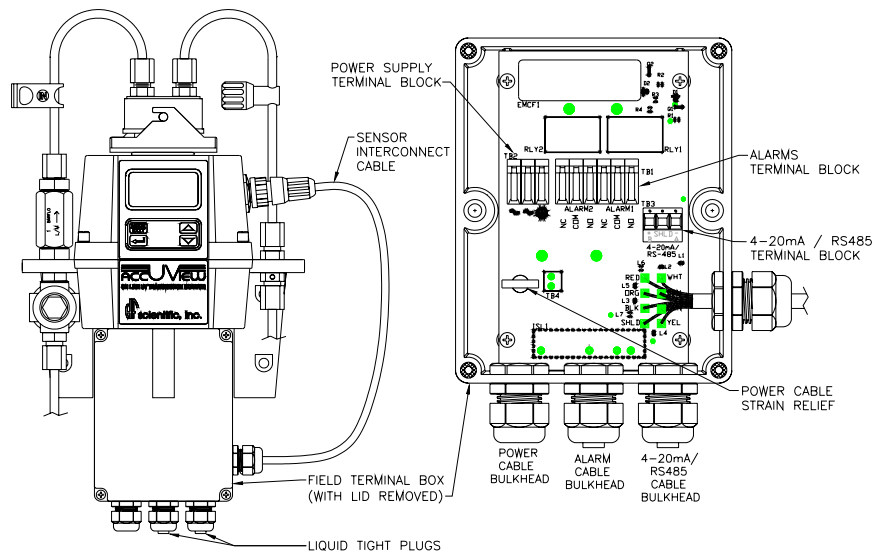

Figure 5: Electrical Connections for the Instrument

3.3.1 Power: The instrument is equipped with a 100-240 VAC, 47-63 Hz switching power supply; please verify that the line voltage falls within these specifications. It is recommended that a circuit breaker be placed prior to the power connection to allow for service. While making connections, refer to Figure 5. **The AccUView is not supplied with a power cord.**

3.3.2 RS-485(optional): The RS-485 Modbus or special protocol half-duplex (2-wire) digital interface operates with differential levels that are less susceptible to electrical interferences. This is why cable lengths up to 3000 ft can be implemented. The last device on each bus may require terminating with a 120-ohm resistor to eliminate signal reflection on the line. Do not run RS-485 cables in the same conduit as power.

To prevent damage to the instrument, ensure that power is disconnected prior to making connections. For ease of connecting, remove the plug in terminal block. Connections are labeled beneath this termination.

This factory installed option is available (HF catalog #19851A). Please note that adding this option deletes the standard isolation on the 4-20 mA output.

3.3.3 Relays: The Alarm 1 and Alarm 2 relays are mechanical relays rated at 240 VAC 2A. Please note that the relays are labeled NO (Normally Open), NC (Normally Closed) and C (Common). As these alarms are configured fail-safe, the normal condition is with power applied to the AccUView and in a non-alarm condition. Operation of these alarms is covered in section [7.4 Configuring the Alarms](#).

3.3.4 4-20 mA: The 4-20 mA output is driven by a 15 VDC power source and can drive recorder loads up to 600 ohms. Do not run 4-20 mA cables in the same conduit as power. Operation of this output is covered in section [7.2 Setting the 4-20 mA](#). The outputs are equipped standard with an installed loop powered isolator (500V isolation).

Ensure each instrument is not powered when connecting the 4-20 mA. To prevent damage to the instrument, ensure that power is disconnected prior to making connections. For ease of connecting, remove the plug in terminal block. Polarity of the connections is labeled beneath this termination.

4.0 Operation

This process monitor allows for the measurement of the transmission of process water on-line. Process water is usually reported in units of %T. Readings below 30 %T are outside the range of this instrument. Readings above 102 %T are indicated by a flashing display. Readings above 100 %T indicate that the current sample is better than the calibration water. Readings above 102 %T will cause an alarm condition to occur where both relays will change to the alarm condition and the 4-20 mA will change to 2 mA. Readings above 110 %T are not possible. All readings are path length corrected.

During normal operation, the instrument will have the arrow beside **AUTO**. The scale (% T) is displayed on the lower row of the display and the measured reading on the upper row of the display (see illustration below).

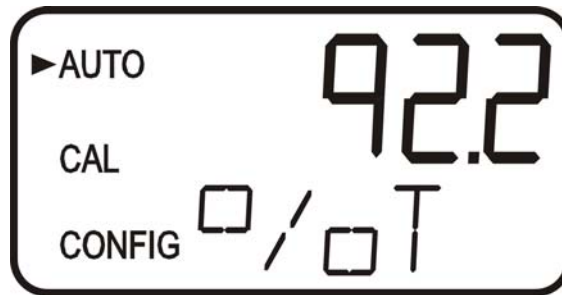

4.1 Warm-up

Upon power-up the AccUView will require a warm-up period of about 60 minutes. For improved accuracy allow the AccUView to complete warm-up time prior to calibrating. During the warm-up period, the display may flash indicating that it has detected a temperature change. It is normal for this to occur during the warm-up period

4.2 Routine Measurement

The following steps describe how to measure the % T of a sample using this instrument:

1. Apply power to the instrument and allow the unit an initial warm up of 1 hour.
2. When a continuous process stream is flowing through the instrument, the instrument will display the measured % T level of the sample by displaying it on the LCD screen. In addition, the equivalent signal is provided on the analog (4-20 mA) output, or the digital output, depending on the options selected.

Note: A flashing display may occur after warm-up. This is an indication that either the ambient or the water temperature or has changed rapidly. During this time the readings may be slightly out of the specified accuracy. The AccUView will automatically compensate as soon as the rate of temperature change slows.

4.3 Security Access Feature

The instrument is equipped with a security access code feature that can be activated in the configuration mode. If the security feature is enabled, the screen shown in the illustration below will appear when the **MODE/EXIT** button is pressed.

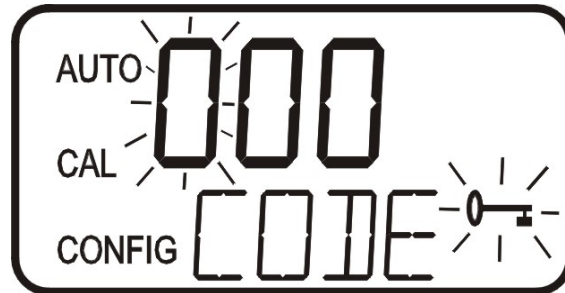

The security code (333) must be entered to gain access to **CAL** or **CONFIG** menus. Notice that the first number in the code is flashing. The flashing indicates that this is the number to be entered. Use the **▲** or **▼** arrows to select the first of the three numbers in the code and then press the **↵** button to accept the first number of the code. Now enter the second number in the code. Proceed as with the first number followed by **↵**. Then repeat the process for the third number in the access code, and finish with the **↵** button.

If the valid access code has been selected, the instrument will be directed to the calibration mode. If the wrong access code is selected, the instrument will return to the **AUTO** mode. Refer to section [7.6 Enabling the Security Access](#) for more information.

5.0 Instrument Calibration

The instrument was calibrated and tested prior to leaving the factory. Therefore, it is possible to use the instrument directly out of the box. Under normal conditions, re-calibration is recommended at least once every month. To get the greatest accuracy, you may need to calibrate once per week.

Two cuvettes are supplied with the instrument so that they can be exchanged with each other. One cuvette should always be kept clean for replacement when calibrating.

Relay contacts are held at the last valid condition and will not change state while the instrument is in the calibration and/or in the configuration mode. While in the calibration mode, the instrument has a time-out feature that automatically returns the system operation to the **AUTO** mode after a fifteen (15) minute period of inactivity.

5.1 100%T Calibration

1. Select the calibration function of the instrument by pressing the **MODE/EXIT** button once. The arrow beside **CAL** will be illuminated on the display. The lower display shows alternating **100** (indicating that the 100%T standard is requested) and ↵.
2. Close off the flow of water using the shutoff clamp.

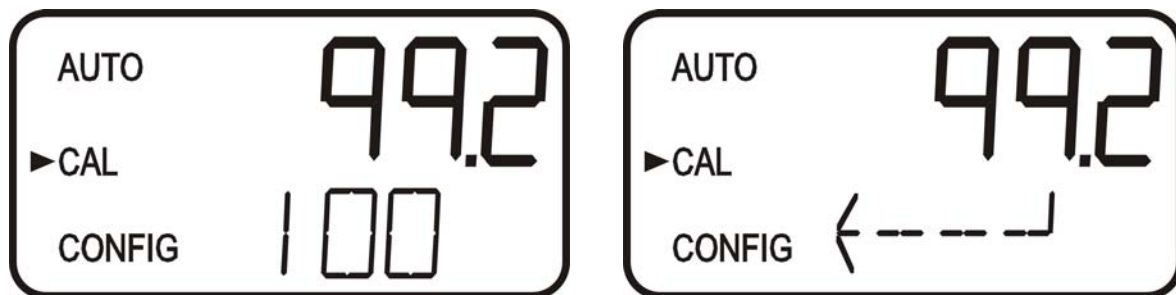

3. Remove the flow through cuvette, and retain for future cleaning.
4. Fill the second cuvette with 100% T calibration fluid and reinstall the filled cuvette on the flow through unit.
5. Wipe flow through unit dry, install and lock in place.
6. Press the ↵ button to accept the calibration.
7. The lower display will count down the progress of the calibration step (from 60).
8. The instrument will return to **AUTO** mode at the end the calibration.
9. After the instrument has returned to **AUTO**, the flow may be restored.
10. Do not move flow head after calibrating.

Note: It is recommended that the flow through unit be removed for as short an interval as possible to prevent premature saturation of the desiccant.

Warning: While the UV lamp is of very low power, do not look directly into the optical well while the flow through unit is removed.

5.2 100%T Calibration Error

If the screen shown below is displayed after the 100%T calibration, the internal diagnostics have determined that the calibration fluid requires replacement or the flow through cuvette requires replacement. Check, the calibration fluid & cuvette, then recalibrate or restore the factory calibration see [6.1 Restoring Factory Settings](#). The instrument cannot be used without performing one of these operations.

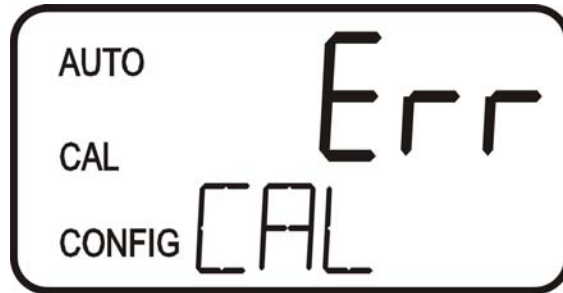

To recalibrate press the MODE key and start the calibration sequence again. To restore the factory calibration, push and hold the \blacktriangle button. Now push and release the \blacktriangledown then release the \blacktriangle button.

6.0 Instrument Offset

In certain instances, it may be desirable to use an offset factor to calibrate the instrument rather than performing a physical calibration of the instrument (as described in section 5.1). This procedure is not recommended in lieu of regular instrument calibration but it can be used in situations where the number of instruments used makes regular calibration prohibitive. This calibration technique will make the instrument accurate *only* at levels near the measured value of the grab sample and *not* in the full range of the instrument. Note that the **OFFSET** icon will be illuminated whenever an offset used. The maximum offset is $\pm 1.0\%$ T. If instrument variation is greater than 1% T a full calibration is recommended.

The procedures are as follows:

1. Collect a grab sample of the process water that is being monitored by the instrument and record the reading reported by the AccUView.
2. Take the grab sample and measure its value using a laboratory photometer (contact the HF scientific, inc. customer services department for examples of laboratory photometers).
3. Compare the reading reported by the AccUView to that obtained in the laboratory. If the readings are very close, then no offset adjustment or calibration is required and the procedure may be stopped at this step. However, if the readings are substantially different (but less than 1% T) continue on in this procedure to utilize the offset option to improve the reading of the AccUView so that it will agree with the laboratory reading between calibrations.
4. Select the offset function of the instrument by pressing the **MODE/EXIT** button until the arrow beside **CONFIG** is illuminated on the display. Refer to the following screen.
5. Push the \downarrow button until **OFST** is displayed on the lower row.
6. At this point, the lower row of the display will indicate the operational status of the offset function (**On** or **OFF**). Change this status by using the \uparrow and \downarrow buttons. Once the desired operational status of the offset function has been set, press the \downarrow button to accept it. If the option was turned off, return to **AUTO** mode by pressing **MODE/EXIT**.



7. If the option was turned **On**, the upper row will display the offset required. This will add or subtract the value of the offset to the measured % T value. As an example if the AccUView measures the process at 92.6 % T but the laboratory instrument read the sample at 92.2 % T, adding an offset of -0.4 would result in the AccUView displaying 92.2 % T.

Select the desired offset level using the ▲ and ▼ buttons. Once the desired level has been set, press the ↵ button to accept it.

8. This completes the offset configuration.
9. At this point, the instrument will continue through the configuration (**CONFIG**) mode of the instrument or press **MODE/EXIT** to return to the **AUTO** mode.

6.1 Restoring Factory Settings

If the instrument is unable to perform a calibration due to a low lamp output, bad calibration standard or a dirty cuvette, the instrument will display **CAL** on the lower row of the display and **Err** on the upper row. The operator has two choices to correct this problem. If the operator can determine whether a poor calibration or a low lamp caused the problem, he/she can remedy the problem and recalibrate. If all else fails, the operator may restore the factory calibration and configuration settings by performing the following operation. Push and hold the ▲ button. Now push and release the ↵ then release the ▲ button. Factory calibration and factory configuration have now been restored.

Note: Restoring the factory settings allows the use of the AccUView with reduced accuracy. The original problem still exists and must be determined and corrected before accurate operation of the AccUView will be resumed.

7.0 Instrument Configuration (CONFIG mode)

The instrument has been designed to provide the ability to customize the instrument according to needs at any time during normal operation. This mode has been split into sub-menus to facilitate instrument configuration. This section describes how to use each of the sub-menus to configure the instrument. While in the configuration mode, the instrument has a time-out feature that automatically returns the system operation to the **AUTO** mode after a fifteen (15) minute period.

Enter the **CONFIG** mode of the instrument by pressing the **MODE/EXIT** button until the arrow beside **CONFIG** is illuminated, then press the \downarrow button.

Note: To exit the **CONFIG** mode, press the **MODE/EXIT** button.

7.1 Selecting the Output (O/P)

The first configuration selection is the **O/P**. The selections are **4-20** for the 4-20 mA output, **485** for the RS-485 and **OFF** if no outputs are required. Select the desired output by using the \uparrow and \downarrow buttons. Once the desired output has been set, press the \downarrow button to accept it. The next prompts will depend on the output selected.

7.2 Setting the 4-20 mA

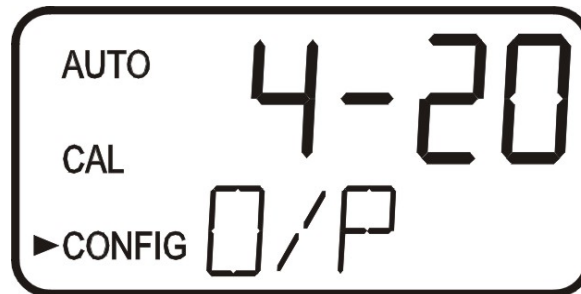

If the 4-20 mA output was turned on, prompts to set the lower (**LOLM**) and upper (**UPLM**) % T limits corresponding to the 4 mA and 20 mA output levels will be displayed. The first prompt will be the limit assigned to the 4 mA output level:

Select the level to assign to the **LOLM** using the \uparrow and \downarrow buttons.



Once the desired level has been set, press the \downarrow button to accept it.

The next, prompt will be the level assigned to the 20 mA output level (**UPLM** on the lower row of the LCD display). Select the % T level to assign to the **UPLM** using the **▲** and **▼** buttons. Once the desired level has been set, press the **↵** button to accept it.

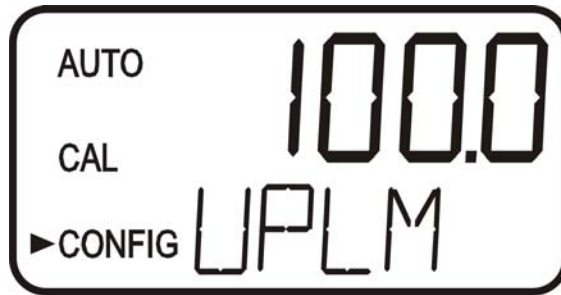

7.3 Configuring the RS-485 Port

If the instrument is equipped with this option (HF cat#19851A), and the I/O selection is changed to **485**, prompts will appear for setting the baud rate and the address.

Select the correct baud rate (1200, 2400, 4800, 9600, or 19200) for operation of the I/O port by pressing the **▲** or **▼** buttons to change the displayed baud rate.

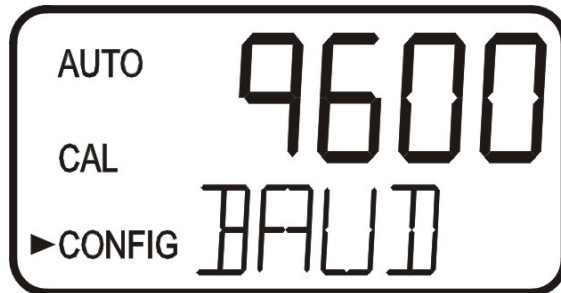

Press the **↵** button to continue on and select the desired instrument address using the **▲** or **▼** buttons. Once the selection is satisfactory, press the **↵** button.



To enable the Modbus mode, select **ASCII** or **RTU**. For more information refer to the Modbus Manual (Catalog #24570). The manual is also available as a free download from our website at www.hfscientific.com.

7.4 Configuring the Alarms

Two relays are provided that are designed to operate as two independent programmable alarms. Three types of information must be input to fully program each alarm:

1. The alarm function (HI, LO, or OFF)
2. The alarm set point (level at which the alarm activates)
3. The delay time for the alarm: the time that the set point must be exceeded prior to alarm activation and the time before resetting the alarm (prevents ringing in the relay).

These three items are described below:

Alarm Function: The alarms can either be turned OFF or programmed to operate in one of two different manners:

1. HI alarm: the relay changes state when the measured % T level is higher than the programmed alarm level for a prescribed amount of time.
2. LO alarm: the relay changes state when the measured % T level is lower than the programmed alarm level for a prescribed amount of time.

Note: The relays automatically change state when an internal system failure is detected.

Alarm Set Point: The level at which an alarm activates is called the alarm set point. On the instrument, the alarm set point is designated as “S/P”. The set point is adjustable to any valid level over the range of the instrument in steps of 0.1% T .

Alarm Delay Time: The alarm delay times are used to prevent ringing of the alarm when the measured level is close to the set point. The function of the delay times is as follows:

Delay On: The level must exceed the alarm set point continuously for at least this number of seconds before the alarm activates.

If the delay on time is set at 5 seconds and the process exceeds the set point continuously for only 4 seconds, the alarm will not be activated. However, if the process exceeds the set point continuously for 5 seconds or more, the instrument will activate the alarm.

Delay Off: The level must not exceed the alarm set point continuously for at least this number of seconds prior to deactivation of the alarm.

If the delay off time is set to 5 seconds and the process has exited out of the alarm condition, the alarm will be reset only if the process is out of the alarm condition for a continuous 5 seconds. Otherwise, the instrument will still signal an alarm condition.

7.4.1 Alarm 1

Alarm 1 Function: The **ALM1** is displayed and the display indicates the current function of alarm 1 (**HI**, **LO**, or **OFF**). Use the **▲** or **▼** buttons to cycle through and select the desired function. Press the **↵** button to accept the selection.

If the alarm was turned **OFF** a prompt will appear to set up alarm 2 (go to section **7.4.2**). If, on the other hand, one of the other functionalities was selected a prompt will appear to set the delay times.

Alarm 1 Set Point: This prompt is used to select the set point for this alarm; this is indicated by “S/P” shown on the lower row of the display. Select the desired alarm level by using the ▲ and ▼ buttons. Once the desired set point has been set, press the ↵ button to accept it.

Alarm 1 Delay Times: Delay On: The following display will appear to allow to select the number of seconds currently set for the “delay on” time.



The current selected number of seconds will be shown. Select the desired number of seconds for the “delay on” time for this alarm using the ▲ and ▼ buttons. Once the desired delay time has been set, press the ↵ button to accept it.

Delay Off: Next, the following display will appear to select the number of seconds currently set for the “delay off” time.

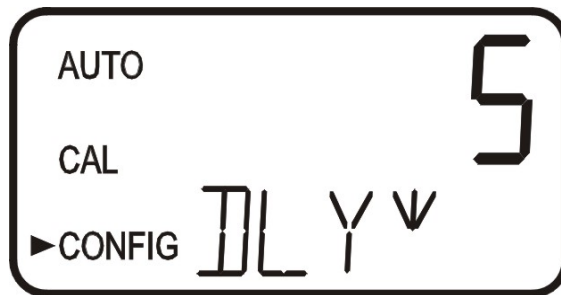

The current selected number of seconds will be shown. Select the desired delay off time for this alarm using the ▲ and ▼ buttons. Once the desired delay time has been set, press the ↵ button to accept it. After the settings for alarm 1 have been completed, prompts will allow for the set up of the information on alarm #2.

7.4.2 Alarm 2

Repeat the procedure listed in section 7.4.1 to set up the parameters for alarm 2. If a selection was made to turn the alarm **OFF**, the next selection for the speed of response **RESP** is shown. If one of the other functionalities is selected, a prompt to set the delay times and the set point, as with Alarm #1, will be displayed.

7.5 Offset Calibration

Refer to section 6.0 for more information on this selection.

7.6 Enabling the Security Access

The instrument is equipped with a security access. If this option is turned on, the user is required to input the access code into the instrument to get to any mode other than **AUTO**. The only code is **333**. This code may not be changed. See section 4.2 for more information on this security feature. The security key icon will be visible and flashing on the display whenever the access option is selected using the \blacktriangle or \blacktriangledown buttons. (**On** or **OFF**).

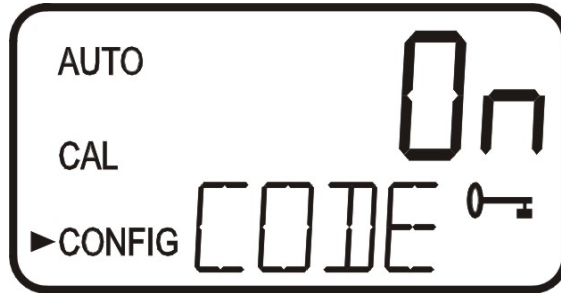

7.7 Extended Settings

The last few settings are grouped together to prevent them from being adjusted by accident. To gain access to the extended settings, select **On** using the \blacktriangle or \blacktriangledown buttons and press the \blacktriangleleft button.

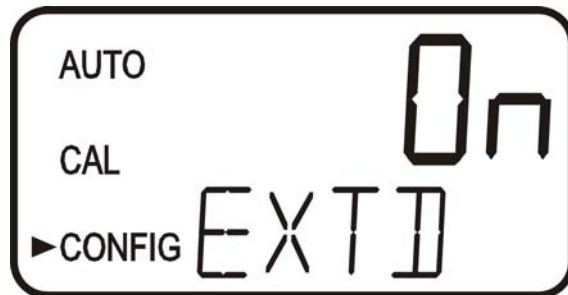

7.8 Speed of Response

The speed of response for both displayed and output values can be adjusted in this menu. The default setting is 10 however, 100 response speeds are available. Select the desired speed of response using the \blacktriangle and \blacktriangledown buttons. Press the \blacktriangleleft button to accept it.

To avoid reading air and other anomalies, select the slowest speed (highest number). Select the fastest response where monitoring of rapid changes is needed.



7.9 LCD Backlight Brightness

The LCD backlight brightness may need to be adjusted. This is of particular interest if multiple instruments are located in the same area and it is desired for the entire group to have the same appearance. Ten levels are available. The default brightness is 8.

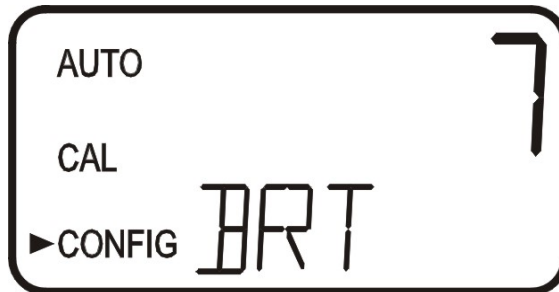

Change the brightness by pressing the \blacktriangle or \blacktriangledown button. When the desired brightness has been selected, press the \blacktriangledown button.

7.10 Ultrasonic Cleaning

This allows for a selection menu to turn **OFF** the ultrasonic cleaning function if desired. The default mode is **On**. Make a selection using the \blacktriangle and \blacktriangledown buttons then press the \blacktriangledown button.



7.11 RS-485 Parameter - Bits

This is the first of three menus to setup the RS-485 parameters. These menus will only appear if the RS-485 mode is selected. Selections are 7 or 8 bits. The default selection is 8 bits. Make a selection using the \blacktriangle and \blacktriangledown buttons then press the \blacktriangledown button.



7.12 RS-485 Parameter – Parity

In the Parity menu selections are no parity (nOnE), odd parity (Odd) or even parity (E). The default selection is no parity. Make a selection using the \blacktriangle and \blacktriangledown buttons then press the \blacktriangledown button.

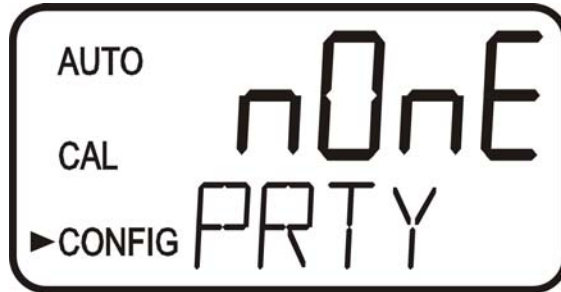

7.13 RS-485 Parameter – Stop Bits

For stop bits the choices are 1 or 2 stop bits. The default selection is 1 stop bit. Make a selection using the \blacktriangle and \blacktriangledown buttons then press the \blacktriangledown button.



7.14 Lamp Duty Cycle

This determines how often the lamp turns on and updates the reading. The lamp will operate for 2 seconds each time to obtain readings. Updates can be set from 4 seconds to 60 seconds. The default setting is 10. Keep in mind that this setting also affects the life of the lamp. With updates set to 4 seconds the lamp life is about one year. The default 10-second update will extend the lamp life to over 2 years. The 60-second setting increases lamp life to about 14 years.

Change the selected update period using the \blacktriangle and \blacktriangledown buttons then press the \blacktriangledown button.

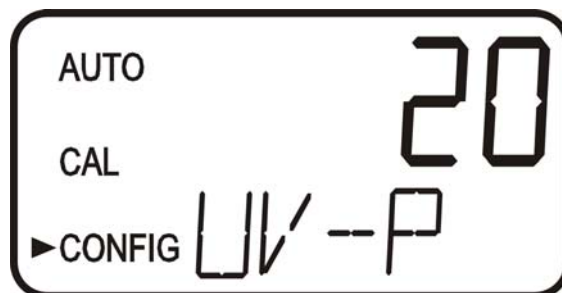

7.15 Desiccant Alarm

When the humidity detector in the AccUView indicates that the internal environment is close to the point where humidity could cause condensation, the instrument will display **DESC** as a warning. If desired, a desiccant warning can activate the alarms and send the 4-20mA to 2mA. To activate the alarms when the desiccant fails, select **On** in the **DESC** menu. The default for this menu is **OFF**. Make selections using the **▲** and **▼** buttons then press the **↵** button to move to return to **AUTO** mode.



7.16 Saving Configuration Settings

If extended settings is set to **OFF**, pressing the **↵** button will save all settings and the AccUView will automatically return to the normal **AUTO** mode of the instrument.

If extended settings is set to **On**, after the last menu of the extended settings, pressing the **↵** button will save all settings and the AccUView will automatically return to the normal **AUTO** mode of the instrument.

The **CONFIG** menu may be used at any time to reset or change any of the parameters. The **CONFIG** menu may be exited at any point in the menu by using the **MODE/EXIT** key. Any features that have been modified will be saved.

8.0 Additional Features and Options

8.1 Backlit LCD

The backlit LCD allows for easier readability of the LCD display in low light or no light conditions. The backlight is intended for continuous operation. The brightness is adjustable from a menu in the **CONFIG** mode.

8.2 Ultrasonic Cleaning

This option is used to continuously clean the flow through cuvette. It is not intended to clean cuvettes that are already dirty, or replace manual cleaning entirely. The system will increase the time between cleanings dramatically. Please note that the system requires the use of a special cuvette. This cuvette must be used for the system to operate correctly.

The system works by sending an ultrasonic frequency through spring connections into a piezo transducer bonded to the bottom of a flow through cuvette.

The system can detect that an incorrect cuvette is installed, an error has occurred in the transducer or the transducer is not making contact with the spring connections. This error is indicated by **CLN** being posted to the lower screen. Since this is an error condition, the alarms will be set and the 4-20 mA will be sent to 2 mA.

If the correct cuvette is installed, and the error is still posted, try rotating the flow through unit slightly to improve the connection. If this fails to work, the cuvette may have to be replaced (Catalog #24232S). The detection for this cuvette only operates in **AUTO** mode. If the system is operating correctly **AUTO** will flash.

After installing a cuvette, there will be a 30 minute period where the lower screen will post **DRY** to the lower screen. During this time, the ultrasonic circuit will not operate to allow the Vapor Purge system to remove all moisture from the ultrasonic transducer. This is normal and is not considered an alarm condition so no alarms will be implemented. If the cuvette is removed during this period no **CLN** alarm is posted until the 30 minute **DRY** period times out.

Even with the above drying system, it is still recommended that Ultrasonic cuvettes be dried by hand, including the transducer on the bottom prior to use.

8.3 RS-485 Outputs (Catalog #19851A)

The AccUView has the capability to operate in three different RS-485 modes. Included is a mode for interfacing into the HF Online software package (section 8.3.1 below), and a simple communication mode. A third operating mode is the Modbus communications. All modes will automatically configure and do not require any changes or selections. Factory installed option cat. #19851A is required for RS-485 operation.

8.3.1 HF Online (HF catalog # 19783)

The AccUView can operate as a small SCADA system with an optional PC software package, called HF ONLINE. This system allows for an interface with up to 255 AccUView's for the purpose of data logging. This system will interface directly with common database and spreadsheet software.

8.3.2 Simple Communication

The AccUView can provide basic communications over simple programs such as the Hilgraeve HyperTerminal that is included with most Microsoft Windows packages. The user could also use Visual Basic or other programs. The default communication parameters are 8 bits, no parity and 1 stop bit. These parameters may be changed in the extended **CONFIG** menu.

The master computer will send out:

- Byte #1 the attention character “:” in ASCII or **3A** Hex
- Byte #2 the address of the AccUView being queried
- Byte #3 & 4 CR LF or 0D 0A in hex

The AccUView will respond with:

- The same attention character “:” in ASCII or **3A** Hex
- The address of the AccUView
- The Reading
- The Unit (% T)

A sample communication would look like this:

(Master computer requesting a report from address #1) **: 1 CRLF**
(AccUView set to address #1 Response) **:001 97.4 %T**

8.3.3 Modbus Communication

Modbus communications is fully operational if the RS-485 option (Catalog #19851A) is installed. The Modbus protocol communication information is covered in a separate manual (Catalog #24570). This manual is available as a free download from our website at www.hfscientific.com.

8.4 Flow Alarm (Catalog # 19945A)

The flow switch for the AccUView is a factory-installed option. This option indicates a “Low Flow” condition by switching both relays to the fail state and setting the 4-20 mA signal to 2 mA. There is also a screen indication of the low flow condition and a modbus register is set.

8.5 Remote Panel Meter (Catalog # 19609)

The remote panel meter allows for remote indication of the % T reading using the 4-20 mA loop. No external power is required as the meter is run off of the 4-20 mA source.

9.0 Routine Maintenance

9.1 Cleaning the Flow Through Cuvette

Measurement cuvettes used for the flow through should be clean and free of marks or scratches. Cleaning is accomplished by cleaning the interior and exterior with a detergent solution and then rinsing several times with distilled or de-ionized water. The cuvette can be replaced by first shutting off the flow using the provided shutoff clamp; unscrewing the old cuvette and replacing with a fresh clean one. Recalibration will be required for accurate operation.

9.2 Replacing or Installing the Desiccant Pouch

The AccUView continuously checks the condition of the desiccant tray. When the desiccant gets in such a condition that it may cause problems, the instrument will display **DESC** on the lower portion of the display to indicate the presence of humidity.

Proper use of the supplied desiccant is essential in maintaining the performance of the instrument. The desiccant has been designed to have a long life; however, replacement of the desiccant pouch will be required from time to time.

It is essential that all enclosure seals be maintained to ensure adequate desiccant life. The emergency drain and o-rings that are supplied with each new instrument, form part of the instrument humidity seal. Other seals are in the sensor bottom and the O-ring under the flow through unit. Inspect these items each time the desiccant pouch is replaced. Replace any parts found to be defective.

The desiccant should be replaced when the instrument displays **DESC**. A new sealed desiccant pouch and indicator card are available from HF scientific inc. part #21555R. To initially install or remove the old desiccant, simply unscrew the four corner thumbscrews and remove the electronics half of the instrument. Open the bag protecting the new desiccant pouch and replace (or install) immediately. To speed up the recognition, by the instrument, of the new desiccant it will be necessary to reset the instrument by disconnecting the sensor interconnect cable for 2 seconds and then reconnecting it.

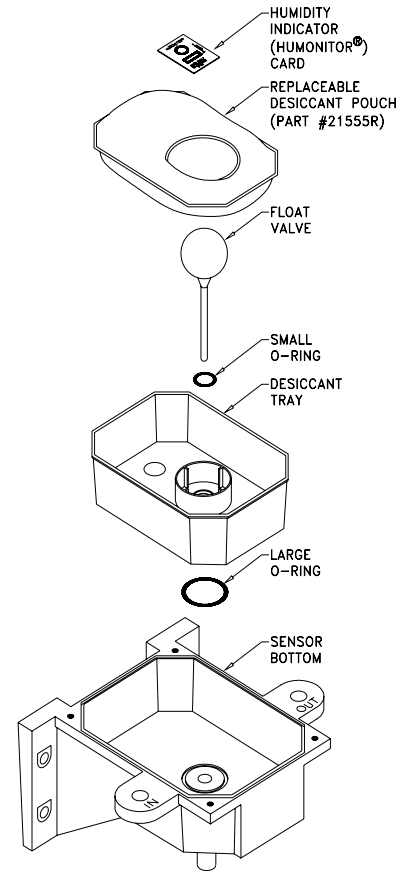

Note: Once the bag is opened, install the desiccant pouch immediately to prevent premature degradation of the desiccant.

9.3 Replacing the Source Lamp

The UV source lamp in the AccUView has a variable life dependant on the setting of the Lamp Duty Cycle. See section 7.14 for more information on the lamp life

Due to safety concerns it is recommended that the electronic service module be exchanged - Part# 01957S. Whenever the UV source lamp requires replacement an economical exchange program is available. Call the HF Customer Service Department for assistance.

10.0 Troubleshooting

10.1 AccUView Fault Detection

The AccUView performs continuous diagnostic monitoring. In the AccUView there are three levels of fault detection; warnings, errors and failures. Any faults are displayed in a queue form in the bottom row of the LCD.

A **warning** is simply a screen indication of a problem. No alarms are activated. If the desiccant alarm is turned off and the desiccant becomes saturated, a screen warning of **DESC** will appear. At power-up for 30 minutes and at operating temperatures outside of our specifications, the %T reading may flash. When this happens the reading may be outside of the stated tolerance.

An **error** indicates a fault or a problem that usually can be corrected by the operator. These errors consist of lamp low output (**LAMP**), 4-20 mA loop open (**MA**), bad 100% T calibration (**CAL Err**), bad temperature compensation calibration (**TECO**), if desiccant alarm activated and replacement required (**DESC**), if enabled no flow (**FLOW**) (if equipped with the optional flow switch). An additional message will indicate that the ultrasonic transducer is not making contact or the flow through has been removed (**CLN**). If any of these conditions occurs, both alarm relays will be activated and the 4-20 mA output will be held at 2 mA. If any of these errors occur the instrument will still display readings, however the accuracy is not known and the instruments readings should not be trusted.

A **failure** is a system fault. This is NOT a problem that the operator can correct, and the unit must be returned to the factory for service. These failures consist of failures in the CPU, A/D, EEPROM or other devices internal to the instrument (**FAIL**). If a failure occurs, the instrument will not function properly and will display the word FAIL on the lower row, both alarm relays will be activated and the 4-20 mA output will be held at 2 mA (if 4-20 mA is selected).

If any fault conditions occur, the message indicating the fault will be shown on the lower row of the display.

10.2 System FAIL Message

Normally, this condition indicates that the instrument will require servicing. Contact either the HF scientific, inc. Technical Service Department or the HF scientific, inc. Customer Service Department.

HF scientific, inc.
3170 Metro Parkway
Fort Myers, Florida 33916-7597
Phone: (239) 337-2116
Fax: (239) 332-7643
Email: info@hfscientific.com
www.hfscientific.com

10.3 Diagnostic Chart

Symptom	Cause	Cure
Lower display shows MA	4-20 mA loop open	Check wiring. See sections 3.3.4 and 7.2
Lower display shows DESC	Desiccant pouch bad	Change desiccant pouch. See section 9.2
Lower display shows LAMP	Lamp failed	Replace lamp. Refer to section 9.3
Lower display shows FLOW (if flow option installed)	Sample flow has stopped	Restore flow.
Lower display shows CLN	Ultrasonic cleaning failure	Refer to section 8.2
Lower display shows CAL Err after a calibration.	100% T Calibration failure	Refer to section 5.2
Lower display shows TECO	Temperature Compensation Calibration failed	Attempt another Temperature Compensation Calibration. If this fails again contact HF scientific inc. service dept.
Lower display shows FAIL	Major system fault	Refer to section 10.1 & 10.2
Readings are lower than expected	<p>(1) Bubbles in solution</p> <p>(2) Condensate or leaky cuvette</p> <p>(3) Flow through cuvette dirty</p> <p>Instrument out of calibration</p>	<p>(1) Ensure that the drain vent is open and is not obstructed. See section 3.2.2.</p> <p>(2) Apply backpressure. See section 3.2 and figure 4</p> <p>(3) For sever cases of bubbles a stilling chamber is available. Call HF scientific. Part# 20106</p> <p>Check flow through cuvette for condensate or leaks.</p> <p>Clean cuvette. See section 9.1</p> <p>Recalibrate. Refer to section 5</p>
Readings are erratic	<p>(1) Bubbles in solution</p> <p>(2) Debris in flow through</p>	<p>(1) See above</p> <p>(2) Clean debris from cuvette</p>
Readings are lower than expected	Instrument out of calibration	Recalibrate. Refer to section 5

10.4 Technical and Customer Assistance

If for any reason assistance is needed regarding this instrument please do not hesitate to contact either the HF scientific, inc. Technical Service Department or the HF scientific, inc. Customer Service Department. Contact information is shown on section 10.2.

11.0 Accessories and Replacement Parts List

The items shown below are recommended accessories and replacement parts.

Accessory	Catalog Number
Replacement Desiccant Pouch	21555R
100 % T Calibration Solution - 500 ml	19323
UV Lamp Replacement Module (Exchange price item-no discounts)	01957
Quartz Replacement Cuvette with Ultrasonic Transducer	24232S
Operating Manual, AccUView	24238
HF Online Software for data collection and reporting	19783
Flow Regulator, 1000ml/min.	19778
Pressure Regulator	24306S
Flow Alarm Factory Installed Option (Provides an alarm if sample flow is interrupted).	19945A
Tubing Kit Containing: 1-shutoff clamp, 1-backpressure valve, 2-connecting tubings with fittings for flow through assembly, drainvent.	21062

To order any accessory or replacement part, please contact the HF scientific, inc. Customer Service Department. If for any reason technical assistance is needed regarding this instrument please do not hesitate to contact the HF Technical Services Department.

HF scientific, inc.
3170 Metro Parkway
Fort Myers, Florida 33916-7597
Phone: (239) 337-2116
Fax: (239) 332-7643
Email: info@hfscientific.com
www.hfscientific.com

12.0 Warranty

HF scientific, inc., as vendor, warrants to the original purchaser of this instrument that it will be free of defects in material and workmanship, in normal use and service, for a period of one year from date of delivery to the original purchaser. HF scientific, inc.'s, obligation under this warranty is limited to replacing, at its factory, the instrument or any part thereof. Parts, which by their nature are normally required to be replaced periodically, consistent with normal maintenance, specifically reagent, desiccant, sensors, electrodes and fuses are excluded. Also excluded are accessories and supply type items.

Original purchaser is responsible for return of the instruments, or parts thereof, to HF scientific, inc.'s factory. This includes all freight charges incurred in shipping to and from HF scientific, inc.'s factory.

HF scientific, inc. is not responsible for damage to the instrument, or parts thereof, resulting from misuse, environmental corrosion, negligence or accident, or defects resulting from repairs, alterations or installation made by any person or company not authorized by HF scientific, inc.

HF scientific, inc. assumes no liability for consequential damage of any kind, and the original purchaser, by placement of any order for the instrument, or parts thereof, shall be deemed liable for any and all damages incurred by the use or misuse of the instruments, or parts thereof, by the purchaser, its employees, or others, following receipt thereof.

Carefully inspect this product for shipping damage, if damaged, immediately notify the shipping company and arrange an on-site inspection. HF scientific, inc. cannot be responsible for damage in shipment and cannot assist with claims without an on-site inspection of the damage.

This warranty is given expressly and in lieu of all other warranties, expressed or implied. Purchaser agrees that there is no warranty on merchantability and that there are no other warranties, expressed or implied. No agent is authorized to assume for HF scientific, inc. any liability except as set forth above.

HF scientific, inc.
3170 Metro Parkway
Fort Myers, Florida 33916-7597
Phone: (239) 337-2116
Fax: (239) 332-7643
Email: info@hfscientific.com
Website: www.hfscientific.com

MOUNTING TEMPLATE

ALL DIMENSIONS ARE IN MILLIMETERS (INCHES)

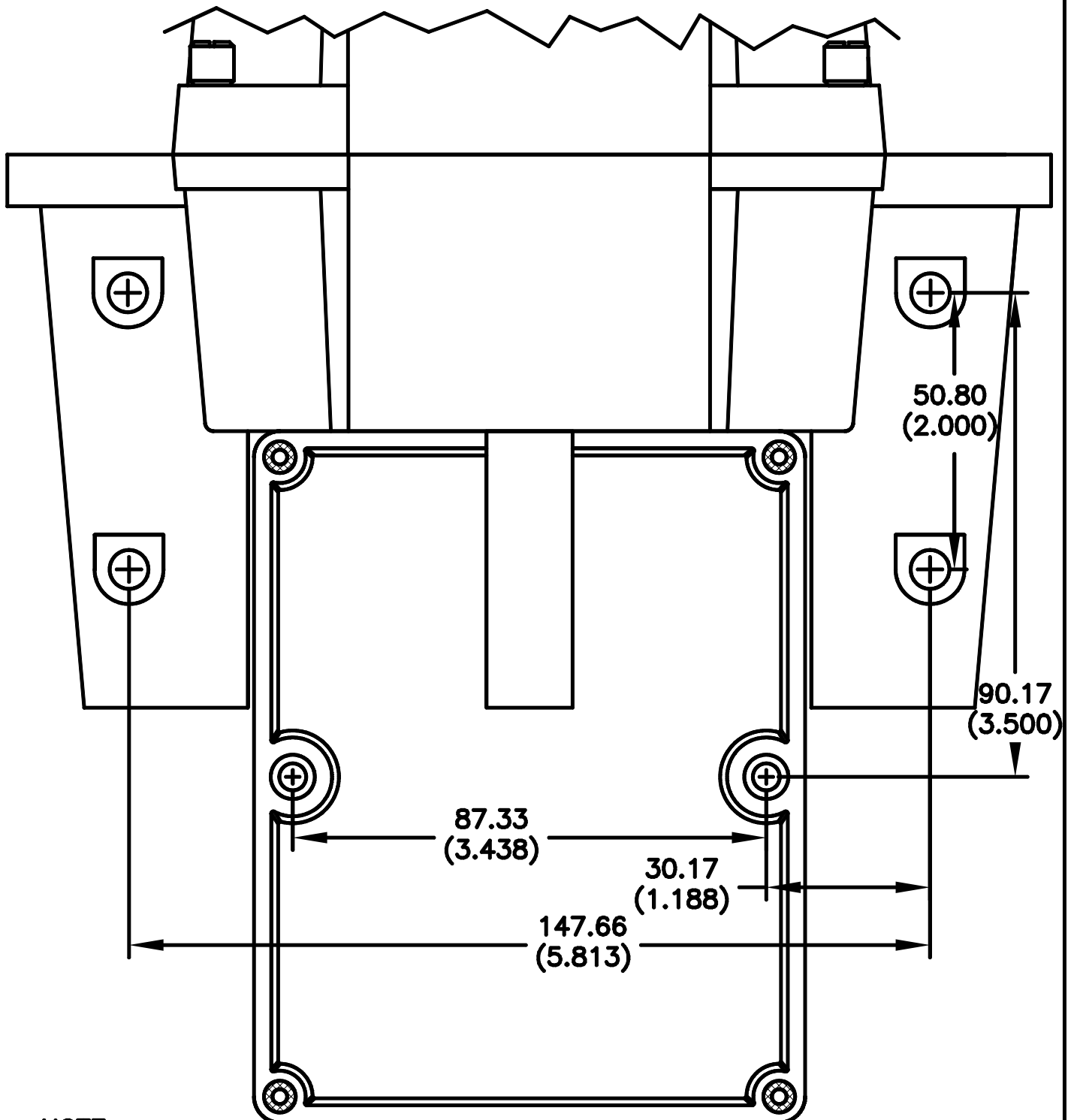

NOTE:

- 1) SEE THE MOUNTING INSTRUCTIONS IN THE MANUAL FOR MOUNTING HARDWARE SIZES.
- 2) PROVIDE AT LEAST 200 MM (8 INCHES) OF FREE SPACE ABOVE THE SENSOR FOR EASY REMOVAL OF THE FLOW HEAD AND INSERTION OF THE CALIBRATION STANDARDS.