



Pollardwater(dot)com

Phone 800-437-1146
Fax 425-861-7235
info@pollardwater.com

West Coast Branch
17515 NE 67th Ct
Redmond, WA 98052

East Coast Branch
200 Atlantic Ave
New Hyde Park, NY 11040

WS750 Sampler

Table of Contents

I.	WS750 Checklist	•	•	•	•	•	•	Page	3
II.	Inspection	•	•	•	•	•	•		3
III.	Description	•	•	•	•	•	•		4
IV.	Installing the Water Sampler			•	•	•	•		5
V.	Installing the Pickup Hose	•	•	•	•	•	•		5
VI.	The Control Panel	•	•	•	•	•	•		6
VII.	Composite Sampling			•	•	•	•		8
VIII.	Discrete Sampling	•	•	•	•	•	•		8
IX.	Mixed Sampling	•	•	•	•	•	•		9
X.	External Trigger mode			•	•	•	•		9
XI.	Specifications	•	•	•	•	•	•		11
XII.	Maintenance	•	•	•	•	•	•		12
XIII.	Troubleshooting	•	•	•	•	•	•		13
XIV.	Warranty	•	•	•	•	•	•		14
XV.	Appendix A: Sample Size vs. Head Height			•	•	•	•		15
XVI.	Appendix B: Battery Life			•	•	•	•		16
XVII.	Appendix C: Input and Output Connection			•	•	•	•		16
XVIII.	Appendix D: Accessories	•	•	•	•	•	•		17

* Copyright © Global Water Instrumentation, Inc. 2006

Congratulations on your purchase of the Global Water WS750 Water Sampler. This instrument has been quality tested and approved for accurate and reliable operation. We are confident that you will find the WS750 to be a valuable asset for your applications. Should you require assistance, our technical staff will be happy to help.

I. WS750 Checklist

- a. WS750 Water Sampler
- b. 12V Battery (Inside Enclosure)
- c. Battery Cable
- d. Battery Charger
- e. Two Shorting Plugs
- f. WS750 Manual

II. Inspection

The WS750 unit was carefully inspected and certified by Global Water's Quality Assurance Team before shipping. If any damage has occurred during shipping, please notify Global Water Instrumentation, Inc. and file a claim with the carrier involved.

Use the checklist to ensure that everything needed to operate the WS750 was received.

III. Description

The Global Water WS750 Sampler is designed specifically to meet a wide variety of sampling requirements including industrial discharge, process control, water and wastewater treatment plants, sewers, rivers and streams.

The 750 Sampler can take two individual "time weighted" composite samples, or the sampler can be set to take full-bottle discrete or "Grab" samples. Each pump has its own sample bottle and control for setting the size of individual samples. This allows each pump to be set as either a composite or discrete sampler independently of the other or, in the case of two composite samplers, have different size settings for each pump.

A delay timer can be set to start sampling after a preset time. This allows multiple samplers to be deployed in the field and have them turn on at the same time. The delay can also be used to hold off sampling to let the water source flush out debris or other contaminants.

After each sample, the pumps will reverse for 15 seconds. This clears any debris from the strainer at the end of the pickup hose and also empties water from the hose so the next sample is not contaminated by the previous one.

Inputs are provided for triggering the sampler based on water level, a rain gauge sensor or signals from an external process controller or other monitoring device. Individual outputs are also available for monitoring when each of the pumps has taken a sample, using a data logger or similar recording device.

The WS750 Sampler is easily set up near industrial discharges or streams. It can also be suspended in a manhole for sewer flow sampling.

The Sampler consists of a rugged, rainproof and lockable carrying enclosure. The enclosure houses two peristaltic sampling pumps, two sample bottles, a control panel, and a rechargeable battery. A battery charger and sample pickup hoses are also provided.

IV. Installing the Water Sampler

- a. The sampler should be placed upright (it will not work if placed on its back or side).
- b. Open the sampler and remove the battery charger from the unit. Store the charger for later use.
- c. To secure the sample bottles:
 1. Screw the bottle cap/float switch onto the sample bottle
 2. Place the bottles into the sampler enclosure
 3. Insert the end of the peristaltic pump's hose in the hole at the top of the bottle cap
 4. Plug the float switch lead into the jack on the front of the control panel
- d. The sampling unit can be secured from vandalism and strong winds by one of the following methods:
 1. Mount unit on post and lock closed
 2. Lock closed and chain handles to a solid structure (such as a tree, post, or building)
 3. Enclose and lock unit in a steel electrical box
- e. Avoid drilling holes in the enclosure if possible. If holes must be drilled in the enclosure avoid drilling through the control panel enclosure. Any holes drilled through the enclosure must be sealed with some type of silicone glue to prevent water from entering the case and causing equipment failure.
- f. The unit is water resistant, not water proof. The unit must be located well above the expected water level to continue to provide reliable service.

V. Installing the Pickup Hose

The pickup hose should be installed in a wastewater discharge channel or stream. The pickup strainer should be submerged under water and should be situated to avoid contact with the channel bottom.

VI. The Control Panel

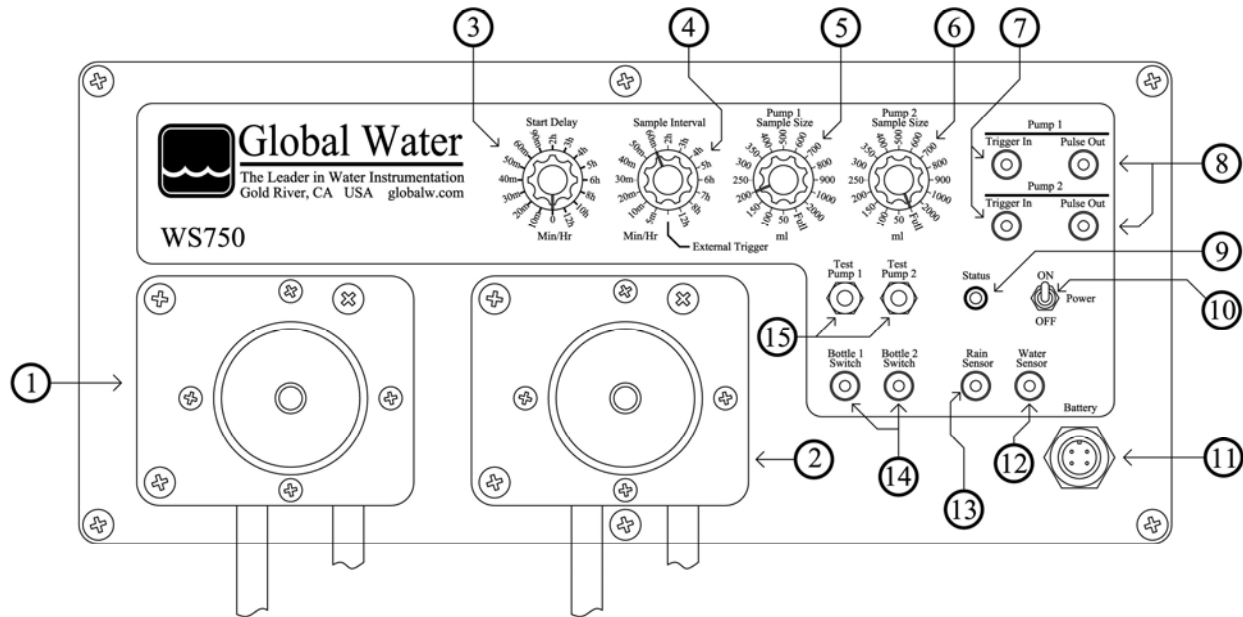

1. Pump One.
2. Pump Two.
3. Start Delay: This setting delays sampling by a preset amount of time. If no delay is desired, set the control to zero. Only the first sample taken by each pump is delayed, except as described later in the section titled "External Trigger Mode".
4. Sample Interval: Sets the time interval between composite samples. The "External Trigger" position is reserved for using the Trigger and Rain Sensor inputs to initiate sampling as described later in the section titled "External Trigger Mode".
5. Pump 1 Sample Size: Sets the size for a single composite sample with pump one. The sample size settings are approximate and apply to a head height of four feet. The switch position marked "Full" causes the pump to work as a discrete sampler, filling the bottle full in one sample. Note: In the "Full" position, the sampler will shut off the pump after one hour, even if the bottle is not full.
6. Pump 2 Sample Size: Sets the sample size for pump two and works the same as Pump 1 Sample Size described above.
7. Trigger In: These inputs work in "External Trigger" mode only, when selected by the Sample Interval control. A signal from an external device will cause a single sample to be taken by the corresponding pump according to its Size control. The External Trigger mode is described in

- more detail later in the section titled "External Trigger Mode". Refer to the Specifications section for details about the input pulse requirements.
8. **Pulse Out:** These outputs send a pulse to an optional recording or monitoring device each time the corresponding pump starts, allowing the time of the sample event to be recorded. Refer to the Specifications section for details about the output pulse.
 9. **Status:** This red LED indicates the status of the sampler. While the sampler is waiting to be triggered, the light remains off. Once triggered, the LED will blink once every two seconds while the Delay or Interval timers are running and while the pumps are operating. The LED remains lit constantly when both sample bottles are full or if the switches are not plugged in.
 10. **Power:** This turns the power to the sampler on and off. *Turning the switch off for one second resets all functions and timers.*
 11. **Battery:** Connect the battery here using the supplied battery cable.
 12. **Water Sensor:** When an optional water sensor is plugged into this jack, sampling will not begin until the presence of water is detected (the Rain Sensor must also detect water). If this sensor input is not being used, plug one of the two shorting plugs supplied with the sampler into this jack. This input has no affect when triggering the sampler with the Trigger Inputs in External Trigger mode.
 13. **Rain Sensor:** When an optional water sensor is plugged into this jack, sampling will not begin until the presence of water is detected, usually in a rain gauge (the Water Sensor must also detect water). If this sensor input is not being used, plug one of the two shorting plugs supplied with the sampler into this jack. This input has no affect when triggering the sampler with the Trigger Inputs in External Trigger mode. This input can also be used to take individual composite samples and is described in detail later in the section titled "External Trigger Mode".
 14. **Bottle Switches:** The sample bottle float switches plug into the control panel here. For sampling to occur, a float switch must be plugged in and the bottle must not be full. If the Status LED remains lit all the time, check these connections.
 15. **Test Pump:** Pressing one of these buttons tests the operation of the corresponding pump. These buttons will test the pumps operation regardless of whether a bottle switch is plugged in or not. The pump runs forward for as long as the button is held down, then reverses for an equal amount of time, or 15 seconds, which ever is less.

VII. Composite Sampling

A composite sample is a series of smaller samples put into the same bottle, thus showing an “average” sample over time. Set the Interval control to the desired time between samples (do not select the External Trigger position). Set the Size control for the corresponding pump to the desired sample size. Note that the sample size settings are approximate and apply to a head height of four feet. For heights other than four feet, refer to the chart inside the front of the sampler. Each pump can have different size settings but will share the same Sample Interval setting.

The sampler starts timing when both of the optional Rain and Water Sensors detect moisture. If you do not have the optional water sensors or do not need them for your application, defeat them by plugging one of the two shorting plugs supplied with the sampler into their jack. If both inputs are defeated, the sampler starts up triggered when the power switch is turned on. The Status LED starts blinking every 2 seconds once the sampler is triggered.

The Start Delay timer begins running when the sampler is triggered by the Rain and Water Sensors and the first sample is taken when the timer expires. If the Delay control is set to zero, sampling begins immediately. The delay timer only applies to the first sample taken by each pump. At the end of each sample, the pumps reverse for 15 seconds.

Sampling continues as Trigger-Delay-Sample-Reverse-Interval-Sample-Reverse-Interval-Sample-Reverse ... until the sample bottles are full. For each pump, the same amount of Interval time is placed between samples, even if the size settings are different. When both bottles are full, the Status LED remains lit constantly.

VIII. Discrete Sampling

A discrete sample is a single sample put into the same bottle, thus being a sample at one point in time. Set the Size control for the corresponding pump to “Full”. Once started, the pump will continue to run until the sample bottle is full.

As with composite sampling, the Start Delay timer begins when the sampler is triggered by the Rain and Water Sensors and the first sample is taken when the timer expires. If the Delay control is set to zero, sampling begins immediately. The Status LED blinks every 2 seconds while the delay timer or the pumps are running and remains lit constantly once both of the sample bottles have been filled. At the end of sampling, the pumps reverse for 15 seconds.

IX. Mixed Sampling, Composite and Discrete Sampler

The WS750 Sampler can be configured as both a composite and discrete sampler at the same time since each pump has a separate Size control. Set one pump's size setting to the desired composite sample size and the other to "Full".

Again, the Start Delay timer begins when the sampler is triggered by the Rain and Water Sensors and the first sample is taken when the timer expires. If the Delay control is set to zero, sampling begins immediately. The Status LED blinks every 2 seconds while the delay timer and the pumps are running and remains lit constantly once both of the sample bottles have been filled. At the end of each sample, the pumps reverse for 15 seconds.

X. External Trigger Mode

When the Sample Interval control is set to the "External Trigger" position, the sampler can be triggered externally by inputs from either the Trigger In jacks or the Rain Sensor input. This mode is useful in applications where sampling occurs based on readings from a process controller, SCADA system, flow monitor, auto-dumping rain gauge or other remote monitoring devices.

Using the Rain Sensor as a trigger source:

This mode is normally used with an auto-dumping rain gauge that empties itself every 24 hours. Set the Sample Interval control to External Trigger. Set each pump's Size control based on desired composite sample size or set to Full for a discrete sample.

The sampler will be triggered when both the Rain and Water Sensors detect moisture. If the Water Sensor is not needed, use one of the shorting plugs supplied with the sampler to defeat it by plugging it into the Water Sensor input jack. Place the Rain Sensor at the desired height in the rain gauge. When the Rain Sensor detects moisture, the sampler will start.

Once triggered by the Rain Sensor, the Start Delay timer begins running and the Status LED begins blinking every 2 seconds. When the timer expires, the pumps take a sample based on their individual Size settings. When the samples are complete, the pumps reverse for 15 seconds, then stop. The sampler cannot be re-triggered until the rain gauge empties itself and the Rain Sensor goes dry. The next time the sensor detects moisture, the Start Delay timer will start over again and another sample will be taken when it expires.

If a pump's Size control is set to take a full-bottle discrete sample, further triggers will have no affect on that pump. If a pump is set to take composite samples, each one will represent the conditions at the time of that "qualified rain event". This process will continue until both the sample bottles are full and the Status LED remains lit all the time.

Using the Trigger Inputs as a source:

These inputs are generally used for connecting to a flow monitor, processor controller, or other external monitoring device.

When using the Trigger In input jacks, leave the Rain Sensor input jack disconnected. Each of the two Trigger Inputs control the corresponding pump separately from the other.

Upon being triggered by one of the Trigger Inputs, the Start Delay timer begins running. When the delay timer has expired, the corresponding pump takes a sample based on its Size setting. Holding the Trigger Input active past the end of the sample will cause the pump to continue until the Trigger Input is released. When the sample is complete, the pump reverses, and then stops.

Flow Proportional Sampling

- a. To set the WS750 up to take flow proportional samples, a flow monitor must be attached to the control panel. In this configuration, the sampler is designed to take a sample every time a specific amount of flow has passed through the flow monitor.
- b. The flow monitor must provide a momentary switch closure (250ms or longer) or a pulse of 4-30VDC, whenever a sample is to be taken. The output of the flow monitor must be wired to a 2-wire RCA jack as shown in Appendix C. The phone plug is then inserted into the Trigger In jack on the control panel.
- c. Set the Sample Interval knob to External Trigger mode and the Sample Size knob to the desired sample size. The sample will be taken, flow proportionally, as directed by the flow meter.

XI. Specifications

Operating Temperature:	0° to +70°C
Size of unit:	22"H X 17"W X 9"D
Weight:	22lb (Shipping Weight 24lb)
Materials:	
Enclosure:	Expanded UV protected PVC
Bottles:	Two 1 gallon Polyethylene
Pickup Hose:	15' nylon reinforced 1/4" ID polyethylene flexible tubing section with intake strainer
Pump Tubing:	Neoprene 1/4" ID, 7/16" OD
Sample Pumps:	
Flow Rate:	1000 ml per minute at 4 ft. head
Type:	Peristaltic
Maximum Lift:	~20 feet
Battery:	Rechargeable 5 AH Gel Cell
Battery Life:	One Pump running: ~1 hour Two Pumps running: ~ ½ hour Standby: 3 months while still retaining power to run both pumps to capacity
Start Delay:	16 time settings from 0 to 12 hours
Composite Interval:	15 time settings from 5 min. to 12 hours plus an External Trigger mode setting
Sample Size:	15 composite sample sizes from 50ml to 2 liters plus a Full Bottle discrete setting (Approximate sizes at 4 foot head)
External Trigger Inputs:	250mS minimum pulse width Switch closure or 4-30VDC
Pulse Outputs:	5VDC one-second pulse 1000ohm output impedance
Bottle Switch Inputs:	Switch closure Input Floating read switch in bottle
Rain and Water Sensors:	Optional moisture sensors or switch closure inputs
Internal Fuse:	10A Slow-Blow

XII. Maintenance

Sampler

- a. The Global Water WS750 Water Sampler requires minimal maintenance. The sampler enclosure is rainproof and rugged. Avoid exposure to extremely rough usage. Routinely wipe the carrying case and control panel face, rinse the pickup hose and debris strainer, and wash the sample bottles with mild soap and warm water. Additional plastic and glass sample bottles, neoprene tubing for the sampler pump, bottle caps/float switches, removable debris strainers, and pickup hose can be purchased from Global Water (see Appendix C section).

Battery

- b. If the pump runs slowly, this is an indication that the battery requires recharging. Global Water recommends fully recharging batteries approximately once per month. In addition, the battery should be recharged before any extended use. NOTE: The battery life will last longer if recharged before it drains below 10.5 volts.
- c. To recharge the battery, disconnect the battery cable from the battery. Remove the battery from the enclosure. Attach the battery charger's spade lugs to the battery terminals, red lug to red terminal, and blue lug to black terminal. Plug the charger into a wall socket. A full recharge will take about 12 hours. Charging more than 24 hours may shorten the battery life. Additional batteries and battery chargers are available from Global Water (see Appendix C section).

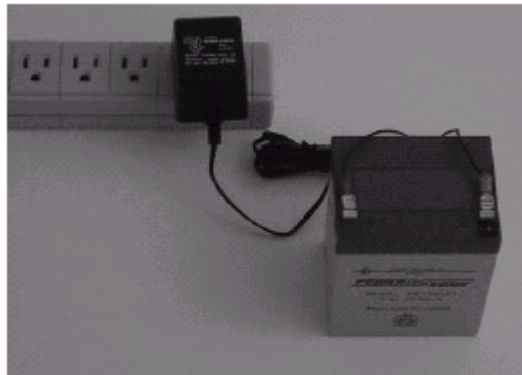

To recharge the battery, fasten the charger's disconnects onto the battery terminals and plug the charger into a wall socket.

XIII. Troubleshooting

- a. Check that the battery is firmly connected to the control panel and confirm that it is fully charged.
- b. Press the Pump Test buttons on the front panel. The test buttons should always run the pumps, regardless of the state of any of the inputs.
- c. Turn the power switch off for 1-2 seconds then back on to reset the sampler.
- d. Check the Status LED on the front panel.
 - i. The LED is off: If the water sensors are being used, check the Rain and Water Sensor inputs. Sensors must be in contact with moisture and unused inputs must have one of the shorting plugs supplied with the sampler plugged into the jack. If the Trigger Inputs are being used, confirm that External Trigger mode is selected on the Interval control. Check the pulses coming from the triggering device and confirm they meet specifications. Test the Trigger Inputs by plugging one of the shorting plugs supplied with the sampler into the jack.
 - ii. The LED is blinking: Check the Start Delay and Interval settings. The sampler may be waiting for the Delay timer to run out or it may be timing the interval between composite samples.
 - iii. The LED is on constantly: Check the bottle switches. The light remains on when both sample bottles are full or when both float switches are not plugged in or working properly. Plug one of the shorting plugs supplied with the sampler into one of the bottle switch jacks, the light should go out or start blinking.

Other issues

- e. Call us for tech support: 800-876-1172 or 916-638-3429 (many problems can be solved over the phone). Fax: 916-638-3270 or Email: globalw@globalw.com.

Be prepared to describe the problem being experienced including specific details of the application and installation and any additional pertinent information.

- f. In the event that the equipment needs to be returned to the factory for any reason, please call to obtain a RMA # (Return Material Authorization). Do not return items without a RMA # on the outside of the package.

Decontaminate the WS750 prior to returning.

Include a written statement describing the problems.

Send the package with shipping prepaid to Global Water's factory address. Insure the shipment, as the warranty does not cover damage incurred during transit.

- g. When calling for tech support, please have the following information ready;
1. Model #.
 2. Unit serial number.
 3. P.O.# the equipment was purchased on.
 4. Global Water's sales number or the invoice number.
 5. Repair instructions and/or specific problems relating to the product.

IXV. Warranty

- a. Global Water Instrumentation, Inc. warrants that its products are free from defects in material and workmanship under normal use and service for a period of one year from date of shipment from factory. Global Water's obligations under this warranty are limited to, at Global Water's option: (I) replacing or (II) repairing; any products determined to be defective. In no case shall Global Water's liability exceed the products original purchase price. This warranty does not apply to any equipment that has been repaired or altered, except by Global Water Instrumentation, Inc., or which has been subject to misuse, negligence or accident. It is expressly agreed that this warranty will be in lieu of all warranties of fitness and in lieu of the warranty of merchantability.
- b. The warranty begins on the date of the product's invoice.

Appendix A: Sample Size vs. Head Height

Use the following graph to see how sample size changes with head height. The Sample Size controls on the control panel are calibrated at a height of 4 feet. Increasing the head height decreases the sample size by a predictable amount. To determine the appropriate Sample Size setting for a desired volume; find the sample size on the horizontal axis, follow straight up to the line corresponding to your head height, then look across to the vertical axis and read the setting for the Size control on the control panel.

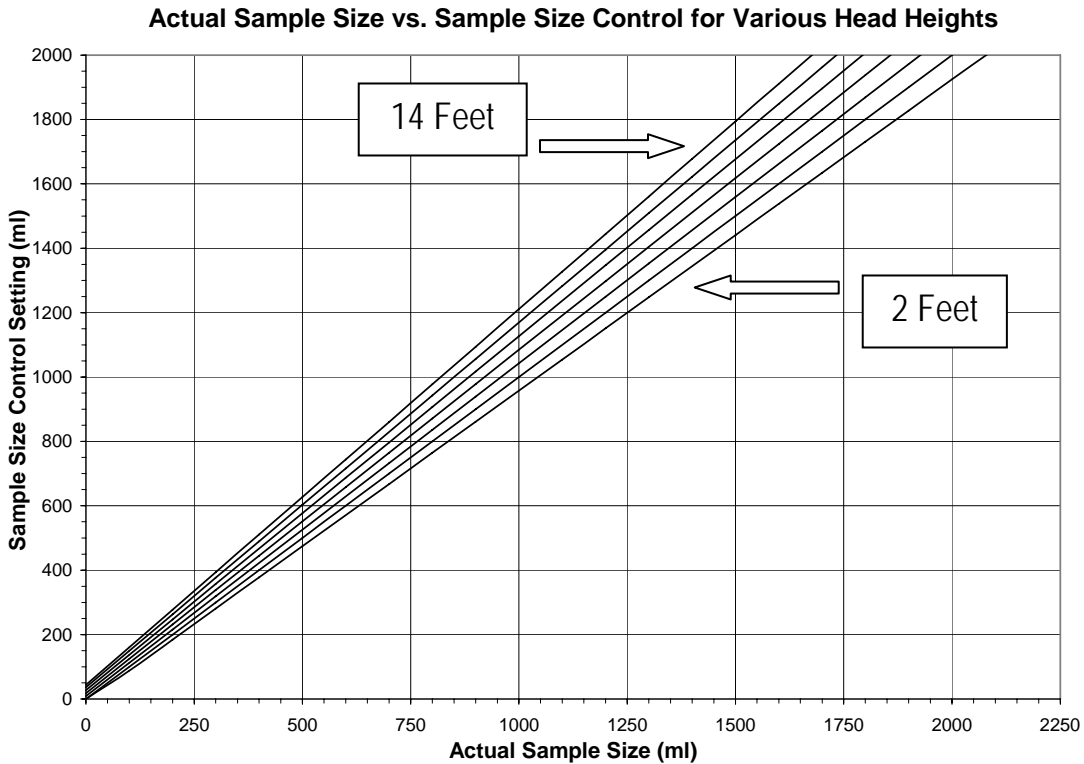

Appendix B: Battery Life

While battery life depends on several factors such as charge, condition and temperature; it can generally be assumed that the sampler can be deployed in the field for more than 3 months waiting to be triggered, while still retaining enough charge to run a single pump for one hour (about 10 gallons) or both pumps for ½ hour (5 gallons). To prevent large current surges which occur when the pumps first turn on, the WS750 is designed so that only one pump will turn on or off at a time. A ½ second time delay is inserted between these events, extending the life of the charge and the life of the battery.

Appendix C: Input and Output Connection

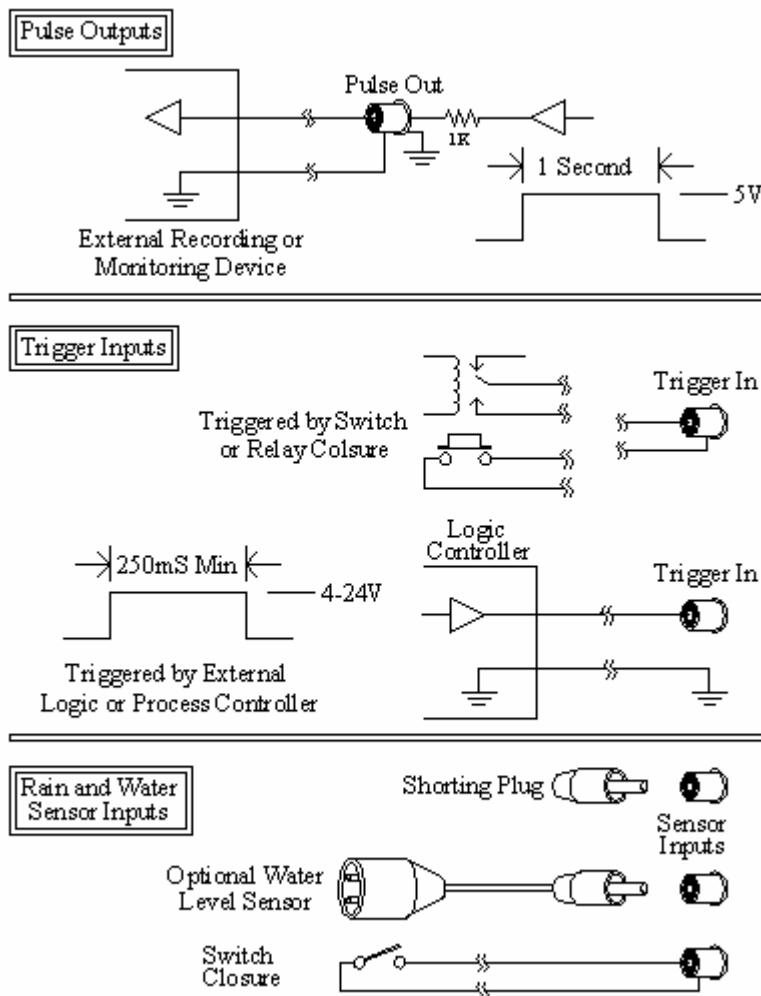

Phone 800-437-1146
Fax 425-861-7235
info@pollardwater.com

West Coast Branch
17515 NE 67th Ct
Redmond, WA 98052

East Coast Branch
200 Atlantic Ave
New Hyde Park, NY 11040

Appendix D: Accessories

<u>Part Description</u>	<u>Part Number</u>	<u>Unit</u>
12V 5Ah Battery	00-010	Each
Battery Charger	FE0400	Each
1 Gal Plastic Sample Bottle	00-418	Each
Bottle Cap/Float Switch	CB0200	Each
Pickup Hose	00-546	Feet
Pickup Strainer	CA0300	Each
Pump tubing	00-744	Feet
Rain and Water Sensors	CA0400	Each
Auto-Drain Rain Gauge	CH0000	Each