

Write the name and contact information of your Oakton distributor below.

## OPERATING INSTRUCTIONS

# OAKTON Model 35102-00 1/8 DIN pH 200 Controller

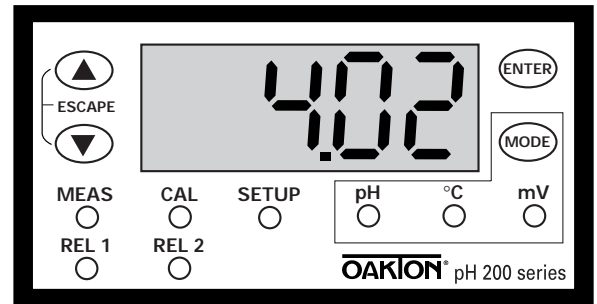

68X276102

R0 6/01

---

**OAKTON**<sup>®</sup>

---

**OAKTON**<sup>®</sup>

# Table of Contents

1. Introduction.....	4
2. Overview .....	5-11
2.1 Front panel .....	5
2.2 Back panel .....	6-7
2.3 Wiring .....	8-9
2.4 Panel-mounting the controller .....	10-11
3. Measurement Mode.....	12
4. Password .....	13
5. pH Calibration.....	14-15
6. ORP calibration .....	16
7. Temperature calibration.....	17
8. Setup Mode .....	18-29
<b>8.1 Setup mode overview.....</b>	<b>18-19</b>
<b>P1.0: Set point 1 .....</b>	<b>20-21</b>
P1.1: Select relay set point value.....	20
P1.2: Set relay as high or low set point .....	21
P1.3: Set hysteresis value.....	21
<b>P2.0: Set point 2 .....</b>	<b>22-23</b>
P2.1: Select relay set point value.....	22
P2.2: Set relay as high or low set point .....	23
P2.3: Set hysteresis value.....	23

<b>P3.0: Configuration .....</b>	<b>24-25</b>
P3.1: Select pH or ORP units .....	24
P3.2: Select symmetrical or asymmetrical input mode.....	25
P3.3: Select temperature compensation .....	25
<b>P4.0: Viewing calibration points: pH or ORP .....</b>	<b>26</b>
<b>P5.0: Viewing pH electrode data .....</b>	<b>27</b>
P5.1: View electrode offset .....	27
P5.2: View electrode slope.....	27
P5.3: View temperature probe offset .....	27
<b>P5.0: Viewing ORP electrode data .....</b>	<b>28</b>
P5.1: View electrode offset .....	28
P5.2: View temperature probe offset .....	28
<b>P6.0: Controller reset.....</b>	<b>29</b>
9. Specifications.....	30
10. Transmitter function .....	30
11. Specifications.....	31
12. Accessories .....	32-33
Appendix 1. Symmetrical mode .....	34-35
Appendix 2. External relays.....	36
Appendix 3. Factory defaults .....	37
13. Warranty .....	38
14. Return of Goods .....	38

# 1. Introduction

Thank you for purchasing a pH 200 ½ DIN pH/ORP Controller. This controller is a member of the line of quality process controllers available from OAKTON Instruments. These sturdy, economical pH/ORP controllers are designed with the features and reliability of a much more expensive instrument.

Your controller includes:

- removable terminal blocks for easy connections
- two mounting brackets for easy panel mounting
- a preinstalled wire jumper to preset the instrument for two wire Pt 100 operation.

When shipped, the controller is set to the pH mode. See Setup program P3.1 on page 24 for directions on selecting ORP mode.

Some of the features of this controller are:

- Two set point, two SPDT relay operation
- Scrolling, 14-segment LED guides user easily through setup functions
- Reliable power supply from 85 to 250 V AC/DC withstands voltage fluctuations
- All-push button operation from the front panel
- Two-point pH calibration, offset temperature and ORP calibration
- Adjustable hysteresis band prevents rapid contact switching near set-point
- Selectable automatic or manual temperature compensation
- Two level password protection
- Removable terminal strips for quick and easy connections
- Built-in memory backup retains setup even if power fails, and lets you configure unit before installation
- 4-20 mA output for remote monitoring or hard copy recording

# 2. Overview

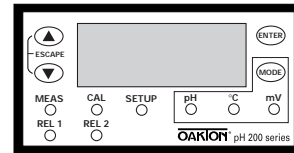

## 2.1 Front Panel

The front panel consists of a 4-digit LED display, 8 LED annunciators and 4 keys. See diagram above.

### Annunciators

<b>MEAS</b>	Displayed in measurement mode
<b>CAL</b>	Displayed in calibration mode
<b>SETUP</b>	Displayed in setup mode
<b>pH, °C, mV</b>	Units of the displayed parameter
<b>REL 1</b>	Displayed when Relay 1 is activated
<b>REL 2</b>	Displayed when Relay 2 is activated

### Keys

<b>▲ (Up/Increment)</b>	Use during calibration and setup modes to increment
<b>▼ (Down/Decrement)</b>	Use during calibration and setup modes to decrement
<b>MODE</b>	Use to toggle between measurement modes (pH/ORP and temperature)
<b>ENTER</b>	Press to confirm changes or to enter into further levels of the lower menu.
<b>▲ + ▼ together</b>	Escape to Measurement mode.

## 2.2 Back Panel

The back panel consists of four different connectors that can be used with removable terminal blocks (included):

- A. BNC connector (for pH or ORP electrode)
- B. 7 pin connector (for temperature sensor)
- C. 9 pin connector (for relays)
- D. 3 pin connector (for power supply)

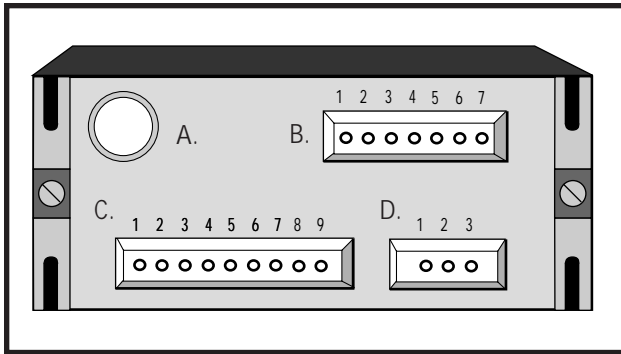

**CAUTION:** Electrical shock hazard! Make sure to remove AC power to the controller before wiring input and output connections.

B. The connection for the 7-pin connector are (from the left to right):

- 1. unused
- 2. unused
- 3. unused
- 4. unused
- 5. Pt 100 connection: ground (red or white)\*
- 6. Pt 100 connection: input (red or white)\*
- 7. Pt 100 connection: sense (jumper to terminal 6 if using 2-wire RTD)

\*If using an Oakton pH electrode with Pt 100 temperature element.

C. The connections for the 9-pin connector are (from left to right):

- 1. 4-20 mA connection, positive
- 2. 4-20 mA connection, negative
- 3. Relay 1 activated position (normally open)
- 4. Relay 1 center pole
- 5. Relay 1 deactivated position (normally closed)
- 6. Relay 2 activated position (normally open)
- 7. Relay 2 center pole
- 8. Relay 2 deactivated position (normally closed)
- 9. Liquid ground

D. The connections for the 3-pin connector are (from left to right):

- 1. VAC protective ground wire
- 2. VAC neutral wire
- 3. VAC live wire

## 2.3 Wiring

1. Connect the power supply to the three-pin terminal block (D):

- VAC protective ground wire = 1
- VAC neutral wire = 2
- VAC live wire = 3

This controller can accept voltages from 85 to 250 VAC/DC, 50/60 Hz.

2. Connect the Pt 100 leads to terminals 5 and 6 of the seven-pin terminal block (B). Either wire can be connected to either terminal. Terminals 6 and 7 must be shunted unless using a 3-wire RTD.

NOTE: pH 200 is factory set for manual temperature compensation. To select ATC, see page 25.

3. Slide the BNC connector of the pH (ORP) probe to the BNC connector on the back of the controller. Turn the notches of the connector until they lock into place.

4. Power on the controller. The display automatically shows the pH (ORP) reading, and the pH (ORP) annunciator lights.

NOTE: If the Pt 100 temperature probe is not connected or is broken and automatic temperature compensation is turned on, the display flashes to alert you.

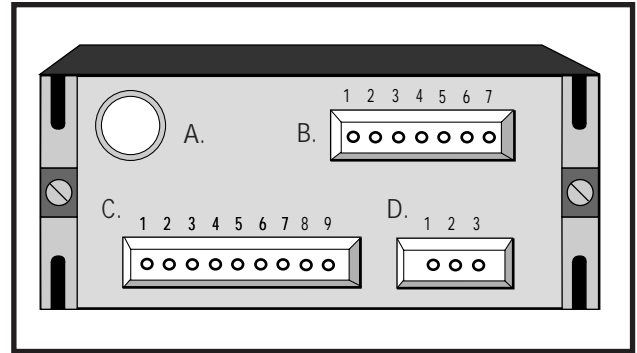

**CAUTION:** Electrical shock hazard! Make sure to remove AC power to the controller before wiring input and output connections, and before opening the controller housing.

## 2.4 Panel-mounting the controller

The supplied mounting hardware allows surface mounting to all panels and protective enclosures. Mounting cut-out size is 91 x 45 mm.

To attach the mounting to the controller:

1. Align the hole on the mounting bracket to the nut enclosed inside the controller (see "Back view" diagram below).
2. Insert the bolt through the hole in the bracket and screw into the nut inside the controller. Tighten the bolt until the front of the bracket holds firmly against the back of the panel or protective housing (see "Side views" diagram on page 11). Repeat on the other side.

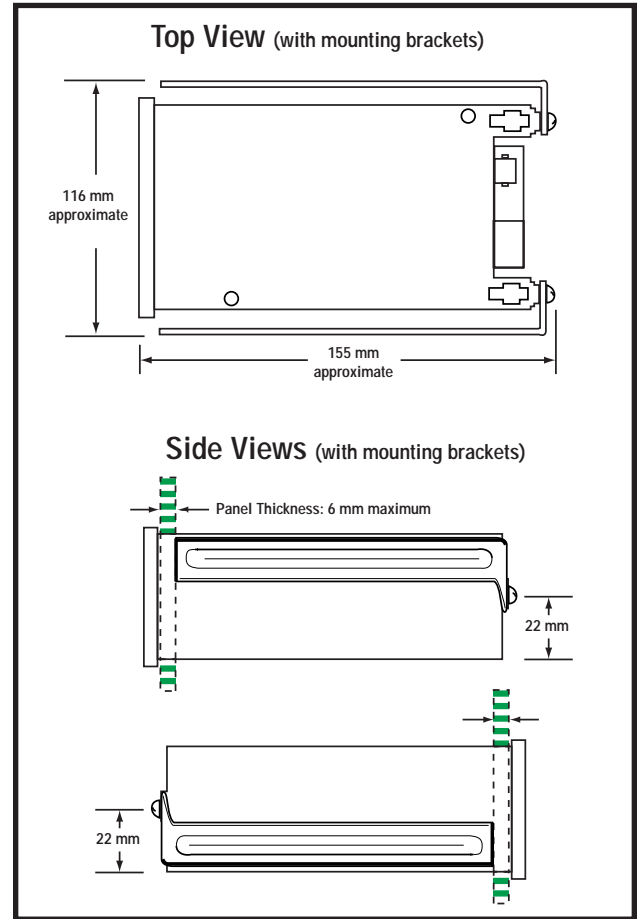
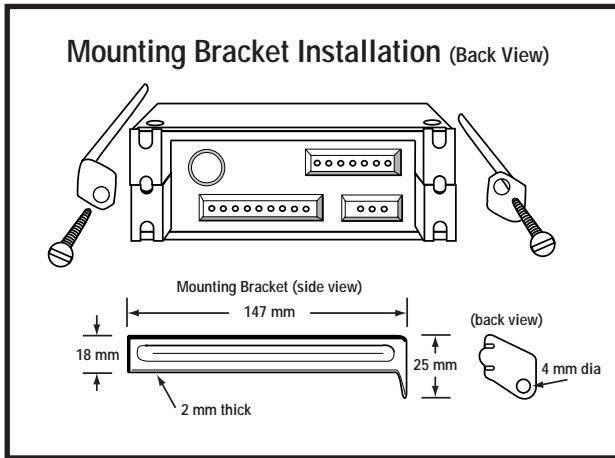

### 3. Measurement Mode

Press MODE to toggle between:

- pH (or ORP) measurement mode
  - Temperature measurement mode
- See *diagram at right*.

#### pH (ORP) measurement mode

The controller starts up in mode active when last powered off. The appropriate annunciator lights.

NOTE: Select pH or ORP measurement mode in Setup program P3.1. See page 24 for directions.

#### Temperature measurement mode

Press MODE key once to view the temperature measurement. The display shows ATC (automatic temperature compensation) or MTC (manual temperature compensation), then the current measured temperature. The °C annunciator lights when you are measuring temperature.

See Setup program P3.3 on page 25 for directions on selecting ATC or MTC.

See page 17 for directions on calibrating temperature readings.

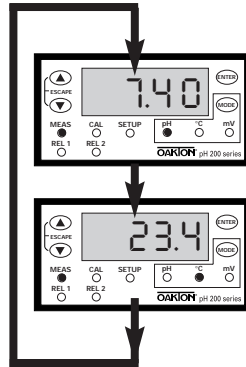

Pressing the MODE key toggles you between (from top to bottom)

- pH (or ORP) and
- Temperature

### 4. Password

To access Calibration and Setup functions, you need to enter a password code. You cannot change calibration and setup parameters unless you first enter the password.

This controller features two separate passwords:

- pH (ORP) calibration mode password = 011.
- Setup program password = 022.

To enter the password:

1. Press ENTER twice. The display reads "P.000". The first "0" is flashing.
2. Press ENTER again to leave the first digit "0" and to scroll to the next number.
3. Press the ▲ and ▼ keys to change the second digit to the correct number (1 or 2). Press ENTER.
4. Press the ▲ and ▼ keys to change the third digit to the correct number (1 or 2). Press ENTER.

If you enter an incorrect digit, press MODE to back up.

5. Press ENTER again. You are now in Calibration mode or Setup mode, depending on password entered.

See pages 14-17 for calibration instructions. See pages 18-29 for Setup program instructions.

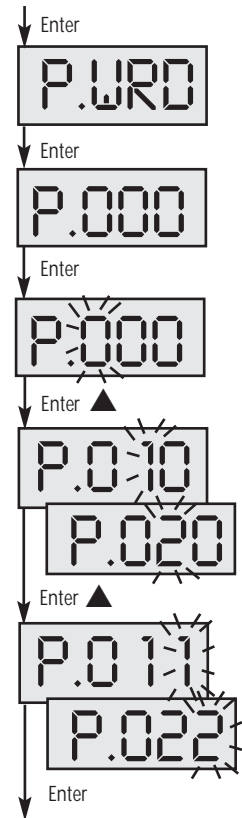

## 5. pH Calibration

This unit features seven preset buffer values (pH 1.68, 4.01, 6.86, 7.00, 9.18, 10.01, 12.45) for fast auto-calibration at one or two points. **The first calibration point must be pH 6.86 or 7.00.** When you calibrate this instrument, you need to use standard pH buffer solution that matches these values.

NOTE: If you are in ORP mode, see page 24 for directions on switching to pH mode.

1. Key in the password "011" using the method described in Section 4 (pg 13).
2. The display scrolls **BUFF.** and either buffer pH 7.00 or 6.86. You must calibrate at one of these two buffers for the first calibration. Use the ▲/▼ keys to select pH 7.00 or 6.86.
3. Make sure the electrode is in your buffer solution. In ATC mode, you must also immerse the temperature sensor in the buffer solution. In the symmetrically high-resistance measurement mode, you must also immerse the solution ground (potential equalization pin) in the buffer.
4. Allow the electrode time to stabilize.
5. Press ENTER. The instrument will blink with the uncalibrated pH value corresponding to the mV output of your pH probe.
6. Press ENTER to confirm the buffer value. The display blinks the calibrated value twice, shows "DONE" and moves to the next buffer.

NOTE: Buffer must be within  $\pm 1.5$  pH of the value you are calibrating to, or ERR1 will display. To clear the ERR1 display and return to calibration mode, press ▲/▼ together.



7. If you are performing 1-point calibration, press ▲/▼ together to return to measurement mode. If you are performing two point calibration, go to step 8.
8. Use the ▲/▼ keys to select the next buffer value (pH 1.68, 4.01, 9.18, 10.01, 12.45).
9. Make sure the electrode is in the correct buffer solution. Allow the electrode time to stabilize.
10. Press ENTER. The instrument will blink with the uncalibrated pH value corresponding to the mV output of your pH probe.
11. Press ENTER to confirm the buffer value. The display blinks the calibrated value twice and flashes "DONE". Press ENTER again to return to measurement mode.

NOTE: Buffer must be within  $\pm 1.0$  pH of the value you are calibrating to, or ERR1 will display. To clear the ERR1 display and return to calibration mode, press ▲/▼ together.

### Notes:

You can view the pH calibration points in the Setup program. See Setup program 5.0 on page 27.

The slope and offset are re-determined after each calibration.

If the value displayed in steps 5 and 10 differ substantially from the buffer value, this indicates electrode drift. Consider replacing your electrode.

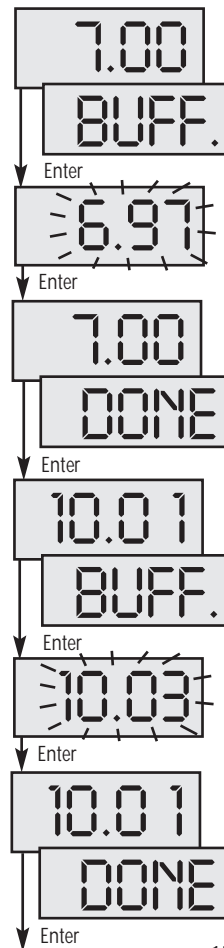

## 6. ORP Calibration

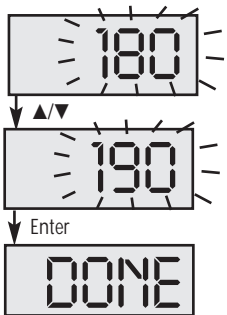

You can offset mV (ORP) value up to  $\pm 150$  mV to agree with a calibration solution or an established work standard.

**NOTE:** If you are in pH mode, see page 24 for directions on switching to ORP mode.

1. Key in the password "011" using the method described in section 4 (pg 13).
2. The instrument will blink with the uncalibrated mV output of your electrode.
3. Determine the mV value of your solution with a meter known to be accurate.
4. Press the  $\blacktriangle$  and  $\blacktriangledown$  keys to offset the mV value on the controller display to match the value of the solution you are measuring.
5. Press ENTER. The display flashes "DONE". Press ENTER again to return to measurement mode.

### Notes:

You can view the mV offset in the Setup program. See Setup mode P5.0 on page 28.

## 7. Temperature Calibration

This controller features selectable automatic temperature compensation (ATC) or manual temperature compensation (MTC).

**ATC:** ATC readings require a Pt 100 temperature element. ATC automatically compensates for temperature fluctuations. You can offset your ATC temperature reading by  $\pm 10^{\circ}\text{C}$ .

**Important:** If there is no temperature element wired into the controller and ATC is selected on, the screen will flash in pH or ORP mode, and you will see an error message (OR) in temperature mode.

**MTC:** MTC lets you select a specific value at which temperature will be compensated. You can select a manual temperature value from  $-10$  to  $110^{\circ}\text{C}$ . Factory default is  $25.0^{\circ}\text{C}$ .

See Setup program P3.3, page 25, for directions to select ATC or MTC.

To offset temperature:

1. Press MODE to select  $^{\circ}\text{C}$  mode. The display shows MTC or ATC, then the temperature.
2. Key in the password "011" using the method described in section 4 (pg 13).
3. The screen will flash the current  $^{\circ}\text{C}$  reading.
4. **For ATC:** Determine the temperature of your solution with a meter known to be accurate. Press the  $\blacktriangle$  and  $\blacktriangledown$  keys to offset the  $^{\circ}\text{C}$  value on the controller display to match the value of the solution you are measuring.

**For MTC:** Press the  $\blacktriangle$  and  $\blacktriangledown$  keys to offset the  $^{\circ}\text{C}$  value on the controller display to match the desired value.

5. Press ENTER. The display flashes "DONE". Press ENTER again to return to measurement mode.

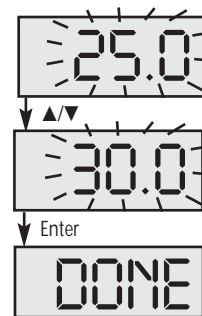

## 8. Setup Mode

### 8.1. General information

**IMPORTANT:** When Setup mode is entered, the 4-20 mA output freezes and the relay de-activates (if it was in an activated condition).

#### To enter setup mode:

1. Key in the password "022" using the method described in section 4 (pg 13).
2. Press the ▲ or ▼ keys to display the various sub-menus shown at below and at right.
3. When a sub-menu item is displayed, press the ENTER key to enter that sub-menu.
5. Press ▲/▼ together (ESCAPE) to leave Setup mode.

#### Setup mode overview



**P1.0: Set Point 1** pages 20-21  
**P1.1:** select relay 1 set point value  
**P1.2:** select relay 1 as low or high set point  
**P1.3:** set relay 1 hysteresis value



**P2.0: Set Point 2** pages 22-23  
**P2.1:** select relay 2 set point value  
**P2.2:** select relay 2 as low or high set point  
**P2.3:** set relay 2 hysteresis value

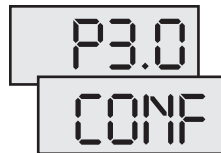

**P3.0: Configuration** pages 24-25  
**P3.1:** select pH or ORP units  
**P3.2:** select symmetrical or asymmetrical input mode  
**P3.3:** select temperature compensation (MTC or ATC)

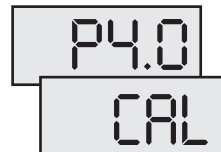

**P4.0: Calibration data** page 26  
**P4.1:** view first calibration point  
**P4.2:** view second calibration point (pH only)

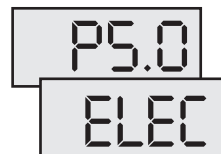

**P5.0: Electrode data** pages 27-28  
**P5.1:** view electrode offset  
**P5.2:** view electrode slope (view in pH mode only)  
**P5.3:** view temperature probe offset (view in ATC mode only)

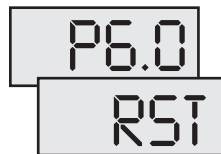

**P6.0: Controller reset** page 29  
**P6.1:** clear calibration data and revert to factory default settings

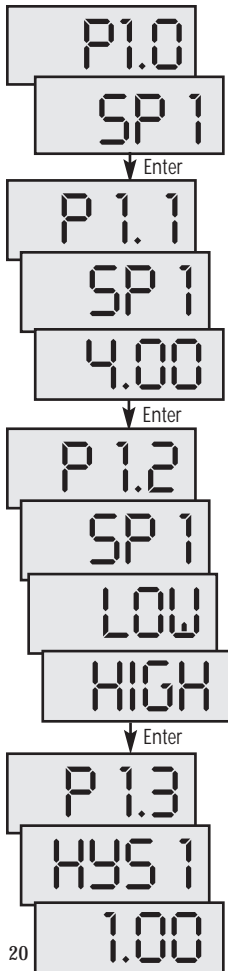

## P1.0: Set Point 1

Setup program P1.0 lets you set parameters for relay 1.

**P1.1: select relay set point value**

**P1.2: select relay as low or high set point**

**P1.3: set hysteresis value (dead band)**

Press ▲/▼ together at anytime to return to measurement mode.

### P1.1: select relay set point value

This lets you choose the pH (or ORP) value that will cause your controller to activate. If this value is crossed, the set point relay 1 LED will light.

1. Key in the password “022” using the method described in section 4 (pg 13).
2. The screen will scroll P1.0 and SP1. Press ENTER.
3. The screen will scroll P1.1, SP1, then the current set point value.
4. Press the ▲ and ▼ keys to adjust the first relay set point. You can adjust it in 0.01 increments from 0.00 to 14.00 pH (-999 to 1000 mV).
5. Press ENTER to confirm and move step 3 of P1.2.

### P1.2: set relay as high or low set point

Select a low set point to activate controller when your value undershoots the set point; select a high set point to activate controller when your value overshoots the set point.

Using both SP1 and SP2, you can select lo/lo, lo/hi, hi/lo, or hi/hi set points.

1. Key in the password “022” using the method described in section 4 (pg 13).
2. The screen will scroll P1.0 and SP1. Press ENTER twice.
3. The screen will scroll P1.2, SP1, and LOW (or HIGH).
4. Press the ▲ and ▼ keys to toggle between LOW and HIGH.
5. Press ENTER to confirm and move to step 3 of P1.3.

### P1.3: Set hysteresis value

Hysteresis prevents rapid contact switching if your value is fluctuating near the set point. Once activated, the relay will not return to resting position until the measured value has passed through the set point plus hysteresis value.

Example: With a low set point of 4.00 and a hysteresis value of 0.5, the relay will activate at pH values below 4.00, but will not return to resting until the pH rises above pH 4.50.

You can set the hysteresis value from:

- pH mode: 0.00 to 2.00 pH
- ORP mode: 0 to 300 mV

1. Key in the password “022” using the method described in section 4 (pg 13).
2. The screen will scroll P1.0 and SP1. Press ENTER three times.
3. The screen will scroll P1.3, HYS1, and the current hysteresis value.
4. Press the ▲ and ▼ keys to adjust the hysteresis value.
5. Press ENTER to confirm and return to general Setup mode. Press ▲/▼ together to return to measurement mode.

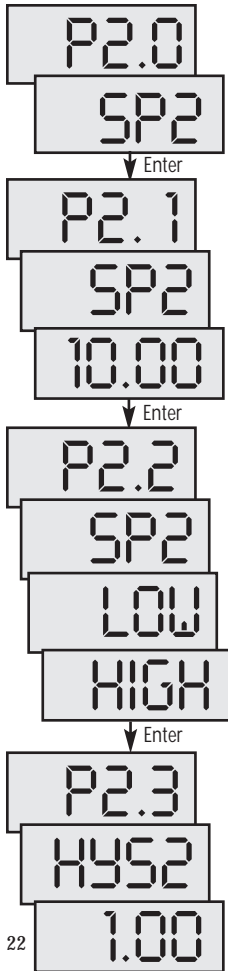

## P2.0: Set Point 2

Setup program P2.0 lets you set parameters for relay 2.

**P2.1: select relay set point value**

**P2.2: select relay as low or high set point**

**P2.3: set hysteresis value (dead band)**

Press ▲/▼ together at anytime to return to measurement mode.

### P2.1: select relay set point value

This lets you choose the pH (or ORP) value that will cause your controller to activate. If this value is crossed, the set point relay 2 LED will light.

1. Key in the password “022” using the method described in section 4 (pg 13).
2. Press the ▲ key once. The screen will scroll P2.0 and SP2. Press ENTER.
3. The screen will scroll P2.1, SP2, then the current set point value.
4. Press the ▲ and ▼ keys to adjust the first relay set point. You can adjust it in 0.01 increments from 0.00 to 14.00 pH (-999 to 1000 mV).
5. Press ENTER to confirm and move step 3 of P2.2.

### P2.2: set relay as high or low set point

Select a low set point to activate controller when your value undershoots the set point; select a high set point to activate controller when your value overshoots the set point.

Using both SP1 and SP2, you can select lo/lo, lo/hi, hi/lo, or hi/hi set points.

1. Key in the password “022” using the method described in section 4 (pg 13).
2. Press the ▲ key once. The screen will scroll P2.0 and SP2. Press ENTER twice.
3. The screen will scroll P2.2, SP2, and LOW (or HIGH).
4. Press the ▲ and ▼ keys to toggle between LOW and HIGH.
5. Press ENTER to confirm and move to step 3 of P2.3.

### P2.3: Set hysteresis value

Hysteresis prevents rapid contact switching if your value is fluctuating near the set point. Once activated, the relay will not return to resting position until the measured value has passed through the set point plus hysteresis value.

Example: With a high set point of 10.00 and a hysteresis value of 0.5, the relay will activate at pH values above 10.00, but will not return to resting until the pH falls below pH 9.50.

You can set the hysteresis value from:

- pH mode: 0.00 to 2.00 pH
- ORP mode: 0 to 300 mV

1. Key in the password “022” using the method described in section 4 (pg 13).
2. Press the ▲ key once. The screen will scroll P2.0 and SP2. Press ENTER three times.
3. The screen will scroll P2.3, HYS2 and the current hysteresis value.
4. Press the ▲ and ▼ keys to adjust the hysteresis value.
5. Press ENTER to confirm and return to general Setup mode. Press ▲/▼ together to return to measurement mode.

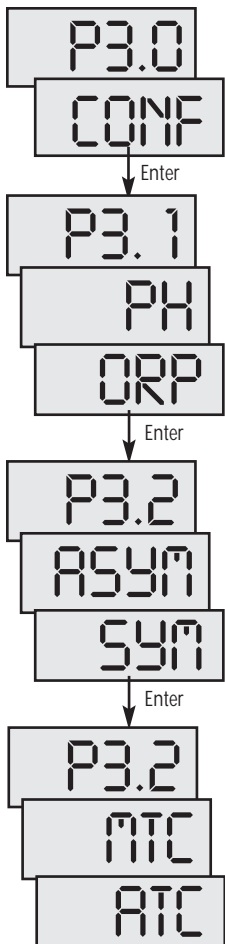

## P3.0: Configuration

Setup program P3.0 lets you configure controller parameters.

**P3.1: select pH or ORP units**

**P3.2: select symmetrical or asymmetrical input mode**

**P3.3: select temperature compensation (manual or automatic)**

Press ▲/▼ together at any time to return to measurement mode.

### P3.1: Select pH or ORP units

This lets you set the controller to take pH or ORP measurements.

1. Key in the password “022” using the method described in section 4 (pg 13).
2. Press the ▲ key twice. The screen will scroll P3.0 and CONF. Press ENTER.
3. The screen will scroll P3.1 and PH (or ORP).
4. Press the ▲ and ▼ keys to toggle between pH and ORP units.
5. Press ENTER to confirm and move step 3 of P3.2.

### P3.2: select symmetrical or asymmetrical input mode

Use asymmetrical mode under normal operating conditions. Use symmetrical mode when the measuring environment is electrically noisy (i.e. in electroplating environments). Default is asymmetrical.

See Appendix 1 on pages 34-35 for more details on operation in symmetrical and asymmetrical modes.

1. Key in the password “022” using the method described in section 4 (pg 13).
2. Press the ▲ key twice. The screen will scroll P3.0 and CONF. Press ENTER twice.
3. The screen will scroll P3.2 and ASYM (or SYM).
4. Press the ▲ and ▼ keys to toggle between ASYM and SYM.
5. Press ENTER to confirm and move to step 3 of P3.3.

### P3.3: Select temperature compensation

This controller features selectable automatic temperature compensation (ATC) or manual temperature compensation (MTC). ATC automatically compensates for temperature fluctuations; MTC lets you select a specific value at which temperature will be compensated. ATC readings require a temperature sensor.

1. Key in the password “022” using the method described in section 4 (pg 13).
2. Press the ▲ key twice. The screen will scroll P3.0 and CONF. Press ENTER three times.
3. The screen will scroll P3.3 and MTC (or ATC).
4. Press the ▲ and ▼ keys to toggle between MTC and ATC.
5. Press ENTER to confirm and return to general Setup mode. Press ▲/▼ together to return to measurement mode.

NOTE: ORP is not affected by temperature and so ATC does not operate in ORP mode. When set for ATC, the pH 200 will display temperature if a 100 Ω Pt 100 sensor is connected.

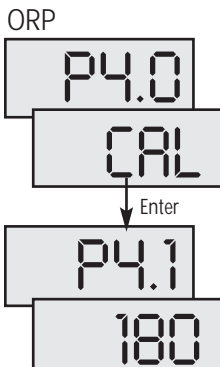
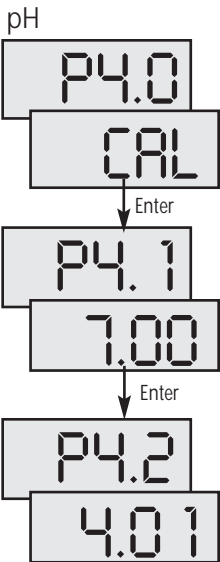

## P4.0: Viewing calibration points: pH or ORP

Setup program P4.0 lets you view the current points at which the controller is calibrated. This is a “view only” parameter.

### P4.1: first calibration point

### P4.2: second calibration point (pH only)

When the controller has no calibration points in memory, the display will show “----”.

Press ▲/▼ together at any time to return to measurement mode.

## P4.0: Viewing calibration points

1. Key in the password “022” using the method described in section 4 (pg 13).
2. Press the ▲ key three times. The screen will scroll P4.0 and CAL. Press ENTER.
3. The screen will scroll P4.1, then CAL, then the first calibration point.
4. Press ENTER.  
**In pH mode**, the screen will display P4.2, then CAL, then the second calibration point.  
**In ORP mode**, the screen returns to the general Setup menu.
5. If you are in pH mode, press ENTER again to confirm and return to general Setup mode. Press ▲/▼ together to return to measurement mode.

## P5.0: Viewing pH electrode data

In pH mode, Program 5 has three “view only” options that lets you check the electrode parameters for diagnostic purposes.

### P5.1: view pH electrode offset

### P5.2: view pH electrode slope

### P5.3: view temperature probe offset

(available only when ATC is selected on in parameter P3.3, page 25)

These parameters will change each time you recalibrate the controller.

Press ▲/▼ together at any time to return to measurement mode.

## P5.0: Viewing pH electrode data

1. Key in the password “022” using the method described in section 4 (pg 13).
2. Press the ▲ key four times. The screen will scroll P5.0 and ELEC. Press ENTER.
3. The screen will scroll P5.1, then P.OFS, then the pH electrode offset in mV at the pH 6.86/7.00 calibration point.
4. Press ENTER. The screen will display P5.2, then SLPE, then the electrode slope in mV.
5. **MTC on:** press ENTER to return to general Setup mode.  
**ATC on:** go to step 6.
6. The screen will scroll P5.3, then T.OFS, then the temperature offset value.
7. Press ENTER to return to general Setup mode. Press ▲/▼ together to return to measurement mode.

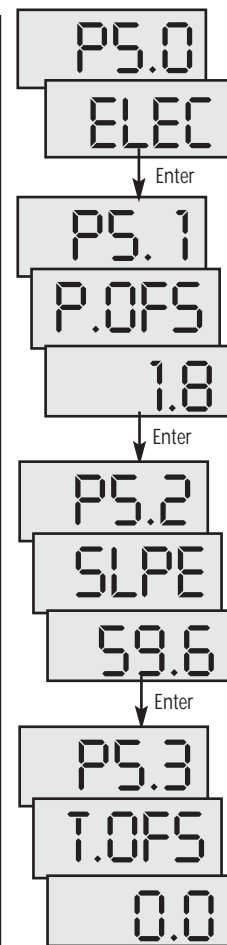

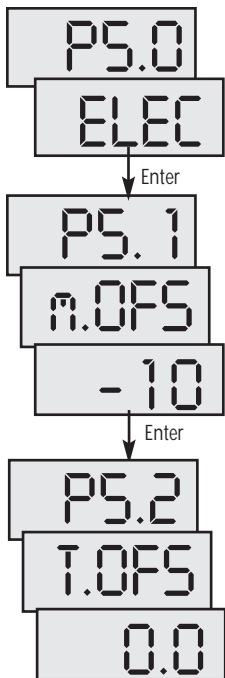

## P5.0: Viewing ORP electrode data

In ORP mode, Program 5 has two “view only” options that lets you check the electrode parameters for diagnostic purposes.

### P5.1: view ORP electrode offset

**P5.2: view temperature probe offset**  
(available only when ATC is selected on in parameter P3.3, page 25)

These parameters will change each time you recalibrate the controller.

Press ▲/▼ together at any time to return to measurement mode.

### P5.0: Viewing ORP electrode data

1. Key in the password “022” using the method described in section 4 (pg 13).
2. Press the ▲ key four times. The screen will scroll P5.0 and ELEC. Press ENTER.
3. The screen will scroll P5.1, then m.OFS, then the ORP electrode offset at the point of calibration.
4. **MTC on:** press ENTER to return to general Setup mode.  
**ATC on:** go to step 5.
5. The screen will scroll P5.2, then T.OFS, then the temperature offset value.
6. Press ENTER to return to general Setup mode. Press ▲/▼ together to return to measurement mode.

## P6.0: Controller reset

This parameter lets you reset controller. All pH and ORP calibration data will be cleared, and all Setup parameters revert to factory default values. Temperature mode (ATC or MTC) and calibration data remains unchanged.

See page 37 for a table of factory default values.

Press ▲/▼ together at any time to return to measurement mode.

### P6.0: Controller reset

1. Key in the password “022” using the method described in section 4 (pg 13).
2. Press the ▲ key five times. The screen will scroll P6.0 and RST. Press ENTER.
3. The screen will scroll P6.1, then NO.
4. Press the ▲ and ▼ keys to toggle between YES and NO. Pressing YES will clear all calibration data and setup parameters!
7. Press ENTER to confirm selection and return to general Setup mode. Press ▲/▼ together to return to measurement mode.

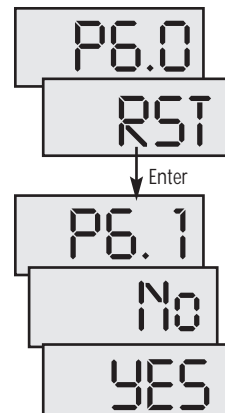

## 9. Relays

This controller features two SPDT nonpowered relays; rated for 6A at 110 VAC, 250 VAC maximum. When your process exceeds the set parameters of a relay set point, the REL 1 or REL 2 indicator lights. You can also use one relay to operate an alarm.

To set parameters for relay one and relay two, see Setup programs P1.0 and P2.0 on pages 20-23.

For relay wiring diagrams, see pages 6-9.

## 10. Transmitter Function

You can connect a 4-20 mA current loop if remote data logging is required. The current will be proportional to the pH (or ORP) displayed on the panel display.

**pH:** 0.00 pH = 4 mA; 14.00 pH = 20 mA

**ORP:** -999 mV = 4 mA; 1000 mV = 20 mA

The 4-20 mA current loop can drive a load resistance of no more than 200  $\Omega$ . See the wiring diagram on pages 8-9 for information on how to hook up your transmitter to the controller.

## 11. Specifications

	Range	Resolution	Accuracy
<b>pH</b>	0.00 to 14.00 pH	0.01 pH	$\pm 0.01$ pH
<b>mV</b>	-999 to 1000 mV	1 mV	$\pm 2.0$ mV
<b>°C</b>	-10.0 to 110.0°C	0.1°C	$\pm 0.5$ °C

**Control type:** on/off

**Number of inputs:** one

**Number of set points:** two (hi/hi, lo/lo, hi/lo, or lo/hi)

**Hysteresis (dead band):** adjustable; 0.0 pH to 2.0 pH or 0 to 300 mV

**Output:**

**Control:** 2 SPDT nonpowered relays; 6A @ 110 VAC, 250 VAC max

**Current:** 4 to 20 mA output, isolated

4 mA = 0.00 pH or -999 mV; 20 mA = 14.00 pH or 1000 mV

**Calibration:**

pH: one or two points (pH 1.68, 4.01, 6.86, 7.00, 9.18, 10.01, 12.45).

First point must be pH 6.86 or 7.00

mV:  $\pm 150$  mV offset

Temperature:  $\pm 10.0$ °C offset

**Temperature compensation:** Automatic or manual, from 0 to 100°C

**pH slope range:** 80% to 110%

**Input impedance:** 10<sup>12</sup>

**Password protection:** two level (calibration and setup parameters)

**Display:** LED, four digit, 14-segment

**Power:** 85 to 250 VAC/DC, 50/60 Hz

**Operating temperature:** 0 to 50°C, 10 to 95% RH

**Connectors:**

pH/ORP: BNC plug (asymmetric or symmetric)

Temperature: 2 or 3 wire 100  $\Omega$  Pt RTD

**Dimensions (mm):** 1/8 DIN (48 x 96 x 150); panel mount 91 x 45

## 12. Accessories

### Extra controllers

**35102-00 pH 200 controller.** Includes mounting hardware and terminal blocks

**35100-90 Power cord;** 3 ft with bare leads, 3 prong U.S. plug, 110 VAC

### Semi-domed pH electrodes

These double-junction electrodes feature a unique surface design that provides protection from particulates while increasing flow across the junction to provide cleaning. Ceramic junction provides toughness along with steady electrolyte flow. The graphite body probes act as a solution ground and take advantage of the controller's symmetrical mode (see pages 34-35 for more information). Sealed KCl/AgCl reference. Have 10-ft cable, BNC connector, and stripped ends for ATC element. Dimensions: 5.875"L

**35807-00 Semi-domed electrode,** epoxy body, 3/4" NPT thread

**35807-05 Semi-domed electrode,** epoxy body, 1" NPT thread

**35807-10 Semi-domed electrode,** graphite body, 3/4" NPT thread

**35807-15 Semi-domed electrode,** graphite body, 1" NPT thread

### In-line/submersible electrodes

These permanently encapsulated combination electrodes have a CPVC body and 3/8" NPT threads on both ends. Install in a tee fitting or on a submersion pipe for tank mounting. Sealed KCl/AgCl reference. Have 10-ft cable, BNC connector, and stripped ends for ATC element. Dimensions: 6.325"L x 1"OD

**35801-02 In-line/submersible pH electrode;** single junction

**35801-08 In-line/submersible pH electrode;** double junction

**35801-21 In-line/submersible ORP electrode;** double junction, Pt band sensor

### Submersible electrodes

These combination electrodes are permanently encapsulated in a 3-ft L x 1"OD ABS pipe—install in a tank. Sealed KCl/AgCl reference. Have 10-ft cable, BNC connector, and stripped ends for ATC element.

**35806-00 Submersible pH electrode;** single junction

**35806-01 Submersible pH electrode;** double junction

**35806-02 Submersible ORP electrode;** double junction, Pt band sensor

### pH buffer solutions

These buffer solutions are standardized to  $\pm 0.01$  pH at 25°C. They are labeled with pH vs. Temperature tables to adjust readings for accurate calibration. They are also labeled with the name and CAS number for all ingredients to conform to "Right-to-Know" requirements, and are supplied with an MSDS (Material Safety Data Sheet). Certified to NIST-traceable standards.

**00654-00 pH 4.01,** 1 pint bottle

**00654-04 pH 7.00,** 1 pint bottle

**00654-08 pH 10.00,** 1 pint bottle

## Appendix 1: Symmetrical mode

Your controller can operate in asymmetrical or symmetrical mode. See Setup program P3.2 on page 25 for information on selecting the appropriate mode.

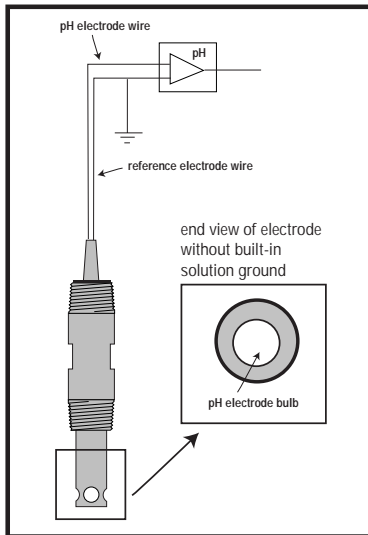

**Asymmetrical mode**

**Asymmetrical mode** works well in environments with where there is little or no electrical noise. When there is electrical noise, the noise acts as a common signal and is picked up by both the pH and the reference electrodes.

However, since the reference electrode is grounded to the ground potential of the amplifier, electrical noise will be present only on the pH electrode. This noise is amplified along with the pH signal, which causes reading fluctuations in an electrically noisy atmosphere. Electrical noise from a DC source (as in an electroplating tank) will typically result in stable but incorrect values.

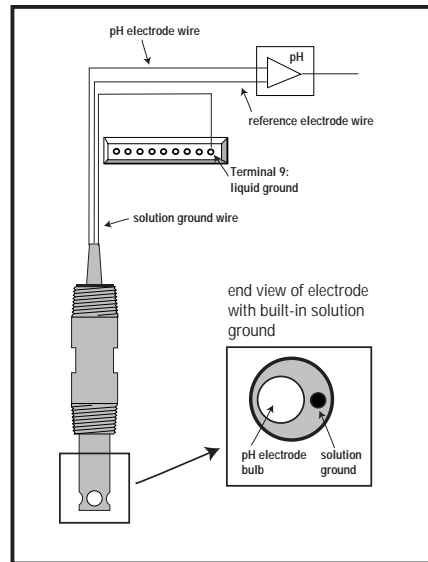

**Symmetrical mode**

**Symmetrical mode.** For noisy electrical environments, this controller offers Symmetrical Mode operation. To take advantage of Symmetrical operation, you must have an electrode with a solution ground (potential matching) pin. If your electrode does not have a solution ground, be sure to set the controller to Asymmetrical mode.

Symmetrical mode avoids grounding the reference electrode by reconfiguring the input to a floating differential mode (see diagram at right). The electrical noise appears equally on the pH and reference electrodes, and is therefore rejected by the operational amplifier.

Oakton offers electrodes with a potential matching pin. See our Accessories section on page 32.

## Appendix 2: External relays

### Using controller with external relays

The relays on the Oakton 200 series controller are rated for 6 amps at 110 VAC and can be wired directly to your final control element if its power draw does not exceed this. However, to preserve the life of your controller, or if higher power is needed, we recommend that you use the controller relay to drive an external relay.

The diagram below shows a typical installation. Wiring should be changed appropriately if normally closed operation is desired.

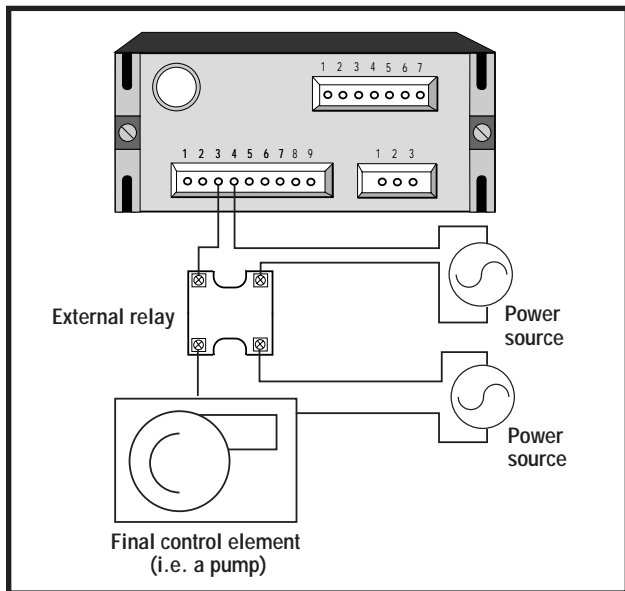

## Appendix 3: Factory defaults

Resetting the controller to factory default settings clears all calibration data and most other setup functions you might have changed. The following settings will remain as you have set them:

- Measurement mode (pH or ORP)
- Temperature compensation mode (ATC or MTC)
- The temperature offset calibration value if in ATC mode

To clear data, see Setup program P6.0 on page 29.

pH defaults	
pH input	asymmetrical
offset	0.0 mV
slope	59.2 mV
set point 1	pH 4.00 / LOW / hysteresis pH 1.00
set point 2	pH 10.0 / HIGH / hysteresis pH 1.00
mV defaults	
mV input	asymmetrical
offset	0.00 mV
Set point 1	-100 mV / LOW / hysteresis 5 mV
Set point 2	900 mV / HIGH / hysteresis 5 mV
Temperature defaults	
Temp. compensation mode	remains unchanged
MTC mode	Reset to 25°C if in MTC mode
ATC mode	remains at last calibration if in ATC mode

## 13. Warranty

Oakton Instruments warrants this product to be free from significant deviations in material and workmanship for a period of three years from the date of purchase. If repair is necessary and has not been the result of abuse or misuse within the warranty period, please return by freight pre-paid and amendment will be made without charge. The Customer Service Department will determine if the product problem is due to deviations or customer abuse. Out of warranty products will be repaired on a charge basis.

## 14. Return of Goods

Authorization must be obtained from our Customer Service Department before returning items for any reason. When applying for authorization, please include data regarding the reason the items are to be returned. For your protection, items must be carefully packed to prevent damage in shipment and insured against possible damage or loss. We will not be responsible for damage resulting from careless or insufficient packing. A restocking charge will be made on all unauthorized returns. NOTE: We reserve the right to make improvements in design, construction, and appearance of products without notice.