

Please read and save this Repair Parts Manual. Read this manual and the General Operating Instructions carefully before attempting to assemble, install, operate or maintain the product described. Protect yourself and others by observing all safety information. The Safety Instructions are contained in the General Operating Instructions. Failure to comply with the safety instructions accompanying this product could result in personal injury and/or property damage! Retain instructions for future reference.

High Head Centrifugal Pumps

Cast Iron, Bronze, and Stainless Steel Models

Refer to form 1808-634-00 for General Operating and Safety Instructions.

Description

These pumps are non self-priming units designed for use where higher heads are needed to handle liquid transfer, heating and cooling applications, where no suction lift is required. All models feature high-efficiency closed impellers and continuous duty, 3450 RPM, 56J frame motors. The discharge port on all models can be rotated in 90° increments to accommodate specific applications. Casing working pressure to 150 psi (1034 kPa). These are manual units, no controls are supplied. Single phase units are capacitor start and have automatic thermal protection. Check motor wiring before putting unit into operation (see motor nameplate for specific wiring diagrams). All units are for use with non-flammable, non-abrasive liquids, compatible with pump component materials

CAST IRON UNITS

Pump construction is cast iron casing and adapter. Cast 316 stainless steel impeller. Buna N type 21 mechanical shaft seal with carbon and ceramic wear faces. O-ring casing seal. Handles liquids from 40° to 180° F (4° to 82° C).

BRONZE UNITS

Pump construction is cast bronze casing and adapter. Cast 316 stainless steel impeller. Viton type 21 mechanical shaft seal with carbon and ceramic wear faces. O-ring casing seal. Handles liquids from 40° to 200° F (4° to 93° C).

316 STAINLESS STEEL UNITS

Pump construction is cast 316 stainless steel casing, adapter, and impeller. Viton type 21 mechanical shaft seal with carbon and ceramic wear faces. O-ring casing seal. Handles liquids from 40° to 200° F (4° to 93° C).

Dimensions (Inches)

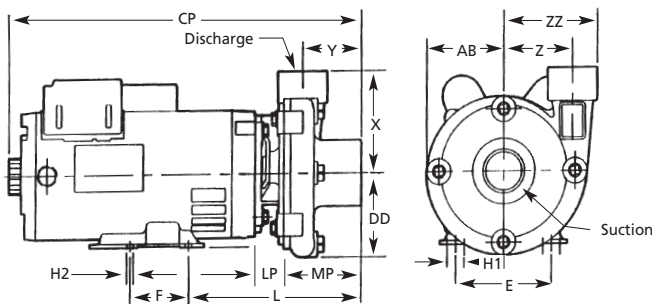

Figure 1 - Dimensions

Model	Suc.*	Dis.*	AB†	CP†	DD	E	F	H1	H2	L	LP	MP	X	Y	Z	ZZ
489 Series	1 1/4	1	3.55	13.00	3.72	4.88	3.00	0.88	0.34	8.22	2.03	2.83	4.79	2.15	3.35	4.42
490 Series	1 1/2	1 1/4	3.93	15.00	4.04	4.88	3.00	0.88	0.34	8.84	1.47	4.01	4.94	3.00	3.49	4.76

NOTE: Dimensions have a tolerance of $\pm 1/8$ "

(*) Standard NPT (female) pipe thread. (†) This dimension may vary due to motor manufacturer's specifications.

Maintenance

⚠ WARNING Make certain that the unit is disconnected from the power source before attempting to service or remove any components!

SHAFT SEAL REPLACEMENT

Refer to Figures No. 2 and 3.

REMOVAL OF OLD SEAL

IMPORTANT: Always replace both seal seat (Ref. No. 5) and seal head (Ref. No. 6) to insure proper mating of components! Also, impeller seal (Ref. No. 9) should be replaced anytime impeller fastener (Ref. No. 10) has been removed.

1. Remove fasteners (Ref. No. 3) connecting casing (Ref. No. 12) to adapter (Ref. No. 4).
2. Remove casing.

⚠ CAUTION Care should be taken not to pinch or "shave" casing seal (Ref. No. 11) between adapter and casing.

High Head Centrifugal Pumps

Cast Iron, Bronze, and Stainless Steel Models

Specifications

DRIVER			Power Supply @60 Hz	PUMP Suction x Discharge*	Weight (lbs.)		
Model	HP	Enclosure			Cast Iron	Bronze	SS
4893	1/2	ODP	115/230, 1 phase	1 1/4" x 1"	43 lbs.	44 lbs.	43 lbs.
4894	1/2	ODP	230/460, 3 phase	1 1/4 x 1	43	41	43
4895	3/4	ODP	115/230, 1 phase	1 1/4 x 1	44	45	44
489C	3/4	TEFC	115/230, 1 phase	1 1/4 x 1	46	49	46
4896	3/4	ODP	230/460, 3 phase	1 1/4 x 1	44	42	44
489D	3/4	TEFC	230/460, 3 phase	1 1/4 x 1	44	47	44
4890	1	ODP	115/230, 1 phase	1 1/4 x 1	47	48	47
4891	1	ODP	230/460, 3 phase	1 1/4 x 1	45	46	45
489A	1 1/2	TEFC	115/230, 1 phase	1 1/4 x 1	55	58	55
489B	1 1/2	TEFC	230/460, 3 phase	1 1/4 x 1	53	56	53
4902	1 1/2	ODP	115/230, 1 phase	1 1/2 x 1 1/4	57	64	57
4903	1 1/2	ODP	230/460, 3 phase	1 1/2 x 1 1/4	54	58	54
490C	2	TEFC	115/230, 1 phase	1 1/2 x 1 1/4	65	72	62
490D	2	TEFC	230/460, 3 phase	1 1/2 x 1 1/4	60	67	63
4904	2	ODP	115/230, 1 phase	1 1/2 x 1 1/4	63	62	63
4905	2	ODP	230/460, 3 phase	1 1/2 x 1 1/4	58	62	58
4900	3	ODP	230, 1 phase	1 1/2 x 1 1/4	69	73	69
490A	3	TEFC	230, 1 phase	1 1/2 x 1 1/4	74	76	71
4901	3	ODP	230/460, 3 phase	1 1/2 x 1 1/4	64	68	69
490B	3	TEFC	230/460, 3 phase	1 1/2 x 1 1/4	66	73	69

NOTE: Driver data is subject to change without notice, see label on driver for actual specifications.

(ODP) Open Drip Proof

(TEFC) Totally Enclosed Fan Cooled

(*) Standard NPT (female) pipe thread.

Performance

Model	GPM of Water at Total Head in Feet									Max Head**
	10'	20'	30'	40'	50'	70'	90'	110'	130'	
4893, 4894, 489C, 489D	42	39	36	32	28	14	-	-	-	81ft.
4895, 4896	52	49	46	42	38	27	12	-	-	98
4890, 4891, 489A, 489B	58	56	52	48	44	34	23	3	-	112
4902, 4903, 490C, 490D	94	90	85	78	71	54	31	-	-	110
4904, 4905, 490A, 490B	107	103	98	92	87	73	55	32	3	131
4900, 4901	118	114	109	104	98	84	69	50	26	148

(**) Shut-off; to convert to psi, divide by 2.31.

Models 489 & 490 Series

Maintenance (Continued)

3. Use a box and/or socket wrench to remove impeller fastener. Remove impeller seal and impeller (Ref. No. 8).

NOTE: Motor shaft must be held in place to remove impeller. Back of the motor either has slot in shaft (use large screwdriver to hold) or has 2 flats on motor shaft (use 7/16 open end wrench to hold). Impeller and impeller fastener unscrew CCW when looking at the front of pump.

IMPORTANT: Care should be taken to insure that the same number and thickness of shim washers (Ref. No. 7) are replaced behind the impeller as was removed. Shim washers are located directly behind impeller and become loose as impeller is removed.

4. The seal head can now be pulled from shaft.
5. Pry seal seat from adapter.

INSTALLATION OF NEW SEAL

CAUTION *The precision lapped faces on mechanical seal are easily damaged. Handle your repair seal carefully. Do not touch polished seal faces.*

IMPORTANT: Be sure that shaft shoulder does not damage polished face (see figure 2).

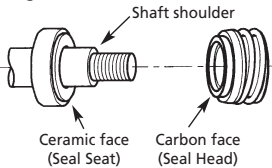

Figure 2

1. Thoroughly clean all surfaces of seal seat cavity in adapter.
2. Using a clean cloth, wipe shaft and shaft sleeve and make certain that they are perfectly clean.
3. Wet the rubber portion of new seal seat with a light coating of soapy water. While wearing clean gloves or using a clean light rag, press seal seat squarely into adapter recess. Use cardboard washer (usually supplied with new seal), place over polished surface and use a piece of pipe or dowel rod to press in firmly but gently. Avoid scratching polished face.
4. Dispose of cardboard washer. Check again to see that polished face is free of dirt and all other foreign particles and that it has not been scratched or damaged.
5. Wet the inside rubber portion of new seal head with a light coating of soapy water. Slide head onto motor shaft with sealing surface facing seal seat (see figure 2).

NOTE: A short "run-in" period may be necessary to provide completely leak-free operation.

6. Screw impeller onto shaft. Use screwdriver slot at rear of motor shaft (opposite the threaded end) to tighten impeller.

NOTE: It may be necessary to remove plug in motor end cap to expose slot. If removed, be sure to reinstall plug AFTER pump is completely assembled.

7. Check if shaft turns freely by spinning impeller. If rubbing or binding is found, remove impeller and add a shim to shaft, then recheck. Repeat

procedure until all rubbing is eliminated.

8. Slide impeller seal onto exposed shaft. Screw acorn nut onto shaft and tighten.
9. Place casing seal on adapter mounting flange. Attach casing using bolts being careful not to pinch or "shave" casing seal. As casing is being tightened, periodically spin impeller to check for interference with casing.

CAUTION *Seal will produce minor drag when spinning motor shaft, but rubbing anywhere else must be eliminated! Otherwise, damage to pump and/or motor may occur.*

For Repair Parts, contact dealer where pump was purchased.

Please provide following information:

- Model number
- Serial number (if any)
- Part description and number as shown in parts list

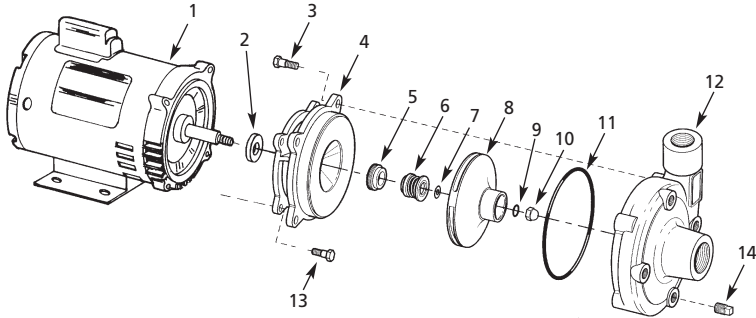

Figure 3 – Repair Parts Illustration

Repair Parts List

Ref. No.	Description	Part Number for Models:							Qty.
		4893 (1/2HP)	4895 (3/4HP)	4890 (1HP)	4902 (1 1/2HP)	4904 (2HP)	4900 (3HP)	4901 (3HP)	
1	Motor	-1 Phase ODP	1626-009-00	1626-010-00	1626-011-00	1626-012-00	1626-024-00	1626-026-00	1
		-3 Phase ODP	1626-013-00	1626-014-00	1626-015-00	1626-016-00	1626-025-00	1626-027-00	
		-1 Phase TEFC	1626-051-00	—	1626-050-00	1626-070-00	1626-071-00	—	
		-3 Phase TEFC	1626-052-00	—	1626-053-00	1626-054-00	1626-072-00	—	
2	Slinger washer	12-117-B	12-117-B	12-117-B	12-117-B	12-117-B	12-117-B	1	
3	Fastener	*	*	*	*	*	*	4	
4	Adapter	-Cast iron	4890-030-09	4890-030-09	4890-030-09	4900-030-09	4900-030-09	4900-030-09	1
		-Bronze	4890-032-09	4890-032-09	4890-032-09	4900-032-09	4900-032-09	4900-032-09	
		-Stainless steel	4890-031-09	4890-031-09	4890-031-09	4900-031-09	4900-031-09	4900-031-09	
5&6†	Shaft seal assembly -Buna N	1640-161-96	1640-161-96	1640-161-96	1640-161-96	1640-161-96	1640-161-96	1	
	-Viton	1640-161-97	1640-161-97	1640-161-97	1640-161-97	1640-161-97	1640-161-97		
7	Impeller shim set (0.005", 0.020", 0.030"; one each)	1806-044-90	1806-044-90	1806-044-90	1806-044-90	1806-044-90	1806-044-90	1	
8	Impeller	4894-011-09	4896-011-09	4891-011-09	4903-011-09	4905-011-09	4901-011-09	1	
9	Impeller seal -Buna N	2105-036-00	2105-036-00	2105-036-00	2105-036-00	2105-036-00	2105-036-00	1	
	-Viton	2105-037-00	2105-037-00	2105-037-00	2105-037-00	2105-037-00	2105-037-00		
10	Impeller fastener	1784-001-00	1784-001-00	1784-001-00	1784-001-00	1784-001-00	1784-001-00	1	
11	Casing seal -Buna N	2221-009-00	2221-009-00	2221-009-00	2119-007-00	2119-007-00	2119-007-00	1	
	-Viton	2221-010-00	2221-010-00	2221-010-00	2119-013-00	2119-013-00	2119-013-00		
12	Casing	-Cast iron	4890-001-09	4890-001-09	4890-001-09	4900-001-09	4900-001-09	4900-001-09	1
		-Bronze	4890-003-09	4890-003-09	4890-003-09	4900-003-09	4900-003-09	4900-003-09	
		-Stainless steel	4890-002-09	4890-002-09	4890-002-09	4900-002-09	4900-002-09	4900-002-09	
13	Fastener	*	*	*	*	*	*	4	
14	3/8" NPT pipe plug	*	*	*	*	*	*	4	

(*) Standard hardware item, available locally.

(†) Seal head and seat available as set only.